

























ELENCO PRODOTTI / PRODUCTS LIST



















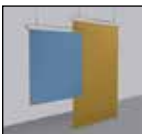







SNOWSOUND

Caimi
B R E V E T T I

SNOWSOUND DIVISION

INDICE / INDEX

	NEW Minimal 59/44	page 8		Baffle Oversize	page 48		Pli Oversize	page 72
	Corner 59/44	page 18		Oversize Wall	page 50		NEW Pli Over	page 74
	Snowfront	page 26		NEW Oversize Ceiling	page 52		Pli	page 76
	Snowdesk	page 28		NEW Oversize Lux	page 56		Baffle 59/44	page 78
	Mitesco Desk	page 32		NEW Giotto Wall	page 64		NEW Tra Light	page 82
	Pli Desk	page 38		NEW Giotto Ceiling	page 66		Tra	page 86
	Oversize Desk	page 40		NEW Giotto Lux	page 68		Mitesco	page 90
	Snowfix	page 42		NEW TL / TL Lux	page 70		Mitesco Totem	page 104

	Mitesco Divider	page 106		V-Flap	page 144		NEW Obelisco	page 166
	NEW Botanica Botanica Totem	page 116		In	page 146		Snowsofa	page 168
	NEW Botanica Wall Botanica Ceiling	page 118		Blade	page 148		NEW Clasp	page 172
	NEW Flat	page 126		Snowsound Art design Gillo Dorfles	page 150		NEW Clasp Divider	page 174
	NEW Flat Totem	page 127		NEW Snowsound Art design by Gio Ponti	page 154		NEW Sepà Sepà Rolls	page 178
	Flap / Maxiflap	page 128		NEW Snowsound Art design Sezgin Aksu	page 158		NEW Pinna	page 180
	Flap Totem	page 134		Corista	page 162		Diesis Bemolle	page 182
	Flap Ceiling	page 136		Cocker	page 163		Si Sboccia Si Sboccia Ceiling	page 186
	Flap Chain	page 140		Snowall	page 164		Fiber Textiles	page 188

Snowsound: 35 awards

I Le innovazioni tecnologiche di Snowsound ed il design dei prodotti realizzati con queste particolari tecnologie hanno ottenuto importanti riconoscimenti a livello internazionale. Tra gli altri riconoscimenti, Snowsound ha ricevuto negli Stati Uniti il premio “International CES Innovations Design and Engineering Awards” considerato il più importante riconoscimento al mondo per l’innovazione nel campo dell’elettronica e dell’Audio/Video, il premio Compasso d’Oro e il premio DesignEuropa Awards, assegnato dall’Ufficio dell’Unione Europea per la proprietà intellettuale (EUIPO).

EN The technological innovations of Snowsound and the design of products made with these special technologies have achieved major world recognitions. Among other honors, in the United States Snowsound was awarded the “International CES Innovations Design and Engineering Awards” considered the most prestigious award for innovation in the field of electronics and audio/video, the Compasso d’Oro award and the DesignEuropa Awards by EUIPO (European Union Intellectual Property Office).

F Les innovations technologiques de Snowsound et le design des produits réalisés avec ces technologies particulières, ont obtenu d’importants reconpenses au niveau international. Parmi les autres, Snowsound a remporté aux Etats-Unis le prix “International CES Innovations Design and Engineering Awards” considéré comme le plus important prix au monde pour l’innovation dans le domaine de l’électronique et de l’audio/vidéo, le prix Compasso d’Oro ADI et le prix DesignEuropa Awards, attribué par l’Office de l’Union Européenne pour la Propriété Intellectuelle (EUIPO).

D Die technologischen Innovationen von Snowsound sowie das Design der mit Hilfe dieser besonderen Technologien erstellten Produkte wurden mit international wichtigen Auszeichnungen prämiert. Unter anderem erhielt Snowsound den Preis “International CES Innovations Design and Engeneering Awards” in U. S. A., weltweit als die wichtigste Auszeichnung im Bereich Elektronik und Audio/Video angesehen, sowie den Preis “Compasso d’oro” und den Preis “DesignEuropa Awards”, der vom Amt der Europäischen Union für Geistiges Eigentum (EUIPO) verliehen wird.

E Las innovaciones tecnológicas de Snowsound y el diseño de los productos realizados con estas tecnologías específicas fueron premiados en el ámbito internacional. Entre otros reconocimientos en Estados Unidos, a Snowsound se le otorgó el premio “International CES Innovations Design and Engineering Awards” que se considera la distinción para la innovación más importante en el mundo para el sector de la electrónica y del Audio/Video. El premio Compasso d’Oro y el premio DesignEuropa Awards de EUIPO European Union Intellectual Property Office).

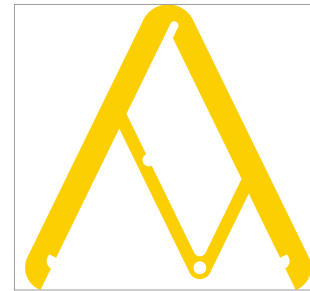

XXIV Compasso d’Oro
(Italy)



DesignEuropa Awards
by EUIPO (European
Union Intellectual
Property Office)



International CES
Innovations Design
and Engineering Awards
(U.S.A.)



Best of NeoCon
Product: Flat
(U.S.A.)



ADI Design Index 2018
Product: Snowsafa
(Italy)



German Design Award
Product: Si Sboccia
(Germany)



German Design Award
Product: Snowsound
Fiber (Germany)



Product Innovation
Grand Prize
Product: Botanica
(U.S.A.)

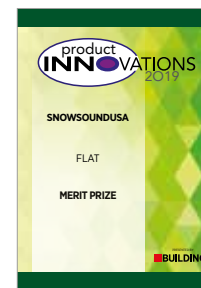

Product Innovation
Merit Prize
Product: Flat (U.S.A.)



Best of NeoCon
(U.S.A.)



German Design Award
(Germany)



Trophée de l'Innovation Bureaux Expo (France)



Gran Design Etico International Award 2018 (Italy)



German Design Award (Germany)



Product Design Awards (Dubai, U.A.E.)



Gran Design Etico International Award (Italy)



Design Journal Best of 2015 (U.S.A.)



German Design Award Product: Baffle (Germany)



German Design Award Product: President (Germany)



German Design Award Product: Analysis software (Germany)



Ho.Re.Ca Innovazione dell'anno (Italy)



Gran Design Etico International Award (Italy)



German Design Award (Germany)



HiP Interior Design Product: Sipario (U.S.A.)



Product Innovation Merit Award (U.S.A.)



Best of NeoCon Product: Diesis (U.S.A.)



HiP Interior Design Product: Blade (U.S.A.)



Best of NeoCon (U.S.A.)



Best of NeoCon (U.S.A.)



ADI Design Index 2014 Product: Flap (Italy)



Trophée de l'Innovation Workspace Expo (France)



Best of NeoCon Product: Analysis software (U.S.A.)



Gran Design Etico International Award (Italy)



German Design Award Product: Diesis (Germany)



Product Innovation Grand Prize Product: Snowsound Fiber (U.S.A.)

SNOWSOUND

COLORI PANNELLI - PANELS' COLORS - COULEURS PANNEAUX -
COLORES PANELES - PANEELEFARBEN

0001

0012

8002

7013

6071



Bianco - White - Blanc - Blanco - Weiss

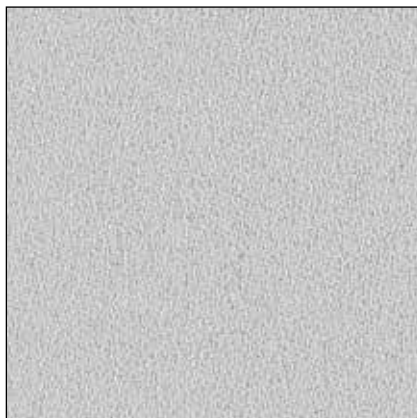

Bianco ghiaccio - Cool white - Blanc glacier
Blanco hielo - Polarweiß

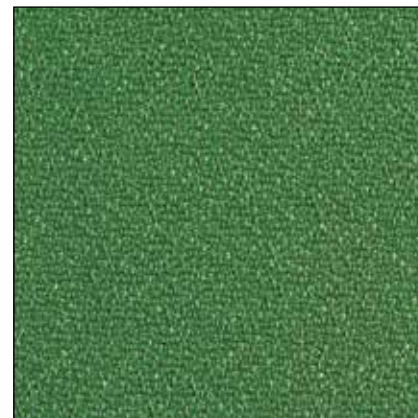

Verde Mela - Apple green - Vert Pomme
Verde Manzana - Grüner Apfel

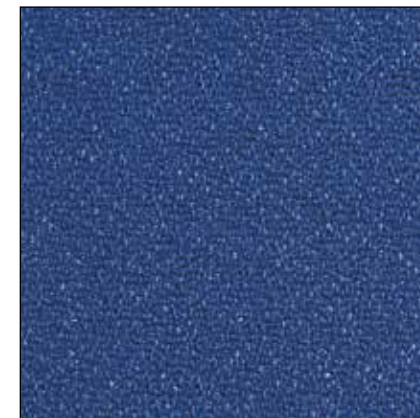

Blu - Blue - Bleu - Azul - Blau

8004

8007

4027

8033



Grigio argento - Silver grey - Gris argenté
Gris plata - Silbergrau



Grigio scuro - Dark grey - Gris foncé -
Gris oscuro Dunkelgrau



Rosso - Red - Rouge - Rojo - Rot



Nero - Black - Noir - Negro -Schwarz

Vi invitiamo a verificare nel listino prezzi i colori disponibili per ogni singolo prodotto - We kindly invite you to check in the price list the colors available for each product - Nous vous invitons à vérifier dans la liste de prix les couleurs disponibles pour chaque produit - Le invitamos a consultar en la lista de precios los colores disponibles para cada producto - Wir laden Sie ein, in der Preisliste die verfügbaren Farben für jedes Produkt zu überprüfen.

SNOWSOUND

COLORI PANNELLI - PANELS' COLORS - COULEURS PANNEAUX -
COLORES PANELES - PANEELEFARBEN

6075

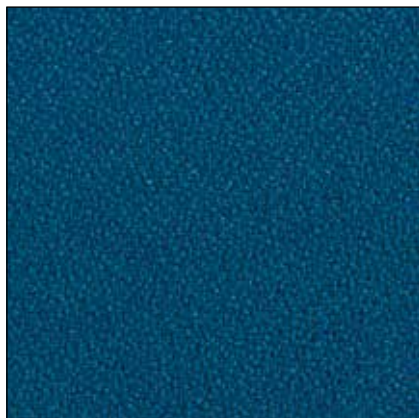

Ottanio - Teal - Sarcelle -
Verde azulado - Petrol

6046



Azzurro - Light blue - Bleu clair -
Azul claro - Hellblau

7004



Verde chiaro - Light green - Vert clair -
Verde chiaro - Hellgrün

4086



Mattone - Brick red - Rouge brique -
Rojo teja - Ziegelrot

3008



Giallo Sole - Sun yellow - Jaune Soleil
Amarillo Sol - Gelbe Sonne

4030



Arancione Carota - Carrot orange
Orange Carotte - Anaranjado Zanahoria
Orange Karotte

2005

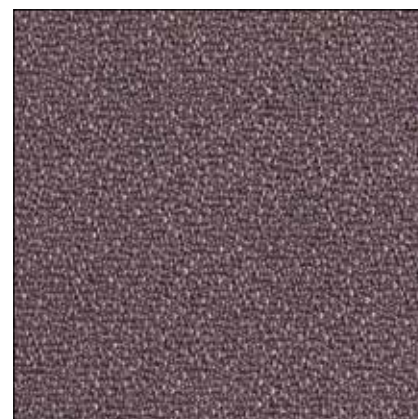

Tortora - Dove-grey - Taupe
Tórtola - Taubengrau

1008



Beige - Beige - Beige - Beige - Beige

Vi invitiamo a verificare nel listino prezzi i colori disponibili per ogni singolo prodotto - We kindly invite you to check in the price list the colors available for each product - Nous vous invitons à vérifier dans la liste de prix les couleurs disponibles pour chaque produit - Le invitamos a consultar en la lista de precios los colores disponibles para cada producto - Wir laden Sie ein, in der Preisliste die verfügbaren Farben für jedes Produkt zu überprüfen.

PER APPLICAZIONI A SCRIVANIA - DESK MOUNTING - MONTAGE SUR LE BUREAU
MONTAJE SOBRE MESAS DE ESCRITORIO - TISCHBEFESTIGUNG

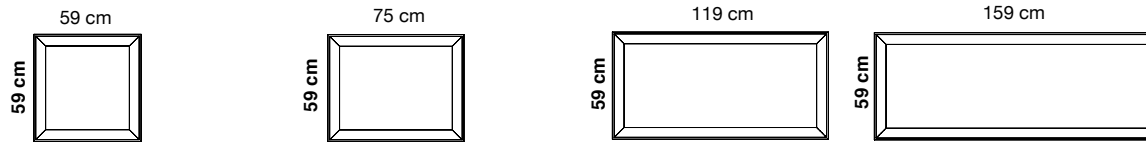

Colore Colour	Codice/Code Prezzo/Price	Codice/Code Prezzo/Price	Codice/Code Prezzo/Price	Codice/Code Prezzo/Price	
Bianco White Blanc	0001	7S066-0001	7S086-0001	7S126-0001	7S166-0001
Grigio argento Silver grey Gris argenté	8004	7S066-8004	7S086-8004	7S126-8004	7S166-8004
Grigio scuro Dark grey Gris foncé	8007	7S066-8007	7S086-8007	7S126-8007	7S166-8007
Beige Beige Beige	1008	7S066-1008	7S086-1008	7S126-1008	7S166-1008
Tortora Dove-grey Taupe	2005	7S066-2005	7S086-2005	7S126-2005	7S166-2005
Giallo Yellow Jaune	3008	7S066-3008	7S086-3008	7S126-3008	7S166-3008
Arancione Orange Orange	4030	7S066-4030	7S086-4030	7S126-4030	7S166-4030
Rosso Red Rouge	4027	7S066-4027	7S086-4027	7S126-4027	7S166-4027
Verde chiaro Light green Vert clair	7004	7S066-7004	7S086-7004	7S126-7004	7S166-7004
Mattone Brick red Rouge brique	4086	7S066-4086	7S086-4086	7S126-4086	7S166-4086
Azzurro Light blue Bleu clair	6046	7S066-6046	7S086-6046	7S126-6046	7S166-6046
Ottanio Teal Sarcelle	6075	7S066-6075	7S086-6075	7S126-6075	7S166-6075

Pannello con imbottitura interna in poliester a **densità variabile** Snowsound® Technology. Rivestimento esterno in tessuto di poliester Trevira CS®.

Panel with polyester internal padding with Snowsound® Technology **variable density**. Polyester covering in Trevira CS® fabric.

Panneau avec rembourrage interne en polyester à **densité variable** Snowsound® Technology. Revêtement externe en tissu de polyester Trevira CS®.

Panel con acolchado interior de poliéster de **densidad variable** Snowsound® Technology. Revestimiento exterior de tejido de poliéster Trevira CS®.

Panel mit Polyester-Füllmaterial von **unterschiedlicher Dichte** Snowsound® Technology. Polyester-Bezug aus Trevira CS®-Material.

PER APPLICAZIONI A SCRIVANIA - DESK MOUNTING - MONTAGE SUR LE BUREAU
MONTAJE SOBRE MESAS DE ESCRITORIO - TISCHBEFESTIGUNG

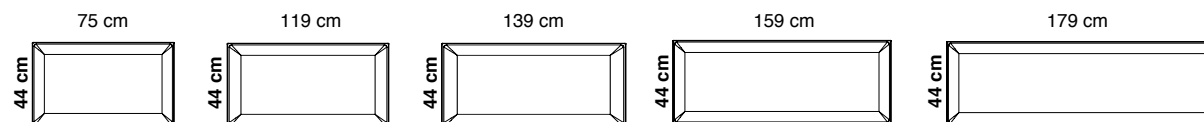

Colore Colour	Codice/Code Prezzo/Price	Codice/Code Prezzo/Price	Codice/Code Prezzo/Price	Codice/Code Prezzo/Price	Codice/Code Prezzo/Price	
Bianco White Blanc	0001	7S408-0001	7S412-0001	7S414-0001	7S416-0001	7S418-0001
Grigio argento Silver grey Gris argenté	8004	7S408-8004	7S412-8004	7S414-8004	7S416-8004	7S418-8004
Grigio scuro Dark grey Gris foncé	8007	7S408-8007	7S412-8007	7S414-8007	7S416-8007	7S418-8007
Beige Beige Beige	1008	7S408-1008	7S412-1008	7S414-1008	7S416-1008	7S418-1008
Tortora Dove-grey Taupe	2005	7S408-2005	7S412-2005	7S414-2005	7S416-2005	7S418-2005
Giallo Yellow Jaune	3008	7S408-3008	7S412-3008	7S414-3008	7S416-3008	7S418-3008
Arancione Orange Orange	4030	7S408-4030	7S412-4030	7S414-4030	7S416-4030	7S418-4030
Rosso Red Rouge	4027	7S408-4027	7S412-4027	7S414-4027	7S416-4027	7S418-4027
Verde chiaro Light green Vert clair	7004	7S408-7004	7S412-7004	7S414-7004	7S416-7004	7S418-7004
Mattone Brick red Rouge brique	4086	7S408-4086	7S412-4086	7S414-4086	7S416-4086	7S418-4086
Azzurro Light blue Bleu clair	6046	7S408-6046	7S412-6046	7S414-6046	7S416-6046	7S418-6046
Ottanio Teal Sarcelle	6075	7S408-6075	7S412-6075	7S414-6075	7S416-6075	7S418-6075

Pannello con imbottitura interna in poliester a **densità variabile** Snowsound® Technology. Rivestimento esterno in tessuto di poliester Trevira CS®.

Panel with polyester internal padding with Snowsound® Technology **variable density**. Polyester covering in Trevira CS® fabric.

Panneau avec rembourrage interne en polyester à **densité variable** Snowsound® Technology. Revêtement externe en tissu de polyester Trevira CS®.

Panel con acolchado interior de poliéster de **densidad variable** Snowsound® Technology. Revestimiento exterior de tejido de poliéster Trevira CS®.

Panel mit Polyester-Füllmaterial von **unterschiedlicher Dichte** Snowsound® Technology. Polyester-Bezug aus Trevira CS®-Material.

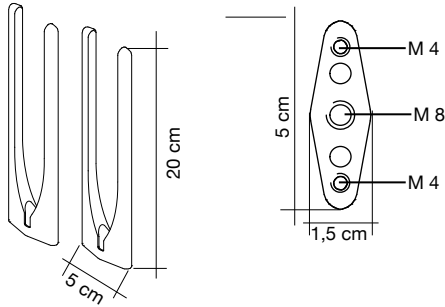
**7SMF20-GA**

Grigio argento
Silver grey
Gris argenté
Gris plata
Silbergrau

1 coppia / 1 pair
1 paire / 1 pare
1 Paar

Coppia attacchi in zama verniciata con polveri epossidiche per fissaggio sopra il piano della scrivania tramite viti (non incluse). **Per pannelli Minimal 59 pag. 8 e Minimal 44 pag. 9.**

Pair of brackets in powder-coated zamac to be fixed on the desk top with screws (not included). **For panels: Minimal 59 page 8 and Minimal 44 page 9.**

Paire d'étriers en zamac peint époxy pour fixation sur le bureau par vis (non incluses). **Pour panneaux Minimal 59 page 8 et Minimal 44 page 9.**

Par de abrazaderas de zamac recubierto epoxi para fijación sobre el plano del escritorio por medio de tornillos (no incluidos). **Para paneles Minimal 59 pag. 8 y Minimal 44 pag 9.**

1 Paar Halterungen aus pulverbeschichtetem Zamac zur Befestigung auf der Tischplatte durch Schrauben (nicht inkludiert). **Für Paneele: Minimal 59 Seite 8 und Minimal 44 Seite 9.**

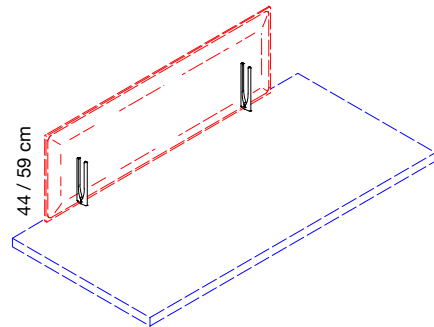
**7SMF20-BO**

Bianco opaco
Mat white
Blanc mat
Blanco mate
Mattweiß

1 coppia / 1 pair
1 paire / 1 pare
1 Paar

7SMF20-N

Nero opaco
Mat black
Noir mat
Negro mate
Mattschwarz

1 coppia / 1 pair
1 paire / 1 pare
1 Paar

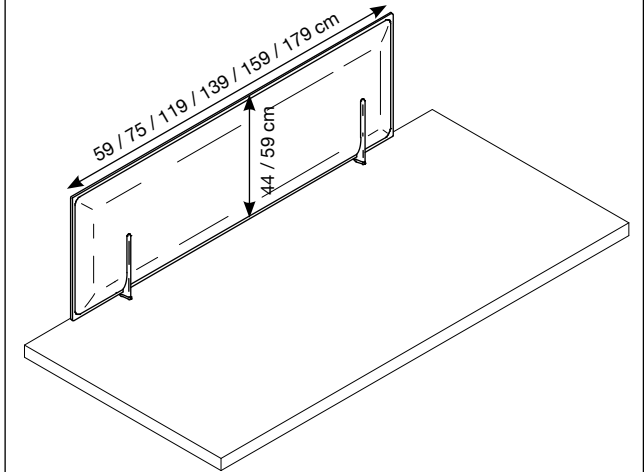

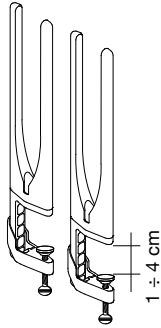

7SMFM20-GA

Grigio argento
Silver grey
Gris argenté
Gris plata
Silbergrau

1 coppia / 1 pair
1 paire / 1 pare
1 Paar

Coppia attacchi in zama con morsetto in zama verniciati con polveri epossidiche per fissaggio al piano della scrivania. **Per pannelli Minimal 59 pag. 8 e Minimal 44 pag. 9.**

Pair of brackets with clamp in powder-coated zamac for connection to the desk top. **For panels: Minimal 59 page 8 and Minimal 44 page 9.**

Paire d'étriers en zamac avec étai en zamac peint époxy pour fixation au bureau. **Pour panneaux Minimal 59 page 8 et Minimal 44 page 9.**

Par de abrazaderas de zamac con mordaza recubiertas epoxi para fijacion al plano del escritorio. **Para paneles Minimal 59 pag 8 y Minimal 44 page 9.**

1 Paar Halterungen aus pulverbeschichtetem Zamac mit Klemmen zur Befestigung an der Tischplatte. **Für Paneele: Minimal 59 Seite 8 und Minimal 44 Seite 9.**

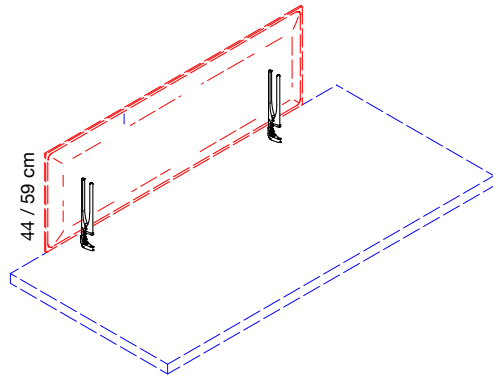

7SMFM20-BO

Bianco opaco
Mat white
Blanc mat
Blanco mate
Mattweiß

1 coppia / 1 pair
1 paire / 1 pare
1 Paar

7SMFM20-N

Nero opaco
Mat black
Noir mat
Negro mate
Mattschwarz

1 coppia / 1 pair
1 paire / 1 pare
1 Paar

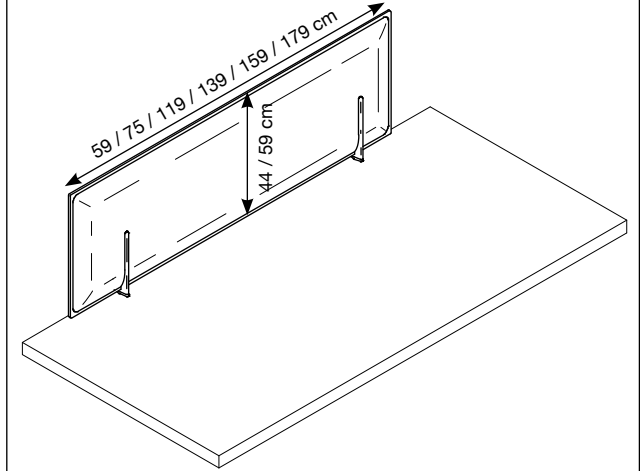

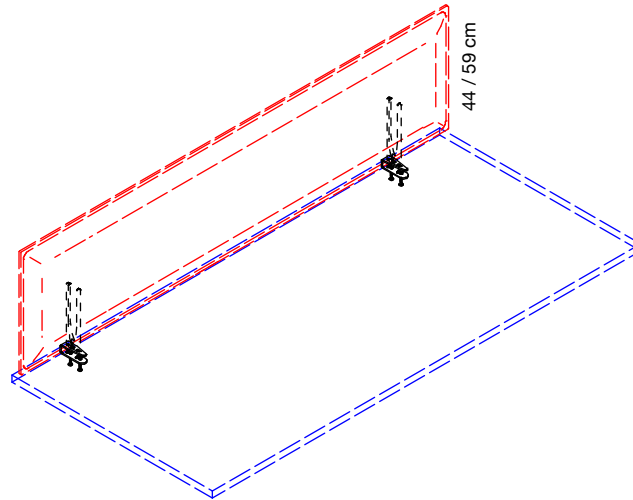
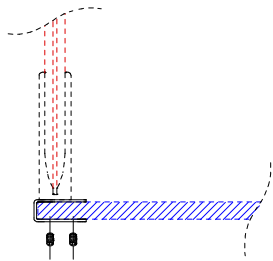
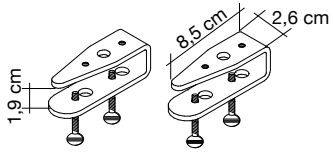
**7SMP19-GA**

Grigio argento
Silver grey
Gris argenté
Gris plata
Silbergrau

1 coppia / 1 pair
1 paire / 1 pare
1 Paar

7SMP19-BO

Bianco opaco
Mat white
Blanc mat
Blanco mate
Mattweiß

1 coppia / 1 pair
1 paire / 1 pare
1 Paar

Coppia supporti in acciaio verniciato da utilizzare con attacchi 7SMF20-GA / 7SMF20-BO / 7SMF20-N.

Pair of supports for powder-coated steel brackets to be used with 7SMF20-GA / 7SMF20-BO / 7SMF20-N.

Paire de supports peint époxy à utiliser avec étriers 7SMF20-GA / 7SMF20-BO / 7SMF20-N.

2 soportes para fijaciones de acero barnizado. Utilización con abrazaderas 7SMF20-GA / 7SMF20-BO / 7SMF20-N.

1 Paar Stahlbefestigungen zur Verwendung mit den Halterungen 7SMF20-GA / 7SMF20-BO / 7SMF20-N.

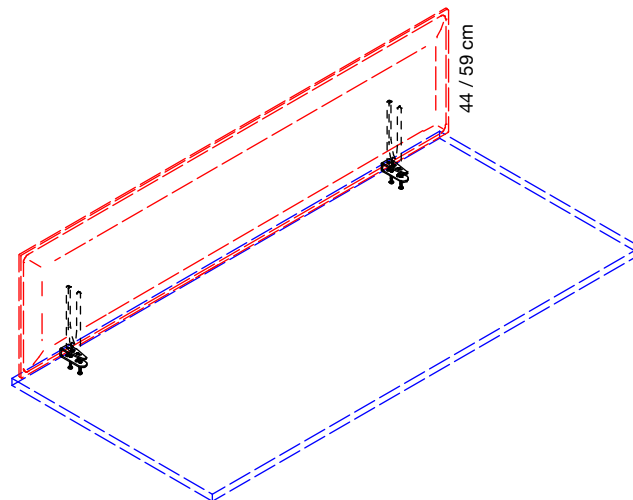
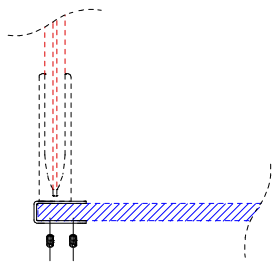
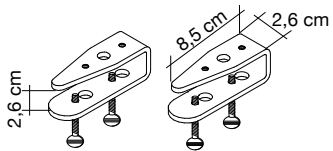
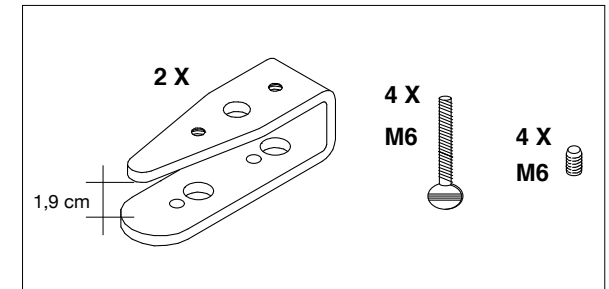
**7SMP26-GA**

Grigio argento
Silver grey
Gris argenté
Gris plata
Silbergrau

1 coppia / 1 pair
1 paire / 1 pare
1 Paar

7SMP26-BO

Bianco opaco
Mat white
Blanc mat
Blanco mate
Mattweiß

1 coppia / 1 pair
1 paire / 1 pare
1 Paar

Coppia supporti in acciaio verniciato da utilizzare con attacchi 7SMF20-GA / 7SMF20-BO / 7SMF20-N.

Pair of supports for powder-coated steel brackets to be used with 7SMF20-GA / 7SMF20-BO / 7SMF20-N.

Paire de supports peint époxy à utiliser avec étriers 7SMF20-GA / 7SMF20-BO / 7SMF20-N.

2 soportes para fijaciones de acero barnizado. Utilización con abrazaderas 7SMF20-GA / 7SMF20-BO / 7SMF20-N.

1 Paar Stahlbefestigungen zur Verwendung mit den Halterungen 7SMF20-GA / 7SMF20-BO / 7SMF20-N.

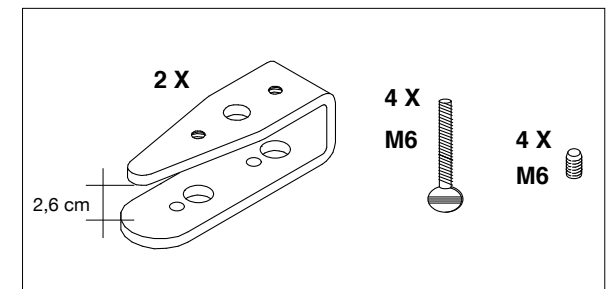

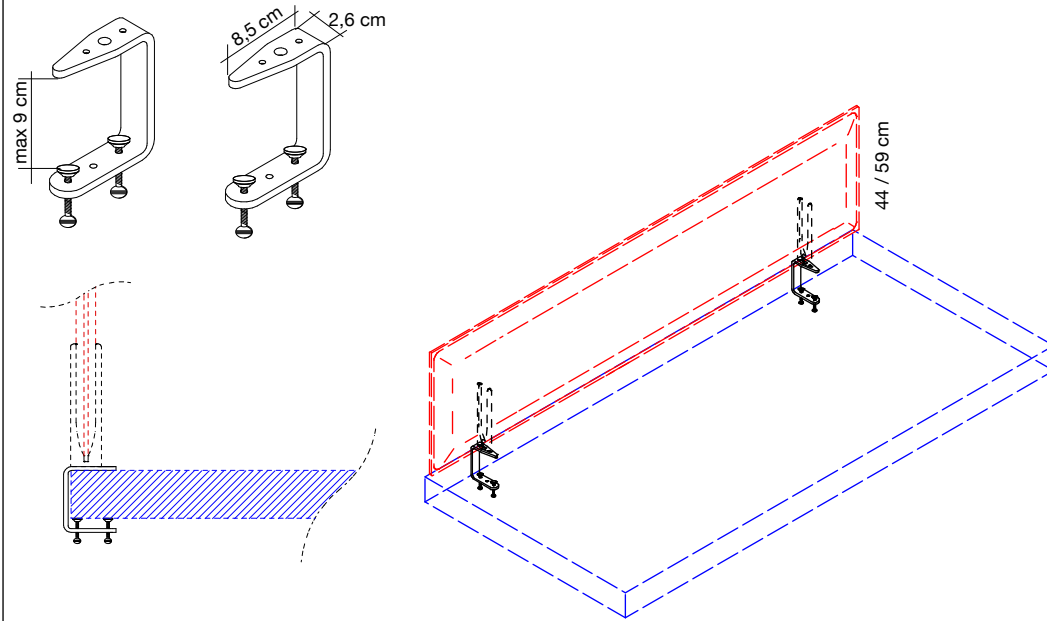

7SMP95-GA

Grigio argento
Silver grey
Gris argenté
Gris plata
Silbergrau

1 coppia / 1 pair
1 paire / 1 pare
1 Paar

Coppia supporti in acciaio verniciato da utilizzare con attacchi 7SMF20-GA / 7SMF20-BO / 7SMF20-N.

Pair of supports for powder-coated steel brackets to be used with 7SMF20-GA / 7SMF20-BO / 7SMF20-N.

Paire de supports peint époxy à utiliser avec étriers 7SMF20-GA / 7SMF20-BO / 7SMF20-N.

2 soportes para fijaciones de acero barnizado. Utilización con abrazaderas 7SMF20-GA / 7SMF20-BO / 7SMF20-N.

1 Paar Stahlbefestigungen zur Verwendung mit den Halterungen 7SMF20-GA / 7SMF20-BO / 7SMF20-N.

7SMP95-BO

Bianco opaco
Mat white
Blanc mat
Blanco mate
Mattweiß

1 coppia / 1 pair
1 paire / 1 pare
1 Paar

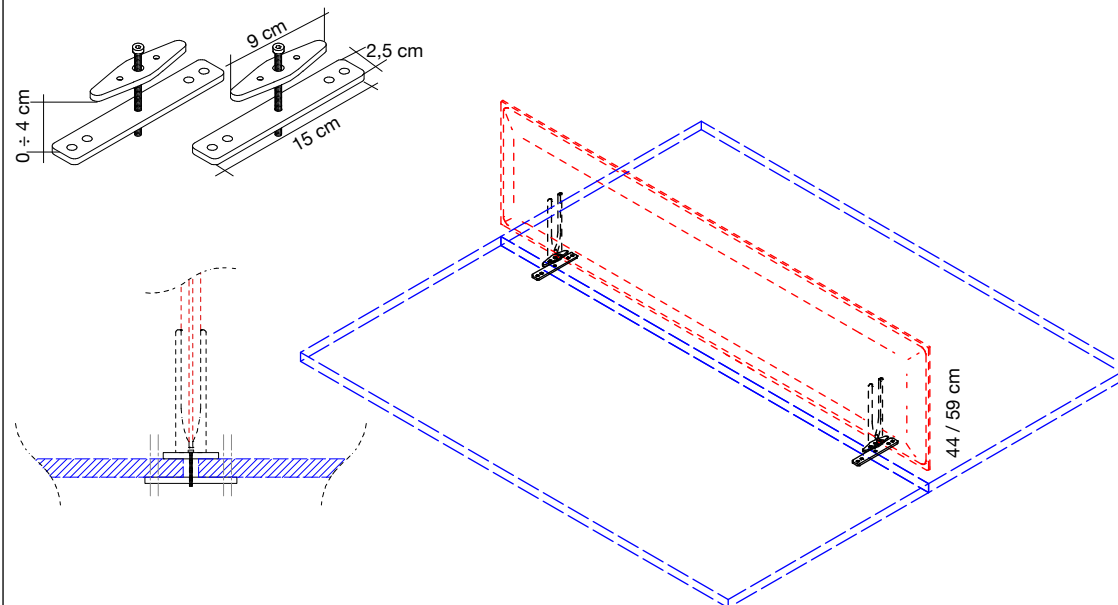

7SMP2-GA

Grigio argento
Silver grey
Gris argenté
Gris plata
Silbergrau

1 coppia / 1 pair
1 paire / 1 pare
1 Paar

Coppia supporti in acciaio verniciato da utilizzare con attacchi 7SMF20-GA / 7SMF20-BO / 7SMF20-N. Per fissaggio da sopra il piano della scrivania, con vite centrale.

Pair of supports for powder-coated steel brackets to be used with 7SMF20-GA / 7SMF20-BO / 7SMF20-N. For attachment from above the desktop, using a central screw.

Paire de supports peint époxy à utiliser avec étriers 7SMF20-GA / 7SMF20-BO / 7SMF20-N. Fixation par le dessus du plan de travail, avec vis centrale.

2 soportes para fijaciones de acero barnizado. Utilización con abrazaderas 7SMF20-GA / 7SMF20-BO / 7SMF20-N. Para fijación desde arriba del tablero de la mesa, con tornillo central.

1 Paar Stahlbefestigungen zur Verwendung mit den Halterungen 7SMF20-GA / 7SMF20-BO / 7SMF20-N. Zur Befestigung von oben auf der Tischplatte, mit zentraler Schraube.

7SMP2-BO

Bianco opaco
Mat white
Blanc mat
Blanco mate
Mattweiß

1 coppia / 1 pair
1 paire / 1 pare
1 Paar

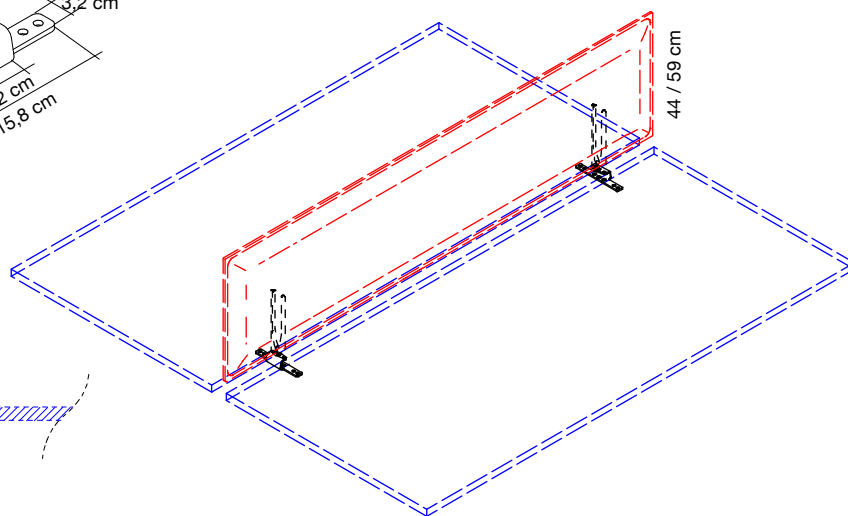
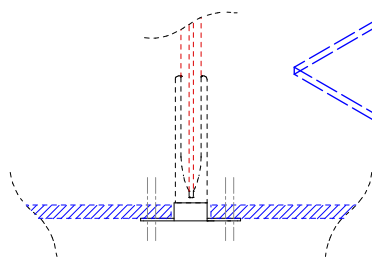
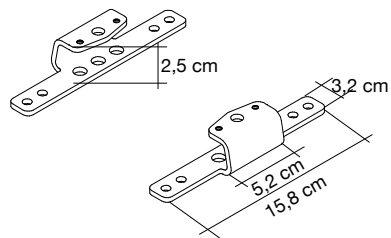
**7SMPL-GA**

Grigio argento
Silver grey
Gris argenté
Gris plata
Silbergrau

1 coppia / 1 pair
1 paire / 1 pare
1 Paar

Coppia supporti in acciaio verniciato da utilizzare con attacchi 7SMF20-GA / 7SMF20-BO / 7SMF20-N.

Pair of supports for powder-coated steel brackets to be used with 7SMF20-GA / 7SMF20-BO / 7SMF20-N.

Paire de supports peint époxy à utiliser avec étriers 7SMF20-GA / 7SMF20-BO / 7SMF20-N.

2 soportes para fijaciones de acero barnizado. Utilización con abrazaderas 7SMF20-GA / 7SMF20-BO / 7SMF20-N.

1 Paar Stahlbefestigungen zur Verwendung mit den Halterungen 7SMF20-GA / 7SMF20-BO / 7SMF20-N.

7SMPL-BO

Bianco opaco
Mat white
Blanc mat
Blanco mate
Mattweiß

1 coppia / 1 pair
1 paire / 1 pare
1 Paar

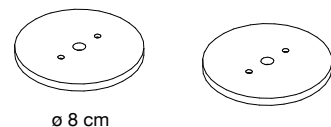

ø 8 cm

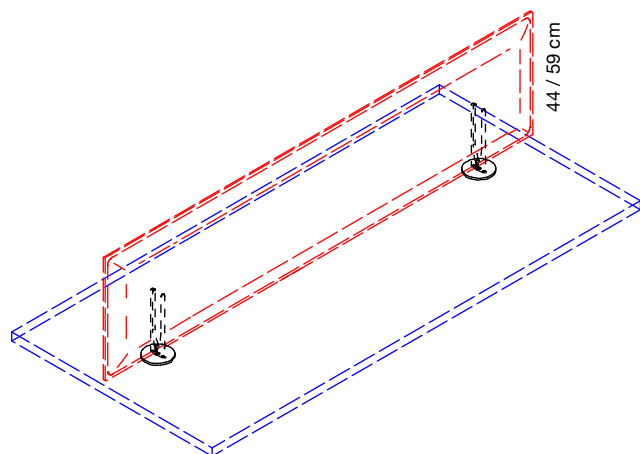
**7SMPM-GA**

Grigio argento
Silver grey
Gris argenté
Gris plata
Silbergrau

1 coppia / 1 pair
1 paire / 1 pare
1 Paar

Coppia di basi in acciaio verniciato per fissaggio al piano della scrivania. Fissaggio al piano obbligatorio a cura del cliente. Scegliere il tipo di fissaggio / incollaggio idoneo alla superficie del piano. Da utilizzare con attacchi 7SMF20-GA / 7SMF20-BO / 7SMF20-N.

Pair of bases in powder coated steel for fixing to the desk top. Mandatory fastening to the top at customer's care. Choose the most suitable connection/gluing for the surface. To be used with 7SMF20-GA / 7SMF20-BO / 7SMF20-N.

Paire de bases en acier peint en époxy à fixer au dessus du bureau. Fixation au dessus obligatoire de la part du client. Choisir le type d'accrochage/collage adapté à la surface du dessus. A utiliser avec étriers 7SMF20-GA / 7SMF20-BO / 7SMF20-N.

7SMPM-BO

Bianco opaco
Mat white
Blanc mat
Blanco mate
Mattweiß

1 coppia / 1 pair
1 paire / 1 pare
1 Paar

Par de bases de acero para fijacion al plan del escritorio. Enganche al plano obligatorio por parte del cliente. Elegir el tipo de sujetador / enlace lo mas adecuado para la superficie del plano. Utilización con abrazaderas 7SMF20-GA / 7SMF20-BO / 7SMF20-N.

1 Paar Stahlböden aus pulverbeschichtetem Stahl zur Befestigung auf der Tischplatte. Befestigung durch den Kunden unbedingt erforderlich. Wählen Sie die am besten geeignete Art der Verbindung/Verklebung für die betreffende Oberfläche. Zur Verwendung mit den Halterungen 7SMF20-GA / 7SMF20-BO / 7SMF20-N.

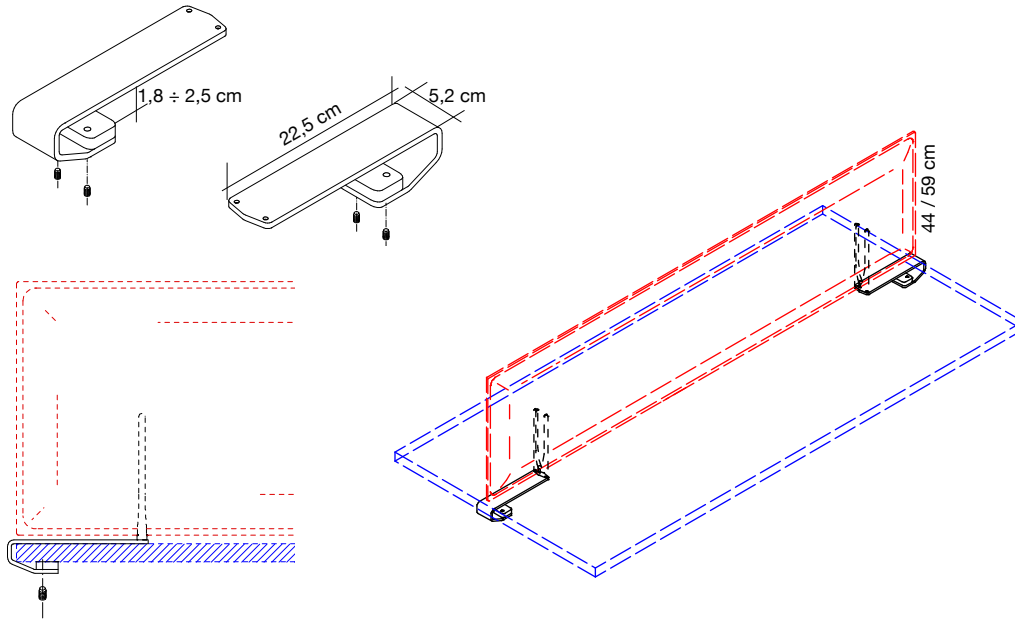

7SMPC1-GA

Grigio argento
Silver grey
Gris argenté
Gris plata
Silbergrau

1 coppia / 1 pair
1 paire / 1 pare
1 Paar

Coppia supporti in acciaio verniciato da utilizzare con attacchi 7SMF20-GA / 7SMF20-BO / 7SMF20-N.

Pair of supports for powder-coated steel brackets to be used with 7SMF20-GA / 7SMF20-BO / 7SMF20-N.

Paire de supports peint époxy à utiliser avec étriers 7SMF20-GA / 7SMF20-BO / 7SMF20-N.

2 soportes para fijaciones de acero barnizado. Utilización con abrazaderas 7SMF20-GA / 7SMF20-BO / 7SMF20-N.

1 Paar Stahlbefestigungen zur Verwendung mit den Halterungen 7SMF20-GA / 7SMF20-BO / 7SMF20-N.

7SMPC1-BO

Bianco opaco
Mat white
Blanc mat
Blanco mate
Mattweiß

1 coppia / 1 pair
1 paire / 1 pare
1 Paar

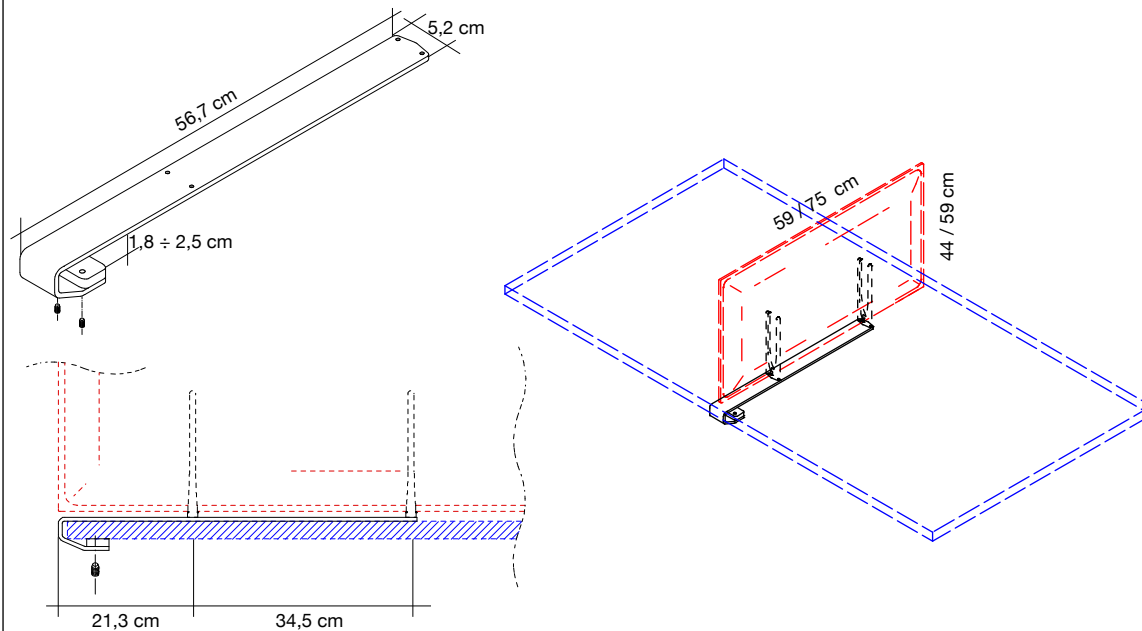

7SMPC2-GA

Grigio argento
Silver grey
Gris argenté
Gris plata
Silbergrau

Supporto in acciaio verniciato da utilizzare con attacchi 7SMF20-GA / 7SMF20-BO / 7SMF20-N.

Support for powder-coated steel brackets to be used with 7SMF20-GA / 7SMF20-BO / 7SMF20-N.

Support peint époxy à utiliser avec étriers 7SMF20-GA / 7SMF20-BO / 7SMF20-N.

Soporte para fijaciones de acero barnizado. Utilización con abrazaderas 7SMF20-GA / 7SMF20-BO / 7SMF20-N.

Stahlbefestigungen zur Verwendung mit den Halterungen 7SMF20-GA / 7SMF20-BO / 7SMF20-N.

7SMPC2-BO

Bianco opaco
Mat white
Blanc mat
Blanco mate
Mattweiß



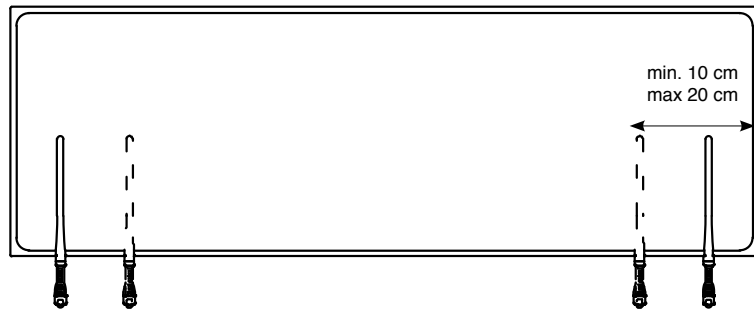

Gli attacchi vengono fissati a scrivania e il pannello viene inserito negli attacchi.

Brackets are fixed to the desktop and the panel is inserted into the brackets.

Les supports sont fixée sur le plan de travail et le panneau est inséré dans les supports.

Las conexiones se fijan al escritorio y el panel se inserta en las conexiones.

Die Halterungen werden an der Tischplatte befestigt und das Paneel wird in die Halterungen eingesetzt.



PER APPLICAZIONI A SCRIVANIA - DESK MOUNTING - MONTAGE SUR LE BUREAU
MONTAJE SOBRE MESAS DE ESCRITORIO - TISCHBEFESTIGUNG

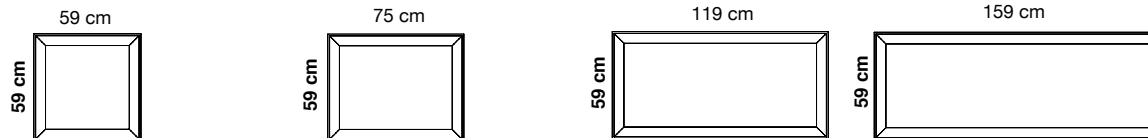

Colore Colour	Codice/Code Prezzo/Price	Codice/Code Prezzo/Price	Codice/Code Prezzo/Price	Codice/Code Prezzo/Price	
Bianco White Blanc	0001	7B0606-0001	7B0806-0001	7B1206-0001	7B1606-0001
Grigio argento Silver grey Gris argenté	8004	7B0606-8004	7B0806-8004	7B1206-8004	7B1606-8004
Grigio scuro Dark grey Gris foncé	8007	7B0606-8007	7B0806-8007	7B1206-8007	7B1606-8007
Beige Beige Beige	1008	7B0606-1008	7B0806-1008	7B1206-1008	7B1606-1008
Tortora Dove-grey Taupe	2005	7B0606-2005	7B0806-2005	7B1206-2005	7B1606-2005
Giallo Yellow Jaune	3008	7B0606-3008	7B0806-3008	7B1206-3008	7B1606-3008
Arancione Orange Orange	4030	7B0606-4030	7B0806-4030	7B1206-4030	7B1606-4030
Rosso Red Rouge	4027	7B0606-4027	7B0806-4027	7B1206-4027	7B1606-4027
Verde chiaro Light green Vert clair	7004	7B0606-7004	7B0806-7004	7B1206-7004	7B1606-7004
Mattone Brick red Rouge brique	4086	7B0606-4086	7B0806-4086	7B1206-4086	7B1606-4086
Azzurro Light blue Bleu clair	6046	7B0606-6046	7B0806-6046	7B1206-6046	7B1606-6046
Ottanio Teal Sarcelle	6075	7B0606-6075	7B0806-6075	7B1206-6075	7B1606-6075

Pannello con imbottitura interna in poliester a **densità variabile** Snowsound® Technology. Rivestimento esterno in tessuto di poliester Trevira CS®.

Panel with polyester internal padding with Snowsound® Technology **variable density**. Polyester covering in Trevira CS® fabric.

Panneau avec rembourrage interne en polyester à **densité variable** Snowsound® Technology. Revêtement externe en tissu de polyester Trevira CS®.

Panel con acolchado interior de poliéster de **densidad variable** Snowsound® Technology. Revestimiento exterior de tejido de poliéster Trevira CS®.

Panel mit Polyester-Füllmaterial von **unterschiedlicher Dichte** Snowsound® Technology. Polyester-Bezug aus Trevira CS®-Material.

PER APPLICAZIONI A SCRIVANIA - DESK MOUNTING - MONTAGE SUR LE BUREAU
MONTAJE SOBRE MESAS DE ESCRITORIO - TISCHBEFESTIGUNG

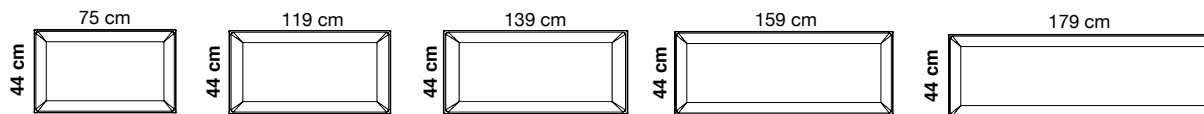

Colore Colour	Codice/Code Prezzo/Price	Codice/Code Prezzo/Price	Codice/Code Prezzo/Price	Codice/Code Prezzo/Price	Codice/Code Prezzo/Price	
Bianco White Blanc	0001	7B0408-0001	7B0412-0001	7B0414-0001	7B0416-0001	7B0418-0001
Grigio argento Silver grey Gris argenté	8004	7B0408-8004	7B0412-8004	7B0414-8004	7B0416-8004	7B0418-8004
Grigio scuro Dark grey Gris foncé	8007	7B0408-8007	7B0412-8007	7B0414-8007	7B0416-8007	7B0418-8007
Beige Beige Beige	1008	7B0408-1008	7B0412-1008	7B0414-1008	7B0416-1008	7B0418-1008
Tortora Dove-grey Taupe	2005	7B0408-2005	7B0412-2005	7B0414-2005	7B0416-2005	7B0418-2005
Giallo Yellow Jaune	3008	7B0408-3008	7B0412-3008	7B0414-3008	7B0416-3008	7B0418-3008
Arancione Orange Orange	4030	7B0408-4030	7B0412-4030	7B0414-4030	7B0416-4030	7B0418-4030
Rosso Red Rouge	4027	7B0408-4027	7B0412-4027	7B0414-4027	7B0416-4027	7B0418-4027
Verde chiaro Light green Vert clair	7004	7B0408-7004	7B0412-7004	7B0414-7004	7B0416-7004	7B0418-7004
Mattone Brick red Rouge brique	4086	7B0408-4086	7B0412-4086	7B0414-4086	7B0416-4086	7B0418-4086
Azzurro Light blue Bleu clair	6046	7B0408-6046	7B0412-6046	7B0414-6046	7B0416-6046	7B0418-6046
Ottanio Teal Sarcelle	6075	7B0408-6075	7B0412-6075	7B0414-6075	7B0416-6075	7B0418-6075

Pannello con imbottitura interna in poliester a **densità variabile** Snowsound® Technology. Rivestimento esterno in tessuto di poliester Trevira CS®.

Panel with polyester internal padding with Snowsound® Technology **variable density**. Polyester covering in Trevira CS® fabric.

Panneau avec rembourrage interne en polyester à **densité variable** Snowsound® Technology. Revêtement externe en tissu de polyester Trevira CS®.

Panel con acolchado interior de poliéster de **densidad variable** Snowsound® Technology. Revestimiento exterior de tejido de poliéster Trevira CS®.

Panel mit Polyester-Füllmaterial von **unterschiedlicher Dichte** Snowsound® Technology. Polyester-Bezug aus Trevira CS®-Material.

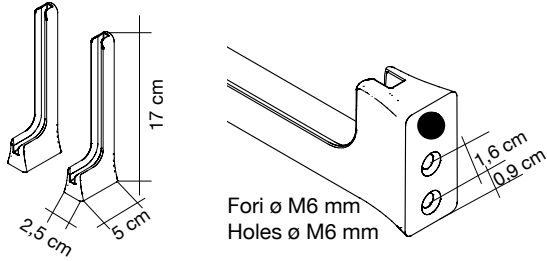
**7B400-GA**

Grigio argento
Silver grey
Gris argenté
Gris plata
Silbergrau

1 coppia / 1 pair
1 paire / 1 pare
1 Paar

Coppia attacchi in zama verniciata con polveri eposidiche per fissaggio da sotto il piano della scrivania tramite viti (non incluse). **Per pannelli Corner 59 pag. 18 e Corner 44 pag. 19.**

Pair of brackets in powder-coated zamac to be fixed under the desk top with screws (not included). **For panels: Corner 59 page 18 and Corner 44 page 19.**

Paire d'étriers en zamac peint époxy pour fixation par le dessous du bureau par des vis (pas incluses). **Pour panneaux Corner 59 page 18 et Corner 44 page 19.**

Par de abrazaderas de zamac recubierto epoxi para fijación debajo del plan del escritorio por medio de tornillos (no incluidos). **Para panels Corner 59 pag. 18 y Corner 44 pag 19.**

1 Paar Halterungen aus pulverbeschichtetem Zamac zur Befestigung unter der Tischplatte durch Schrauben (nicht inkludiert). **Für Paneele: Corner 59 Seite 18 und Corner 44 Seite 19.**

7B400-BO

Bianco opaco
Mat white
Blanc mat
Blanco mate
Mattweiß

1 coppia / 1 pair
1 paire / 1 pare
1 Paar

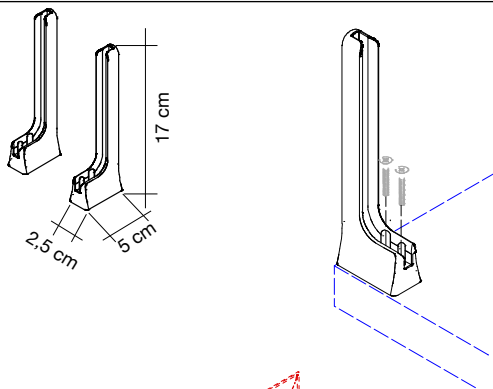
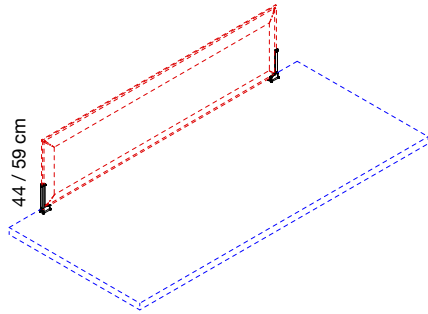
**7B401-GA**

Grigio argento
Silver grey
Gris argenté
Gris plata
Silbergrau

1 coppia / 1 pair
1 paire / 1 pare
1 Paar

Coppia attacchi in zama verniciata con polveri eposidiche per fissaggio sopra il piano della scrivania tramite viti (non incluse). **Per pannelli Corner 59 pag. 18 e Corner 44 pag. 19.**

Pair of brackets in powder-coated zamac to be fixed on the desk top with screws (not included). **For panels: Corner 59 page 18 and Corner 44 page 19.**

Paire d'étriers en zamac peint époxy pour fixation sur le bureau par des vis (pas incluses). **Pour panneaux Corner 59 page 18 et Corner 44 page 19.**

Par de abrazaderas de zamac recubierto epoxi para fijación sobre el plan del escritorio por medio de tornillos (no incluidos). **Para panels Corner 59 pag. 18 y Corner 44 pag 19.**

1 Paar Halterungen aus pulverbeschichtetem Zamac zur Befestigung auf der Tischplatte durch Schrauben (nicht inkludiert). **Für Paneele: Corner 59 Seite 18 und Corner 44 Seite 19.**

7B401-BO

Bianco opaco
Mat white
Blanc mat
Blanco mate
Mattweiß

1 coppia / 1 pair
1 paire / 1 pare
1 Paar

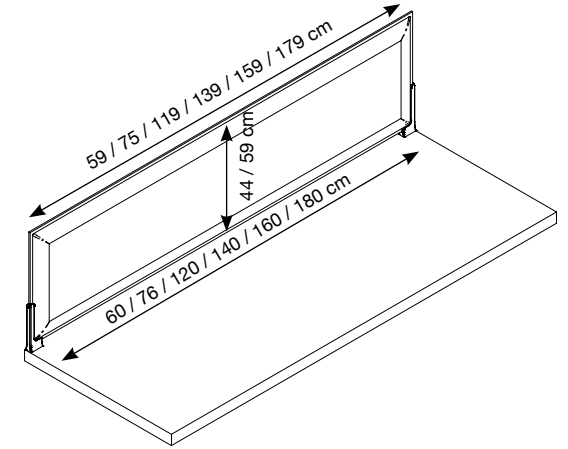
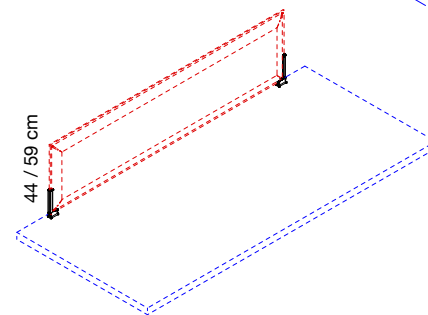

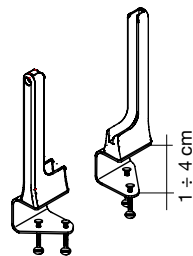

7B4100-GA

Grigio argento
Silver grey
Gris argenté
Gris plata
Silbergrau

1 coppia /1 pair
1 paire / 1 pare
1 Paar

Coppia attacchi in zama con morsetto in acciaio verniciati con polveri epossidiche per fissaggio al piano della scrivania. **Per pannelli Corner 59 pag. 18 e Corner 44 pag. 19.**

Pair of brackets with clamp in powder-coated steel and zamac for connection to the desk top. **For panels: Corner 59 page 18 and Corner 44 page 19.**

Paire d'étriers en zamac avec étai en acier peint époxy pour fixation au bureau. **Pour panneaux Corner 59 page 18 et Corner 44 page 19.**

7B4100-BO

Bianco opaco
Mat white
Blanc mat
Blanco mate
Mattweiß

1 coppia /1 pair
1 paire / 1 pare
1 Paar

Par de abrazaderas de zamac con sujetador de acero recubiertos epoxi para fijacion al plan del escritorio. **Para paneles Corner 59 pag 18 y Corner 44 page 19.**

1 Paar Halterungen aus pulverbeschichtetem Stahl und Zamac mit Klemmen zur Befestigung an der Tischplatte. **Für Paneele: Corner 59 Seite 18 und Corner 44 Seite 19.**

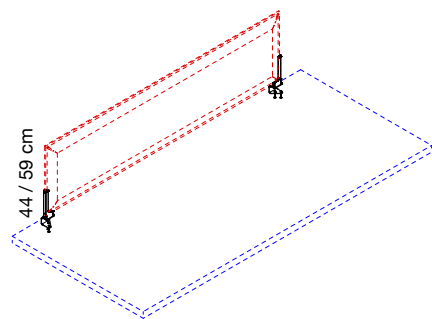

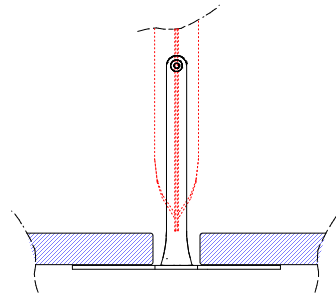
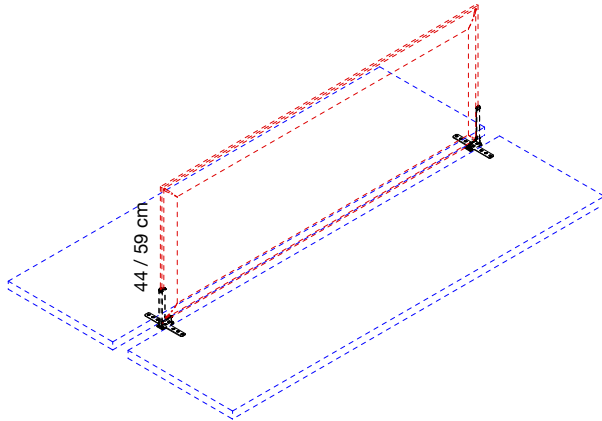
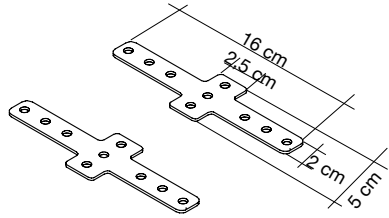
**7B414-GA**

Grigio argento
Silver grey
Gris argenté
Gris plata
Silbergrau

1 coppia / 1 pair
1 paire / 1 pare
1 Paar

Coppia supporti in acciaio da utilizzare con attacchi 7B400-GA / 7B400-BO.

2 steel supports for brackets 7B400-GA / 7B400-BO.

Paire de supports à utiliser avec étriers 7B400-GA / 7B400-BO.

2 Soportes para fijaciones de acero. Utilizacion con abrazaderas 7B400-GA / 7B400-BO.

2 Stahlbefestigungen zur Verwendung mit den Halterungen 7B400-GA / 7B400-BO.

7B414-BO

Bianco opaco
Mat white
Blanc mat
Blanco mate
Mattweiß

1 coppia / 1 pair
1 paire / 1 pare
1 Paar

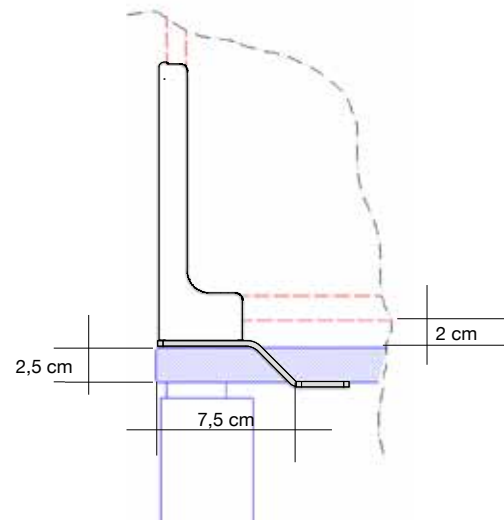
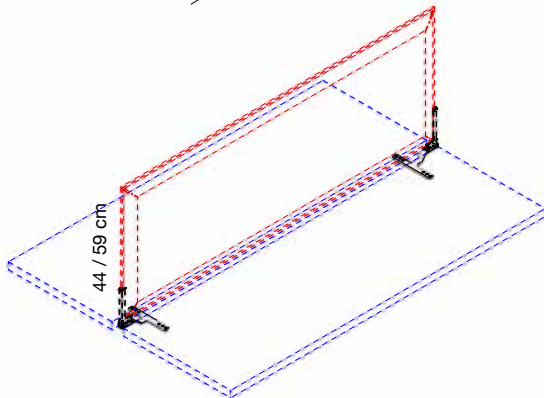
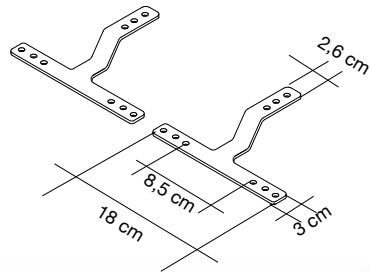
**7B415-GA**

Grigio argento
Silver grey
Gris argenté
Gris plata
Silbergrau

1 coppia / 1 pair
1 paire / 1 pare
1 Paar

Coppia supporti in acciaio da utilizzare con attacchi 7B400-GA / 7B400-BO.

2 steel supports for brackets 7B400-GA / 7B400-BO.

Paire de supports à utiliser avec étriers 7B400-GA / 7B400-BO.

2 soportes para fijaciones de acero. Utilizacion con abrazaderas 7B400-GA / 7B400-BO.

2 Stahlbefestigungen zur Verwendung mit den Halterungen 7B400-GA / 7B400-BO.

7B415-BO

Bianco opaco
Mat white
Blanc mat
Blanco mate
Mattweiß

1 coppia / 1 pair
1 paire / 1 pare
1 Paar

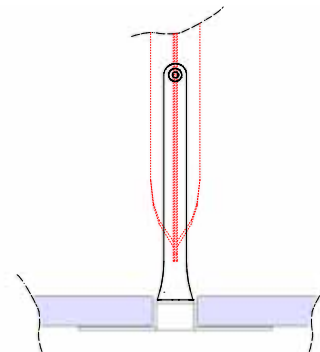

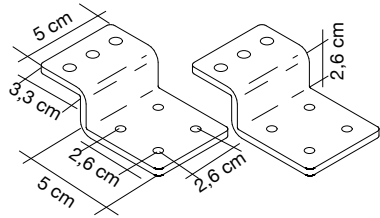

sp. 0,4 cm

7B413/L-GA

Grigio argento
Silver grey
Gris argenté
Gris plata
Silbergrau

1 coppia / 1 pair
1 paire / 1 pare
1 Paar

7B413/L-BO

Bianco opaco
Mat white
Blanc mat
Blanco mate
Mattweiß

1 coppia / 1 pair
1 paire / 1 pare
1 Paar

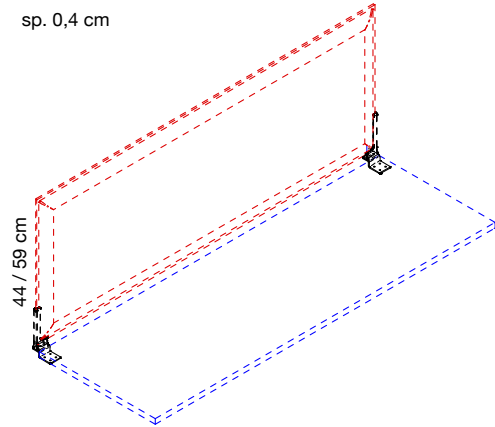

Coppia supporti in acciaio da utilizzare con attacchi 7B400-GA / 7B400-BO.

2 steel supports for brackets 7B400-GA / 7B400-BO.

2 supports à utiliser avec étriers 7B400-GA / 7B400-BO.

2 soportes para fijaciones de acero. Utilizacion con abrazaderas 7B400-GA / 7B400-BO.

2 Stahlbefestigungen zur Verwendung mit den Halterungen 7B400-GA / 7B400-BO.

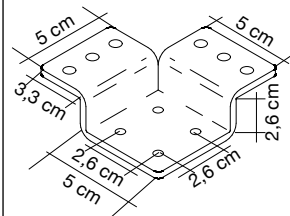
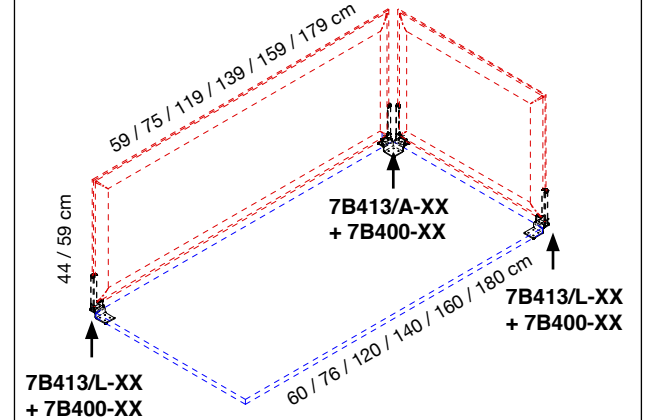

sp. 0,4 cm

7B413/A-GA

Grigio argento
Silver grey
Gris argenté
Gris plata
Silbergrau

7B413/A-BO

Bianco opaco
Mat white
Blanc mat
Blanco mate
Mattweiß

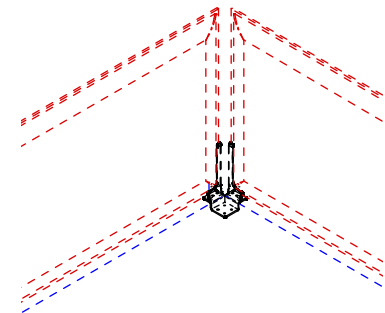

Supporto in acciaio da utilizzare con attacchi 7B400-GA / 7B400-BO.

Steel supports for brackets 7B400-GA / 7B400-BO.

Supports à utiliser avec étriers 7B400-GA / 7B400-BO.

Soportes para fijaciones de acero. Utilizacion con abrazaderas 7B400-GA / 7B400-BO.

Stahlbefestigungen zur Verwendung mit den Halterungen 7B400-GA / 7B400-BO.

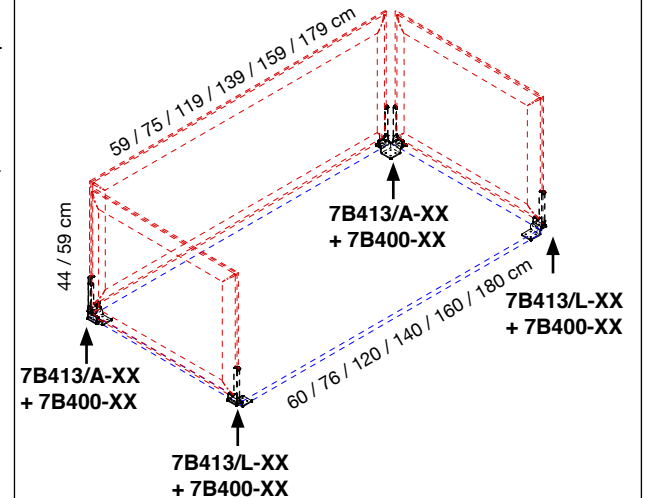

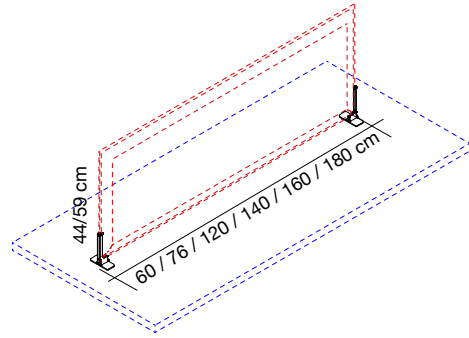
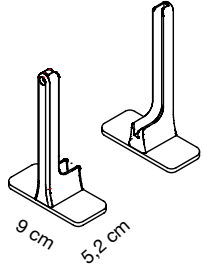
**7B4120-GA**

Grigio argento
Silver grey
Gris argenté
Gris plata
Silbergrau

1 coppia / 1 pair
1 paire / 1 pare
1 Paar

7B4120-BO

Bianco opaco
Mat white
Blanc mat
Blanco mate
Mattweiß

1 coppia / 1 pair
1 paire / 1 pare
1 Paar

Coppia staffe con base in acciaio verniciato con polveri epossidiche per fissaggio al piano della scrivania. Fissaggio al piano obbligatorio a cura del cliente. Scegliere il tipo di fissaggio / incollaggio idoneo alla superficie del piano. **Per pannelli Corner 59 pag. 18 e Corner 44 pag. 19.**

Pair of brackets with base in powder coated steel for fixing to the desk top. Mandatory fastening to the top at customer's care. Choose the most suitable connection/gluing for the surface. **For panels: Corner 59 page 18 and Corner 44 page 19.**

Paire d'étriers avec base en acier peint en époxy à fixer au dessus du bureau. Fixation au dessus obligatoire de la part du client. Choisir le type d'accrochage/collage indiqué pour à la surface du dessus. **Pour panneaux Corner 59 page 18 et Corner 44 page 19.**

Par de abrazaderas con base de acero recubierto epoxi para fijación al plan del escritorio. Enganche al plano obligatorio por parte del cliente. Elegir el tipo de sujetador / enlace lo mas adecuado para la superficie del plano. **Para paneles Corner 59 pag. 18 y Corner 44 pag. 19.**

1 Paar Halterungen mit Standfüßen aus pulverbeschichtetem Stahl zur Befestigung auf der Tischplatte. Befestigung durch den Kunden unbedingt erforderlich. Wählen Sie die am besten geeignete Art der Verbindung/Verklebung für die betreffende Oberfläche. **Für Paneele: Corner 59 Seite 18 und Corner 44 Seite 19.**

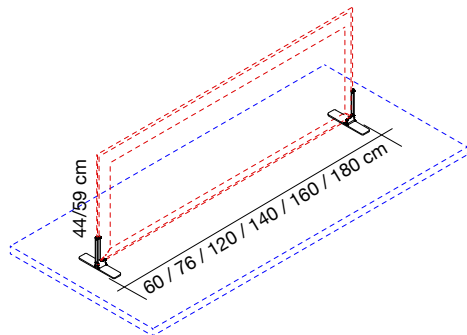
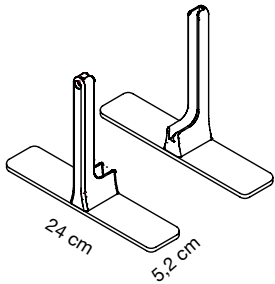
**7B4140-GA**

Grigio argento
Silver grey
Gris argenté
Gris plata
Silbergrau

1 coppia / 1 pair
1 paire / 1 pare
1 Paar

7B4140-BO

Bianco opaco
Mat white
Blanc mat
Blanco mate
Mattweiß

1 coppia / 1 pair
1 paire / 1 pare
1 Paar

Coppia staffe con base in acciaio verniciato con polveri epossidiche per appoggio al piano della scrivania. **Per pannelli Corner 59 pag. 18 e Corner 44 pag. 19.**

Pair of brackets with base in powder coated steel for desk top stand. **For panels: Corner 59 page 18 and Corner 44 page 19.**

Paire d'étriers avec base en acier peint en époxy à poser sur le dessus du bureau. **Pour panneaux Corner 59 page 18 et Corner 44 page 19.**

Par de abrazaderas con base de acero recubierto epoxi para apoyar al escritorio. **Para paneles Corner 59 pag. 18 y Corner 44 pag. 19.**

Paar Halterungen mit Standfüßen aus pulverbeschichtetem Stahl zur Aufstellung auf der Tischplatte. **Für Paneele: Corner 59 Seite 18 und Corner 44 Seite 19.**



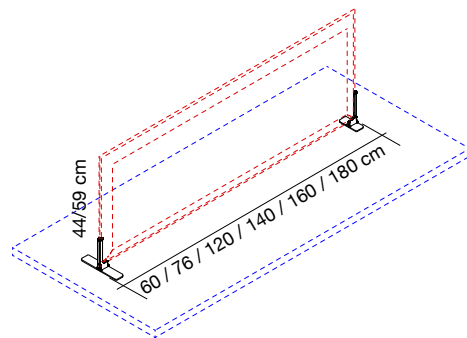
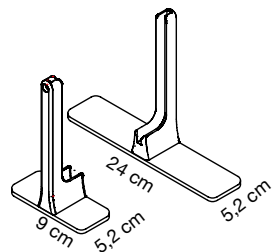

7B4130-GA

Grigio argento
Silver grey
Gris argenté
Gris plata
Silbergrau

1 coppia / 1 pair
1 paire / 1 pare
1 Paar

7B4130-BO

Bianco opaco
Mat white
Blanc mat
Blanco mate
Mattweiß

1 coppia / 1 pair
1 paire / 1 pare
1 Paar

Coppia staffe con base in acciaio verniciato con polveri epossidiche per appoggio al piano della scrivania.
Per pannelli Corner 59 pag. 18 e Corner 44 pag. 19.

Pair of brackets with base in powder coated steel for desk top stand. **For panels: Corner 59 page 18 and Corner 44 page 19.**

Paire d'étriers avec base en acier peint en époxy à poser sur le dessus du bureau.
Pour panneaux Corner 59 page 18 et Corner 44 page 19.

Par de abrazaderas con base de acero recubierto epoxi para apoyar al escritorio.
Para panel Corner 59 pag. 18 y Corner 44 pag. 19.

Paar Halterungen mit Standfüßen aus pulverbeschichtetem Stahl zur Aufstellung auf der Tischplatte.
Für Paneele: Corner 59 Seite 18 und Corner 44 Seite 19.

PER APPLICAZIONI A SCRIVANIA - DESK MOUNTING - MONTAGE SUR LE BUREAU
MONTAJE SOBRE MESAS DE ESCRITORIO - TISCHBEFESTIGUNG

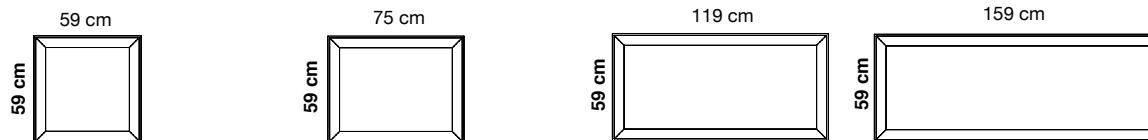

Colore Colour	Codice/Code Prezzo/Price	Codice/Code Prezzo/Price	Codice/Code Prezzo/Price	Codice/Code Prezzo/Price	
Bianco White Blanc	0001	7S066-0001	7S086-0001	7S126-0001	7S166-0001
Grigio argento Silver grey Gris argenté	8004	7S066-8004	7S086-8004	7S126-8004	7S166-8004
Grigio scuro Dark grey Gris foncé	8007	7S066-8007	7S086-8007	7S126-8007	7S166-8007
Beige Beige Beige	1008	7S066-1008	7S086-1008	7S126-1008	7S166-1008
Tortora Dove-grey Taupe	2005	7S066-2005	7S086-2005	7S126-2005	7S166-2005
Giallo Yellow Jaune	3008	7S066-3008	7S086-3008	7S126-3008	7S166-3008
Arancione Orange Orange	4030	7S066-4030	7S086-4030	7S126-4030	7S166-4030
Rosso Red Rouge	4027	7S066-4027	7S086-4027	7S126-4027	7S166-4027
Verde chiaro Light green Vert clair	7004	7S066-7004	7S086-7004	7S126-7004	7S166-7004
Mattone Brick red Rouge brique	4086	7S066-4086	7S086-4086	7S126-4086	7S166-4086
Azzurro Light blue Bleu clair	6046	7S066-6046	7S086-6046	7S126-6046	7S166-6046
Ottanio Teal Sarcelle	6075	7S066-6075	7S086-6075	7S126-6075	7S166-6075

Pannello con imbottitura interna in poliester a **densità variabile** Snowsound® Technology. Rivestimento esterno in tessuto di poliester Trevira CS®.

Panel with polyester internal padding with Snowsound® Technology **variable density**. Polyester covering in Trevira CS® fabric.

Panneau avec rembourrage interne en polyester à **densité variable** Snowsound® Technology. Revêtement externe en tissu de polyester Trevira CS®.

Panel con acolchado interior de poliéster de **densidad variable** Snowsound® Technology. Revestimiento exterior de tejido de poliéster Trevira CS®.

Panel mit Polyester-Füllmaterial von **unterschiedlicher Dichte** Snowsound® Technology. Polyester-Bezug aus Trevira CS®-Material.

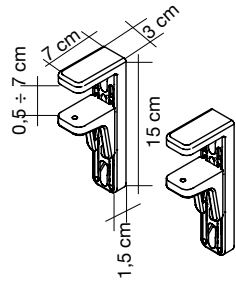

7S310-GA
Grigio argento
Silver grey
Gris argenté
Gris plata
Silbergrau

1 coppia / 1 pair
1 paire / 1 pare
1 Paar

Coppia attacchi con morsetto regolabile in alluminio e acciaio verniciato con polveri epossidiche per fissaggio al piano della scrivania. **Per pannelli Snowfront pag. 26.**

Pair of brackets with adjustable clamp in powder-coated steel and aluminium for connection to the desk top. **For Snowfront panels page 26.**

7S310-BO
Bianco opaco
Mat white
Blanc mat
Blanco mate
Mattweiß

1 coppia / 1 pair
1 paire / 1 pare
1 Paar

Paire d'étriers avec étau réglable en acier et aluminium peint époxy pour fixation au bureau. **Pour panneaux Snowfront page 26.**

Par de abrazaderas con sujetador ajustable en acero y aluminio recubiertos epoxi para fijación al plan del escritorio. **Para panels Snowfront pag. 26.**

1 Paar Halterungen aus pulverbeschichtetem Stahl und Aluminium mit einstellbare Klemmen zur Befestigung an der Tischplatte. **Für Snowfront Paneele, Seite 26.**

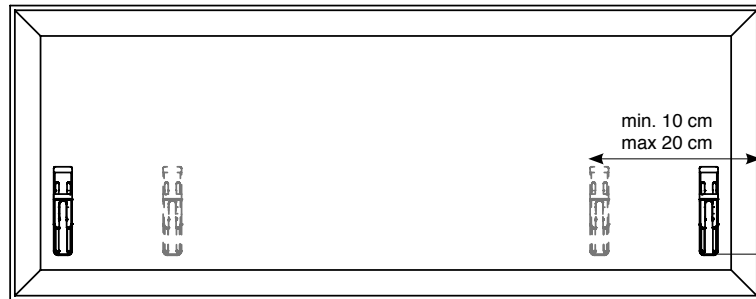
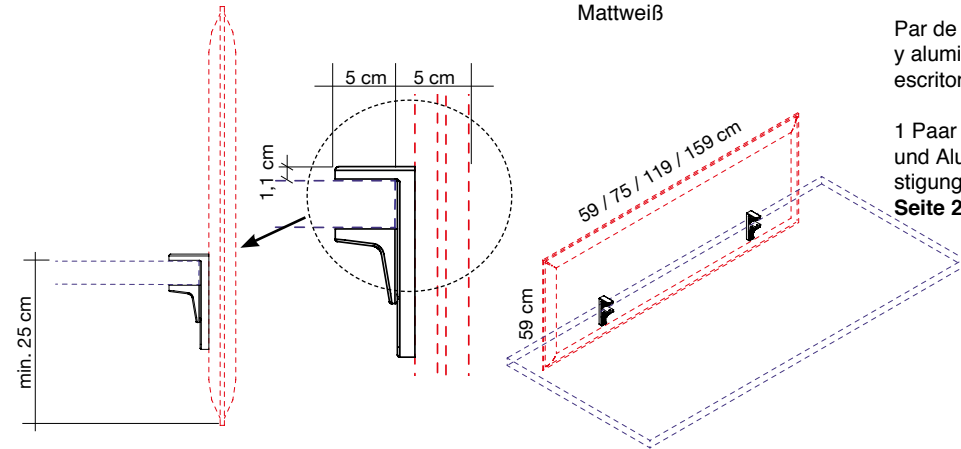

I morsetti possono essere applicati lungo il pannello.

The clamps can be positioned along the panel.

Les étriers peuvent être appliqués le long du panneau.

Los abrazaderas pueden ser posicionados a lo largo del panel.

Die Klemmen können beliebig entlang des Paneels angebracht werden.

min. 10 cm

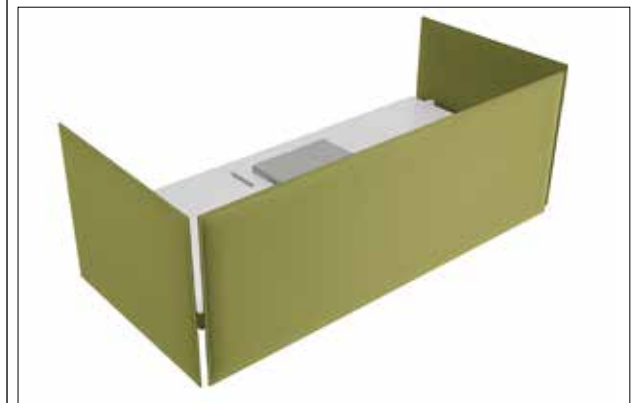
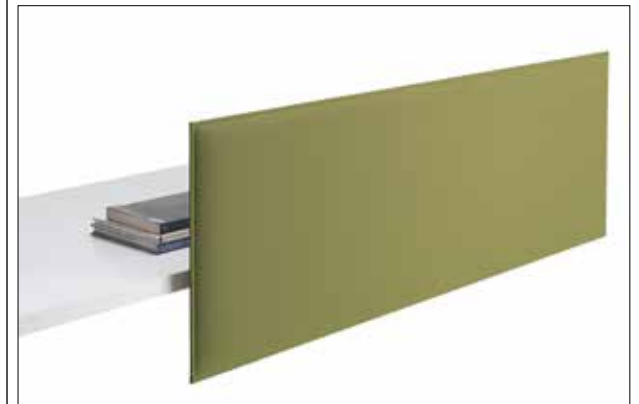

PER APPLICAZIONI A SCRIVANIA - DESK MOUNTING - MONTAGE SUR LE BUREAU
MONTAJE SOBRE MESAS DE ESCRITORIO - TISCHBEFESTIGUNG

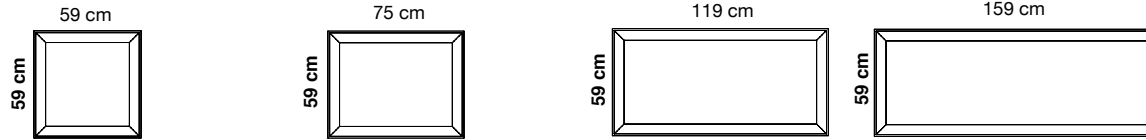

Colore Colour	Codice/Code Prezzo/Price	Codice/Code Prezzo/Price	Codice/Code Prezzo/Price	Codice/Code Prezzo/Price	
Bianco White Blanc	0001	7S066-0001	7S086-0001	7S126-0001	7S166-0001
Grigio argento Silver grey Gris argenté	8004	7S066-8004	7S086-8004	7S126-8004	7S166-8004
Grigio scuro Dark grey Gris foncé	8007	7S066-8007	7S086-8007	7S126-8007	7S166-8007
Beige Beige Beige	1008	7S066-1008	7S086-1008	7S126-1008	7S166-1008
Tortora Dove-grey Taupe	2005	7S066-2005	7S086-2005	7S126-2005	7S166-2005
Giallo Yellow Jaune	3008	7S066-3008	7S086-3008	7S126-3008	7S166-3008
Arancione Orange Orange	4030	7S066-4030	7S086-4030	7S126-4030	7S166-4030
Rosso Red Rouge	4027	7S066-4027	7S086-4027	7S126-4027	7S166-4027
Verde chiaro Light green Vert clair	7004	7S066-7004	7S086-7004	7S126-7004	7S166-7004
Mattone Brick red Rouge brique	4086	7S066-4086	7S086-4086	7S126-4086	7S166-4086
Azzurro Light blue Bleu clair	6046	7S066-6046	7S086-6046	7S126-6046	7S166-6046
Ottanio Teal Sarcelle	6075	7S066-6075	7S086-6075	7S126-6075	7S166-6075

Pannello con imbottitura interna in poliester a **densità variabile** Snowsound® Technology. Rivestimento esterno in tessuto di poliester Trevira CS®.

Panel with polyester internal padding with Snowsound® Technology **variable density**. Polyester covering in Trevira CS® fabric.

Panneau avec rembourrage interne en polyester à **densité variable** Snowsound® Technology. Revêtement externe en tissu de polyester Trevira CS®.

Panel con acolchado interior de poliéster de **densidad variable** Snowsound® Technology. Revestimiento exterior de tejido de poliéster Trevira CS®.

Panel mit Polyester-Füllmaterial von **unterschiedlicher Dichte** Snowsound® Technology. Polyester-Bezug aus Trevira CS®-Material.

1



- 1) Posizionare le staffe cod. 7S511-GA / 7S511-BO / 7S1100-GA / 7S1100-BO
- 1) Position the brackets code 7S511-GA / 7S511-BO / 7S1100-GA / 7S1100-BO
- 1) Positionnez les étriers réf. 7S511-GA / 7S511-BO / 7S1100-GA / 7S1100-BO
- 1) Colocar los soportes cod. 7S511-GA / 7S511-BO / 7S1100-GA / 7S1100-BO
- 1) Positionieren Sie die Halterungen Art. Nr 7S111-GA / 7S111-BO / 7S1100-GA / 7S1100-BO

2 / 3

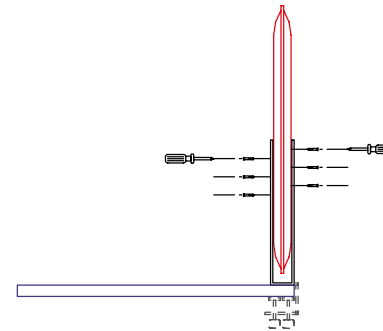

2 e 3) Avvitare le staffe cod 7S511-GA / 7S511-BO / 7S1100-GA / 7S1100-BO direttamente al pannello e applicare la copertura in tecnopolimero.

2 and 3) Directly screw the brackets code 7S511-GA / 7S511-BO / 7S1100-GA / 7S1100-BO to the panels and put on the hi-tech polymer front cover.

2 et 3) Vissez les supports réf. 7S511-GA / 7S511-BO / 7S1100-GA / 7S1100-BO directement au panneau et appliquez les couvertures en technopolymère.

2 y 3) Atornillar los soportes cod. 7S511-GA / 7S511-BO / 7S1100-GA / 7S1100-BO directamente al panel y aplicar las coberturas en tecnopolimero.

2 und 3) Schrauben Sie die Halterungen Art. 7S511-GA / 7S511-BO / 7S1100-GA / 7S1100-BO direkt an das Paneel und befestigen Sie die vordere Abdeckung aus Hi-Tech-Polymer.

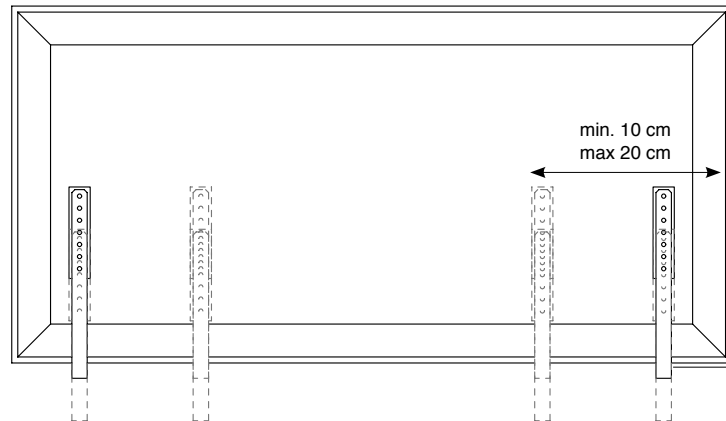

Le staffe possono essere applicate lungo il pannello.

The brackets can be positioned along the panel.

Les supports peuvent être appliqués le long du panneau.

Los soportes pueden ser posicionados a lo largo del panel.

Die Halterungen können beliebig entlang des Paneels angebracht werden.

min. 0,5 cm
max 5 cm

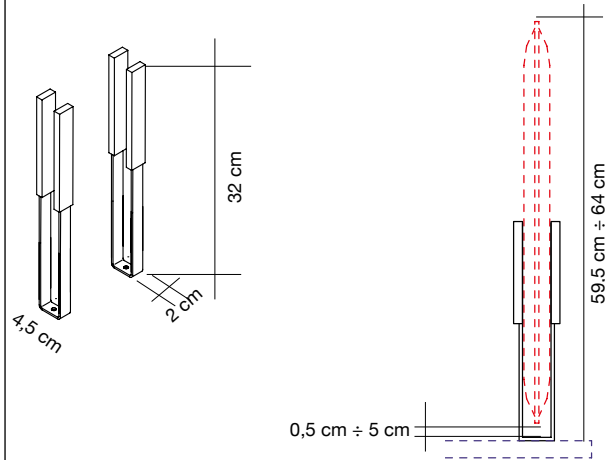
**7S511-GA**

Grigio argento
Silver grey
Gris argenté
Gris plata
Silbergrau

1 coppia / 1 pair
1 paire / 1 pare
1 Paar

Coppia staffe in acciaio verniciato con polveri epossidiche per fissaggio sopra il piano della scrivania tramite viti (non incluse). Attacchi al pannello Snowdesk e coperture in tecnopolimero grigio o bianco. **Per pannelli Snowdesk pag. 28.**

Pair of brackets in powder-coated steel to be fixed on the desk top with screws (not included). Snowdesk panel connections and front covers in grey or white high-tech polymer. **For Snowdesk panels page 28.**

7S511-BO

Bianco opaco
Mat white
Blanc mat
Blanco mate
Mattweiß

1 coppia / 1 pair
1 paire / 1 pare
1 Paar

Paire d'étriers en acier peint époxy pour fixation sur le bureau par des vis (pas incluses). Jonctions au panneau Snowdesk et couvertures en technopolymère gris ou blanc. **Pour panneaux Snowdesk page 28.**

Par de abrazaderas de acero recubierto epoxi para fijación sobre el plan del escritorio por medio de tornillos (no incluidos). Enganches al panel Snowdesk y coberturas de polímero gris o blanco. **Para panels Snowdesk pag. 28.**

1 Paar Halterungen aus pulverbeschichtetem Stahl zur Befestigung auf der Tischplatte durch Schrauben (nicht inkludiert). Snowdesk-Panelbefestigungen und Abdeckungen aus grauem oder weissem Technopolymer. **Für Snowdesk Paneele, Seite 28.**

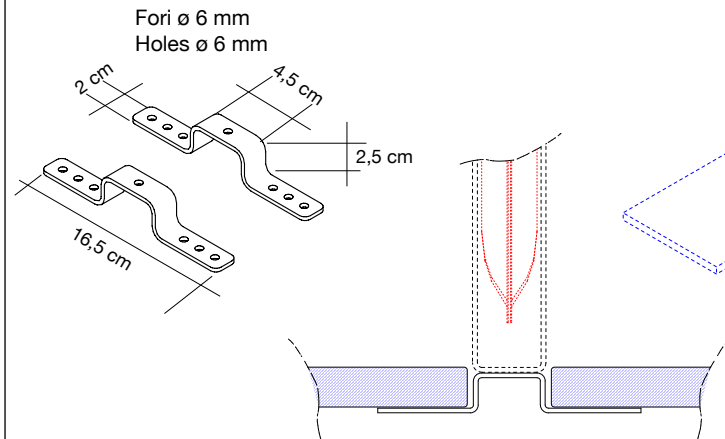
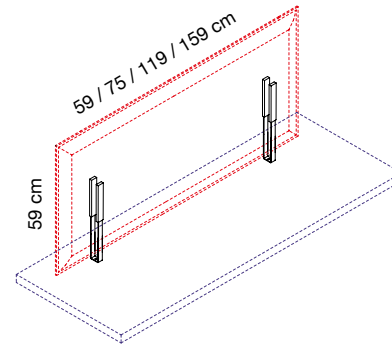
**7S100-GA**

Grigio argento
Silver grey
Gris argenté
Gris plata
Silbergrau

1 coppia / 1 pair
1 paire / 1 pare
1 Paar

Da utilizzare con staffe 7S511-GA / 7S511-BO.

To be used with brackets 7S511-GA / 7S511-BO.

Utiliser avec étriers 7S511-GA / 7S511-BO.

Utilización con abrazaderas 7S511-GA / 7S511-BO.

7S100-BO

Bianco opaco
Mat white
Blanc mat
Blanco mate
Mattweiß

1 coppia / 1 pair
1 paire / 1 pare
1 Paar

Zur Verwendung mit den Halterungen 7S511-GA / 7S511-BO.

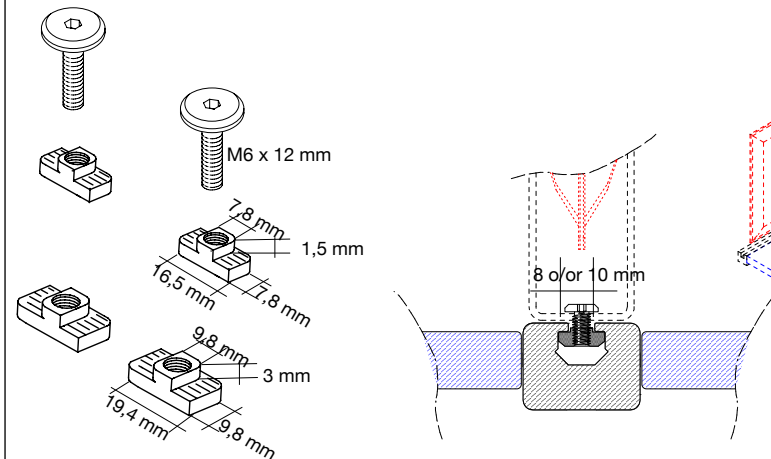
**7S120**

2 coppie / 2 pairs
2 paires / 2 pare
2 Paar

Dadi e viti per profili in alluminio con cava da 8 o 10 mm.

Da utilizzare con staffe 7S511-GA / 7S511-BO.

Nuts and screws for aluminum profiles with hollow 8 or 10 mm. To be used with brackets 7S511-GA / 7S511-BO.

Écrous et vis pour profils en aluminium avec fente de 8 ou 10 mm. À utiliser avec étriers 7S511-GA / 7S511-BO

Tuercas y tornillos para perfiles de aluminio con huecos 8 o 10mm. Para ser utilizado con soportes 7S511-GA / 7S511-BO.

Muttern und Schrauben für Aluminium-Profil mit Nut zu 8 oder 10 mm. Mit Halterungen 7S511-GA / 7S511-BO zu verwenden.

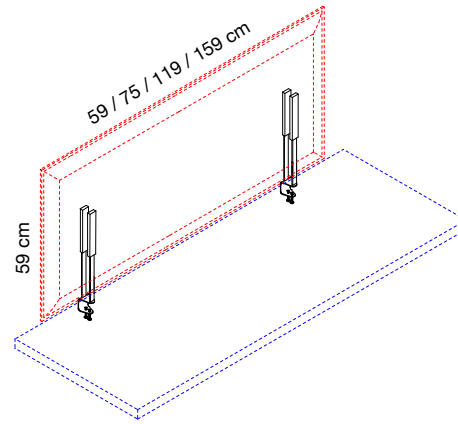
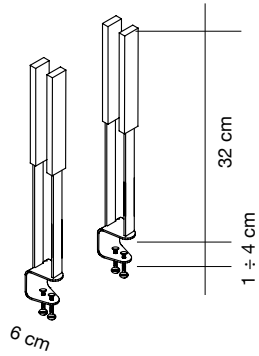

7S1100-GA

Grigio argento
Silver grey
Gris argenté
Gris plata
Silbergrau

1 coppia / 1 pair
1 paire / 1 pare
1 Paar

7S1100-BO

Bianco opaco
Mat white
Blanc mat
Blanco mate
Mattweiß

1 coppia / 1 pair
1 paire / 1 pare
1 Paar

Coppia staffe con morsetto in acciaio verniciato con polveri epossidiche per fissaggio al piano della scrivania. Attacchi al pannello Snowdesk e coperture in tecnopolimero grigio o bianco. **Per pannelli Snowdesk pag. 28.**

Pair of brackets with clamp in powder-coated steel for connection to the desk top. Snowdesk panel connections and front covers in grey or white high-tech polymer. **For Snowdesk panels page 28.**

Paire d'étriers avec étai en acier peint époxy pour fixation au bureau. Jonctions au panneau Snowdesk et couvertures en technopolymère gris ou blanc. **Pour panneaux Snowdesk page 28.**

Par de abrazaderas con sujetador en acero recubierto epoxi para fijación al plan del escritorio. Enganches al panel Snowdesk y coberturas de polímero gris o blanco. **Para panels Snowdesk pag. 28.**

1 Paar Halterungen aus pulverbeschichtetem Stahl mit Klemmen zur Befestigung an der Tischplatte. Snowdesk-Paneelbefestigungen und Abdeckungen aus grauem oder weissem Technopolymer. **Für Snowdesk Paneele, Seite 28.**

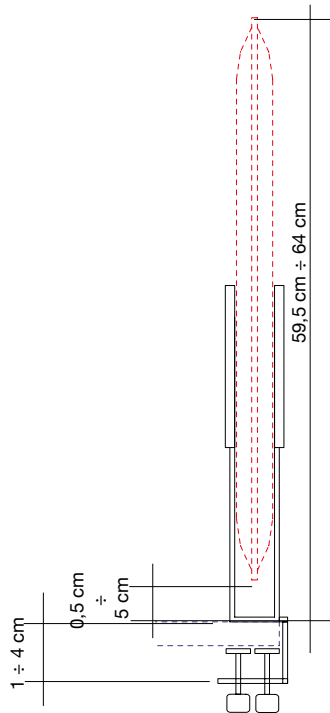

PER APPLICAZIONI A SCRIVANIA - DESK MOUNTING - MONTAGE SUR LE BUREAU - MONTAJE SOBRE MESAS DE ESCRITORIO - TISCHBEFESTIGUNG

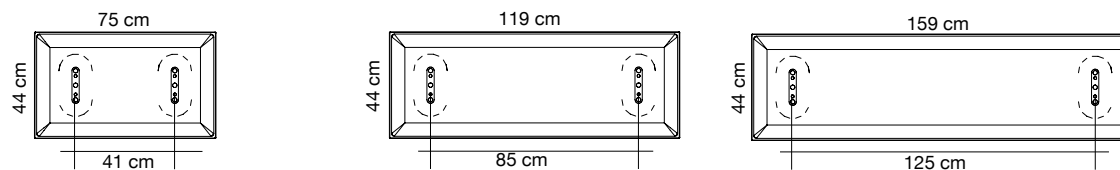

Colore Colour	Codice/Code Prezzo/Price	Codice/Code Prezzo/Price	Codice/Code Prezzo/Price
Bianco White Blanc	0001 7M084-0001	7M124-0001	7M164-0001
Grigio argento Silver grey Gris argenté	8004 7M084-8004	7M124-8004	7M164-8004
Grigio scuro Dark grey Gris foncé	8007 7M084-8007	7M124-8007	7M164-8007
Beige Beige Beige	1008 7M084-1008	7M124-1008	7M164-1008
Tortora Dove-grey Taupe	2005 7M084-2005	7M124-2005	7M164-2005
Giallo Yellow Jaune	3008 7M084-3008	7M124-3008	7M164-3008
Arancione Orange Orange	4030 7M084-4030	7M124-4030	7M164-4030
Rosso Red Rouge	4027 7M084-4027	7M124-4027	7M164-4027
Verde chiaro Light green Vert clair	7004 7M084-7004	7M124-7004	7M164-7004
Verde Green Vert	7013 7M084-7013	7M124-7013	7M164-7013
Blu Blue Bleu	6071 7M084-6071	7M124-6071	7M164-6071
Nero Black Noir	8033 7M084-8033	7M124-8033	7M164-8033

Pannello con imbottitura interna in poliester a **densità variabile** Snowsound® Technology. Rivestimento esterno in tessuto di poliester Trevira CS®.

Panel with polyester internal padding with Snowsound® Technology **variable density**. Polyester covering in Trevira CS® fabric.

Panneau avec rembourrage interne en polyester à **densité variable** Snowsound® Technology. Revêtement externe en tissu de polyester Trevira CS®.

Panel con acolchado interior de poliéster de **densidad variable** Snowsound® Technology. Revestimiento exterior de tejido de poliéster Trevira CS®.

Panel mit Polyester-Füllmaterial von **unterschiedlicher Dichte** Snowsound® Technology. Polyester-Bezug aus Trevira CS®-Material.

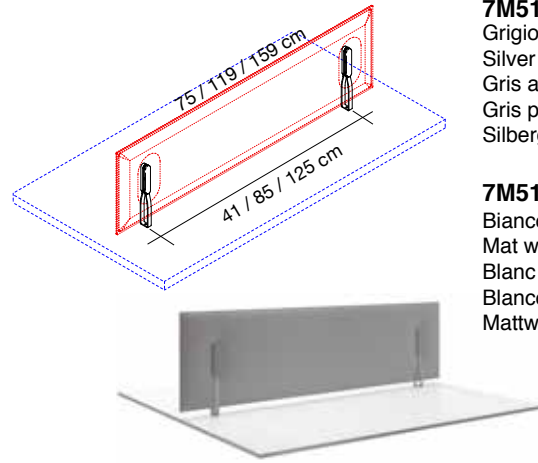
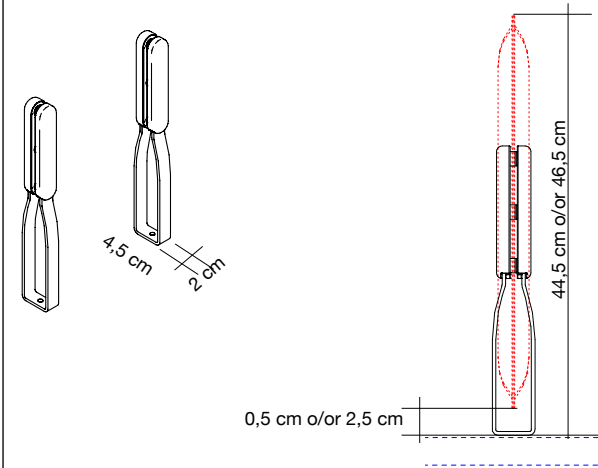

7M511-GA

Grigio argento
Silver grey
Gris argenté
Gris plata
Silbergrau

1 coppia / 1 pair
1 paire / 1 pare
1 Paar

7M511-BO

Bianco opaco
Mat white
Blanc mat
Blanco mate
Mattweiß

1 coppia / 1 pair
1 paire / 1 pare
1 Paar

Coppia staffe in acciaio verniciato con polveri epossidiche per fissaggio sopra il piano della scrivania tramite viti (non incluse). Attacchi al pannello Mitesco e coperture in tecnopolimero grigio o bianco. **Per pannelli Mitesco Desk pag. 32.**

Pair of brackets in powder-coated steel to be fixed on the desk top with screws (not included). Mitesco Panel connections and front covers in grey or white high-tech polymer. **For Mitesco Desk panels page 32.**

Paire d'étriers en acier peint époxy pour fixation sur le bureau par des vis (pas incluses). Jonctions au panneau Mitesco et couvertures en technopolymère gris ou blanc. **Pour panneaux Mitesco Desk page 32.**

Par de abrazaderas de acero recubierto epoxi para fijación sobre el plan del escritorio por medio de tornillos (no incluidos). Enganches al panel Mitesco y coberturas de polímero gris o blanco. **Para panels Mitesco Desk pag. 32.**

1 Paar Halterungen aus pulverbeschichtetem Stahl zur Befestigung auf der Tischplatte durch Schrauben (nicht inkludiert). Mitesco-Panelbefestigungen und Abdeckungen aus grauem oder weissem Technopolymer. **Für Mitesco Desk Paneele, Seite 32.**

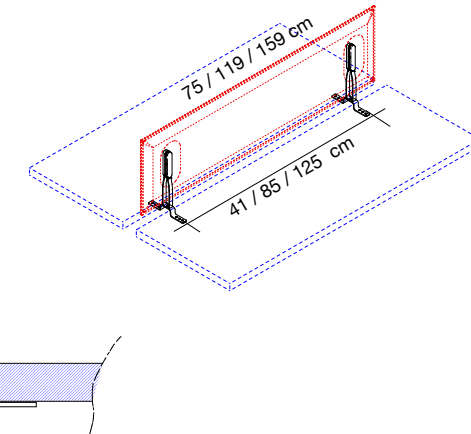
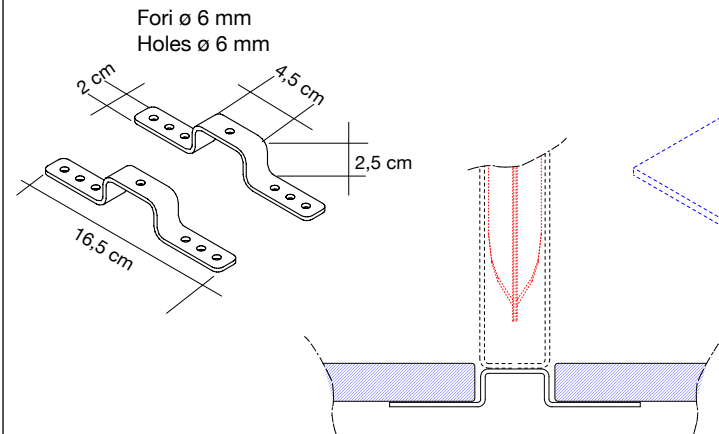

7S100-GA

Grigio argento
Silver grey
Gris argenté
Gris plata
Silbergrau

1 coppia / 1 pair
1 paire / 1 pare
1 Paar

7S100-BO

Bianco opaco
Mat white
Blanc mat
Blanco mate
Mattweiß

1 coppia / 1 pair
1 paire / 1 pare
1 Paar

Da utilizzare con staffe 7M511-GA / 7M511-BO.

To be used with brackets 7M511-GA / 7M511-BO.

Utiliser avec étriers 7M511-GA / 7M511-BO.

Utilización con abrazaderas 7M511-GA / 7M511-BO.

Zur Verwendung mit den Halterungen 7M511-GA / 7M511-BO.

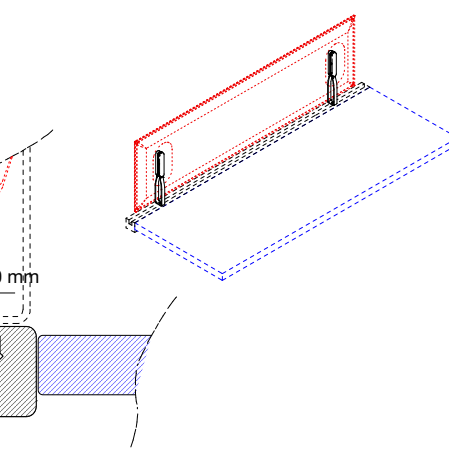
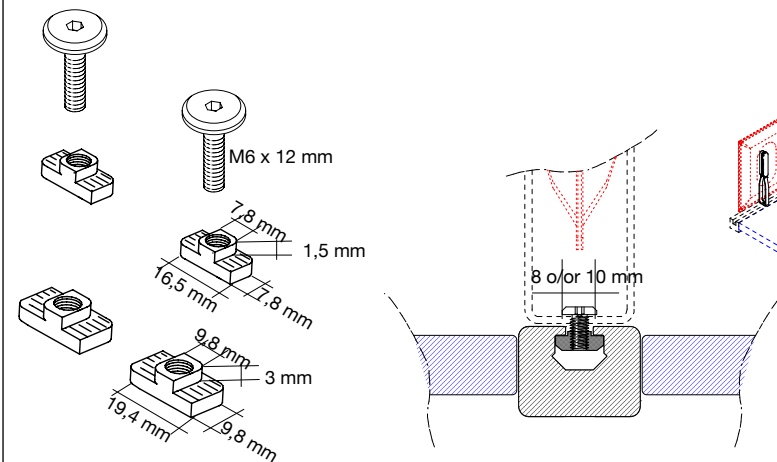

7S120

2 coppie / 2 pairs
2 paires / 2 pare
2 Paar

Dadi e viti per profili in alluminio con cava da 8 o 10 mm. Da utilizzare con staffe 7M511-GA / 7M511-BO.

Nuts and screws for aluminum profiles with hollow 8 or 10 mm. To be used with brackets 7M511-GA / 7M511-BO.

Écrous et vis pour profils en aluminium avec fente de 8 ou 10 mm. À utiliser avec étriers 7M511-GA / 7M511-BO.

Tuercas y tornillos para perfiles de aluminio con huecos 8 o 10 mm. Utilización con abrazaderas 7M511-GA / 7M511-BO.

Muttern und Schrauben für Aluminium-Profil mit Nut zu 8 oder 10 mm. Mit Halterungen 7M511-GA / 7M511-BO zu verwenden.

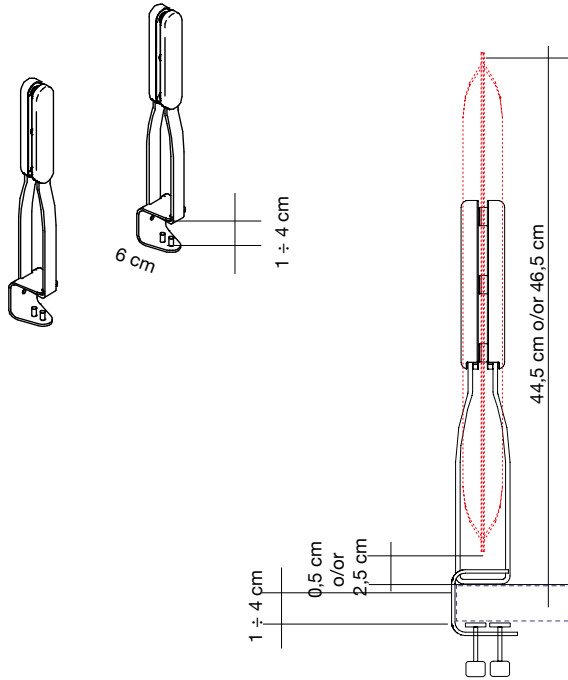
**7M5100-GA**

Grigio argento
Silver grey
Gris argenté
Gris plata
Silbergrau

1 coppia / 1 pair
1 paire / 1 pare
1 Paar

7M5100-BO

Bianco opaco
Mat white
Blanc mat
Blanco mate
Mattweiß

1 coppia / 1 pair
1 paire / 1 pare
1 Paar

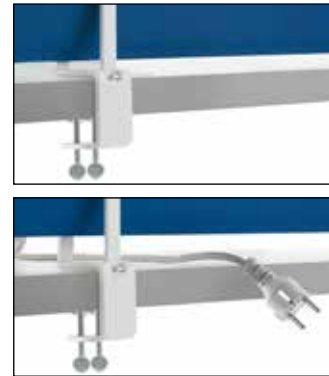

Coppia staffe con morsetto in acciaio verniciato con polveri epossidiche per fissaggio al piano della scrivania.
Attacchi al pannello Mitesco e coperture in tecnopolimero grigio o bianco. **Per pannelli Mitesco Desk pag. 32.**

Pair of brackets with clamp in powder-coated steel for connection to the desk top. Mitesco panel connections and front covers in grey or white high-tech polymer. **For Mitesco Desk panels page 32.**

Paire d'étriers avec étau en acier peint époxy pour fixation au bureau. Jonctions au panneau Mitesco et couvertures en technopolymère gris ou blanc. **Pour panneaux Mitesco Desk page 32.**

Par de abrazaderas con sujetador de acero recubierto epoxi para fijación al plan del escritorio.
Enganches al panel Mitesco y coberturas de polímero gris o blanco. **Para panels Mitesco Desk pag. 32.**

1 Paar Halterungen aus pulverbeschichtetem Stahl mit Klemmen zur Befestigung an der Tischplatte. Mitesco-Paneelebefestigungen und Abdeckungen aus grauem oder weissem Technopolymer. **Für Mitesco Desk Paneele, Seite 32.**

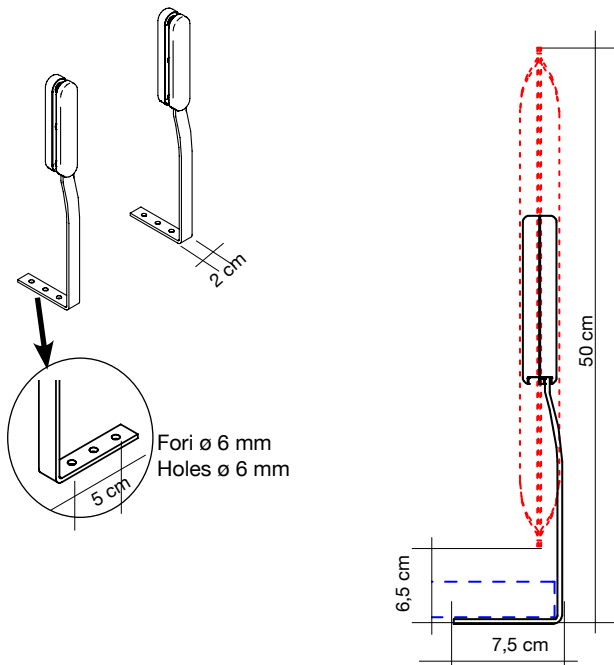
**7M515-GA**

Grigio argento
Silver grey
Gris argenté
Gris plata
Silbergrau

1 coppia / 1 pair
1 paire / 1 pare
1 Paar

7M515-BO

Bianco opaco
Mat white
Blanc mat
Blanco mate
Mattweiß

1 coppia / 1 pair
1 paire / 1 pare
1 Paar

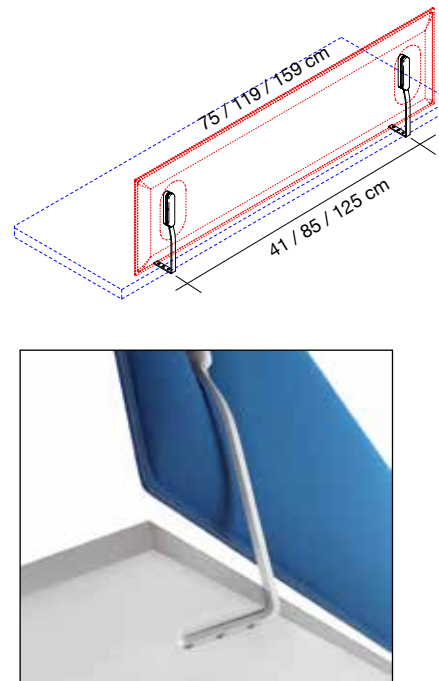

Coppia staffe in acciaio verniciato con polveri epossidiche per fissaggio sotto il piano della scrivania tramite viti (non incluse).
Attacchi al pannello Mitesco e coperture in tecnopolimero grigio o bianco. **Per pannelli Mitesco Desk pag. 32.**

Pair of brackets in powder-coated steel to be fixed under the desk top with screws (not included). Mitesco panel connections and front covers in grey or white high-tech polymer. **For Mitesco Desk panels page 32.**

Paire d'étriers en acier peint époxy pour fixation au dessous du le bureau par des vis (pas incluses). Jonctions au panneau Mitesco et couvertures en technopolymère gris ou blanc. **Pour panneaux Mitesco Desk page 32.**

Par de abrazaderas de acero recubierto epoxi para fijación debajo el plan del escritorio por medio de tornillos (no incluidos). Enganches al panel Mitesco y coberturas de polímero gris o blanco. **Para panels Mitesco Desk pag. 32.**

1 Paar Halterungen aus pulverbeschichtetem Stahl zur Befestigung unter der Tischplatte durch Schrauben (nicht inkludiert). Mitesco-Paneelebefestigungen und Abdeckungen aus grauem oder weissem Technopolymer. **Für Mitesco Desk Paneele, Seite 32.**

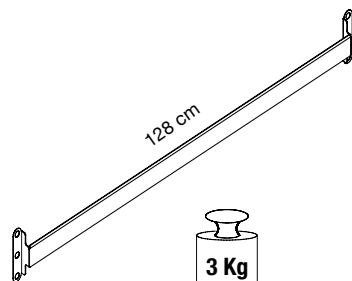

Portata massima
Maximum load

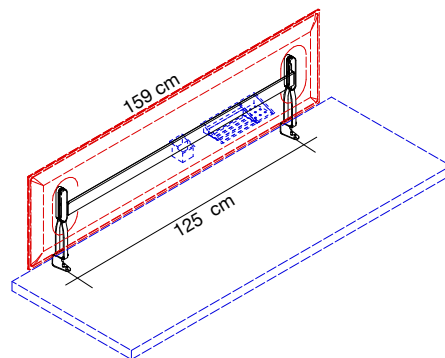

7M546-GA
Grigio argento
Silver grey
Gris argenté
Gris plata
Silbergrau

7M546-BO
Bianco opaco
Mat white
Blanc mat
Blanco mate
Mattweiß

Barra porta accessori Desk-Up realizzata in acciaio verniciato con polveri epossidiche.
Da utilizzare con staffe 7M5100-GA / 7M5100-BO / 7M515-GA / 7M515-BO

Epoxy powder-coated steel toolbar for Desk-Up accessories.
To be used with brackets 7M5100-GA / 7M5100-BO / 7M515-GA / 7M515-BO.

Profil pour accessoires Desk-Up en acier peint en époxy.
Utiliser avec étriers 7M5100-GA / 7M5100-BO / 7M515-GA / 7M515-BO.

Perfil para accesorios Desk-Up realizado de acero recubierto epoxi.
Utilizacion con abrazaderas 7M5100-GA / 7M5100-BO / 7M515-GA / 7M515-BO.

Systemschiene aus pulverbeschichtetem Stahl für Desk-Up-Schalen. Zur Verwendung mit den Halterungen 7M5100-GA / 7M5100-BO / 7M515-GA / 7M515-BO.

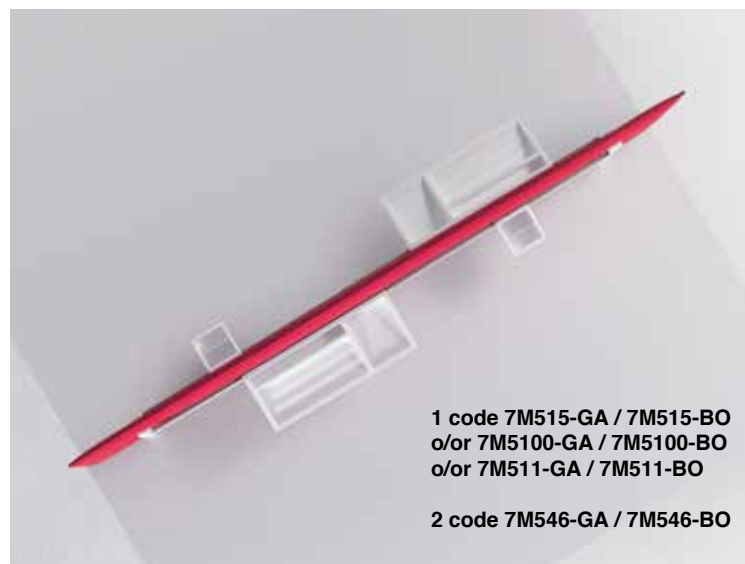

1 code 7M515-GA / 7M515-BO
o/or 7M5100-GA / 7M5100-BO
o/or 7M511-GA / 7M511-BO

2 code 7M546-GA / 7M546-BO

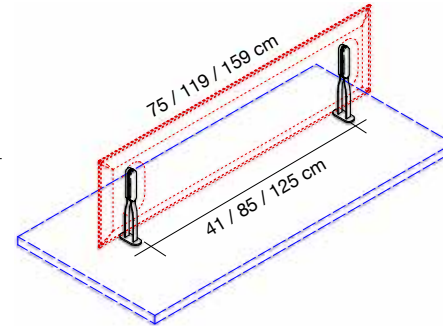
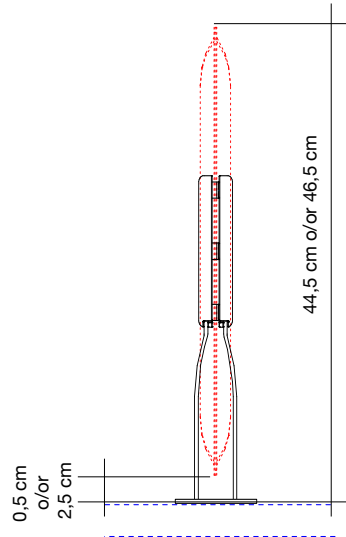
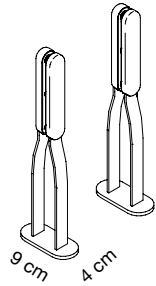
**7M517-GA**

Grigio argento
Silver grey
Gris argenté
Gris plata
Silbergrau

1 coppia / 1 pair
1 paire / 1 pare
1 Paar

7M517-BO

Bianco opaco
Mat white
Blanc mat
Blanco mate
Mattweiß

1 coppia / 1 pair
1 paire / 1 pare
1 Paar

Coppia staffe con base in acciaio verniciato con polveri epossidiche per fissaggio al piano della scrivania. Fissaggio al piano obbligatorio a cura del cliente. Scegliere il tipo di fissaggio / incollaggio idoneo alla superficie del piano. Attacchi al pannello Mitesco e coperture in tecnopolimero grigio o bianco. **Per pannelli Mitesco Desk pag. 32.**

Pair of brackets with base in powder coated steel for fixing to the desk top. Mandatory fastening to the top at customer's care. Choose the most suitable connection/gluing for the surface. Mitesco panel connections and front covers in grey or white high-tech polymer. **For Mitesco Desk panels p. 32.**

Paire d'étriers avec base en acier peint en époxy à fixer au dessus du bureau. Fixation au dessus obligatoire de la part du client. Choisir le type d'accrochage/collage adapté à la surface du dessus. Accrochages au panneau Mitesco et couvertures en technopolymère gris ou blanc. **Pour panneaux Mitesco Desk page 32.**

Par de abrazaderas con base de acero recubierto epoxi para fijacion al plan del escritorio. Enganche al plano obligatorio por parte del cliente. Elegir el tipo de sujetador / enlace lo mas adecuado para la superficie del plano. Enganches al panel Mitesco y coberturas en polimero gris o blanco. **Para panels Mitesco Desk pag. 32.**

1 Paar Halterungen mit Standfüßen aus pulverbeschichtetem Stahl zur Befestigung auf der Tischplatte. Befestigung durch den Kunden unbedingt erforderlich. Wählen Sie die am besten geeignete Art der Verbindung/Verklebung für die betreffende Oberfläche. Mitesco-Paneelbefestigungen und Abdeckungen aus grauem oder weißem Technopolymer. **Für Mitesco Desk Paneele, Seite 32.**

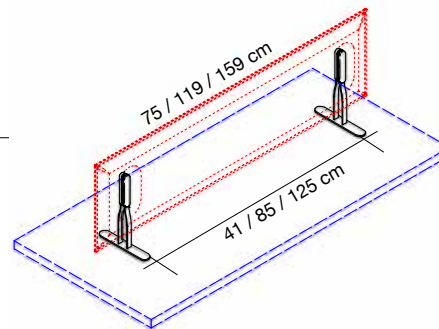
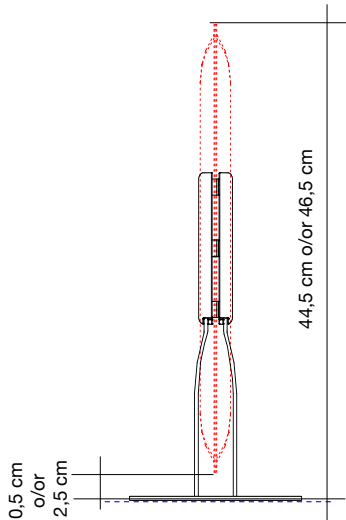
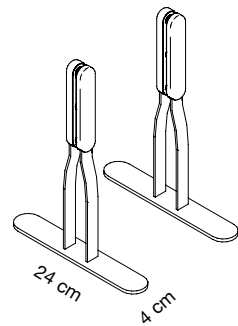
**7M519-GA**

Grigio argento
Silver grey
Gris argenté
Gris plata
Silbergrau

1 coppia / 1 pair
1 paire / 1 pare
1 Paar

7M519-BO

Bianco opaco
Mat white
Blanc mat
Blanco mate
Mattweiß

1 coppia / 1 pair
1 paire / 1 pare
1 Paar

Coppia staffe con base in acciaio verniciato con polveri epossidiche per appoggio al piano della scrivania. Attacchi al pannello Mitesco e coperture in tecnopolimero grigio o bianco. **Per pannelli Mitesco Desk pag. 32.**

Pair of brackets with base in powder coated steel for desk top stand. Mitesco panel connections and front covers in grey or white high-tech polymer. **For Mitesco Desk panels page 32.**

Paire d'étriers avec base en acier peint en époxy à poser sur le dessus du bureau. Accrochages au panneau Mitesco et couvertures en technopolymère gris ou blanc. **Pour panneaux Mitesco Desk page 32.**

Par de abrazaderas con base de acero recubierto epoxi para apoyar al escritorio. Enganches al panel Mitesco y coberturas en polimero gris o blanco. **Para panels Mitesco Desk pag. 32.**

Paar Halterungen mit Standfüßen aus pulverbeschichtetem Stahl zur Aufstellung auf der Tischplatte. Mitesco-Paneelbefestigungen und Abdeckungen aus grauem oder weißem Technopolymer. **Für Mitesco Desk Paneele, Seite 32.**

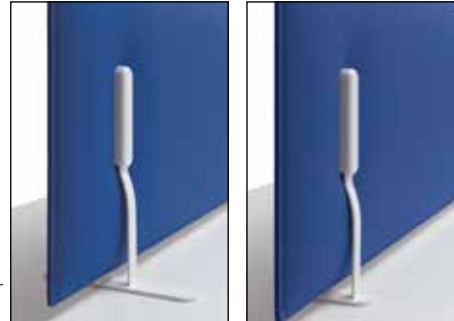
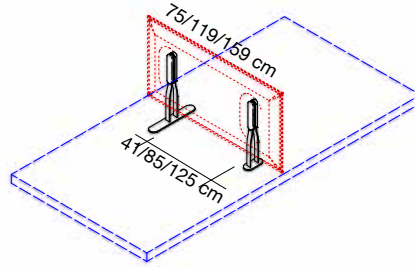
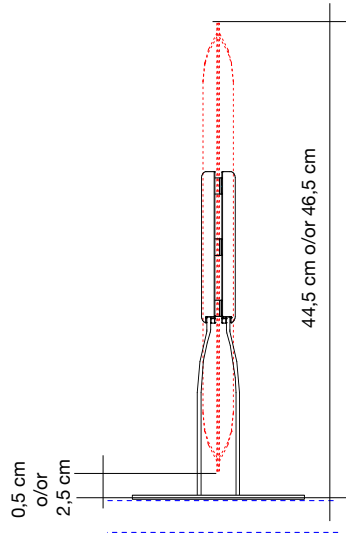
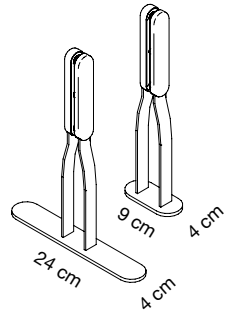

7M518-GA

Grigio argento
Silver grey
Gris argenté
Gris plata
Silbergrau

1 coppia / 1 pair
1 paire / 1 pare
1 Paar

7M518-BO

Bianco opaco
Mat white
Blanc mat
Blanco mate
Mattweiß

1 coppia / 1 pair
1 paire / 1 pare
1 Paar

Coppia staffe con base in acciaio verniciato con polveri epossidiche per appoggio al piano della scrivania.
Attacchi al pannello Mitesco e coperture in tecnopolimero grigio o bianco. **Per pannelli Mitesco Desk pag. 32.**

Pair of brackets with base in powder coated steel for desk top stand.

Mitesco panel connections and front covers in grey or white high-tech polymer. **For Mitesco Desk panels page 32.**

Paire d'étriers avec base en acier peint en époxy à poser sur le dessus du bureau.

Accrochages au panneau Mitesco et couvertures en technopolymère gris ou blanc. **Pour panneaux Mitesco Desk page 32.**

Par de abrazaderas con base de acero recubierto epoxi para apoyar al escritorio.

Enganches al panel Mitesco y coberturas en polímero gris o blanco. **Para panels Mitesco Desk pag. 32.**

Paar Halterungen mit Standfüßen aus pulverbeschichtetem Stahl zur Aufstellung auf der Tischplatte.

Mitesco-Panelbefestigungen und Abdeckungen aus grauem oder weißem Technopolymer. **Für Mitesco Desk Paneele, Seite 32.**

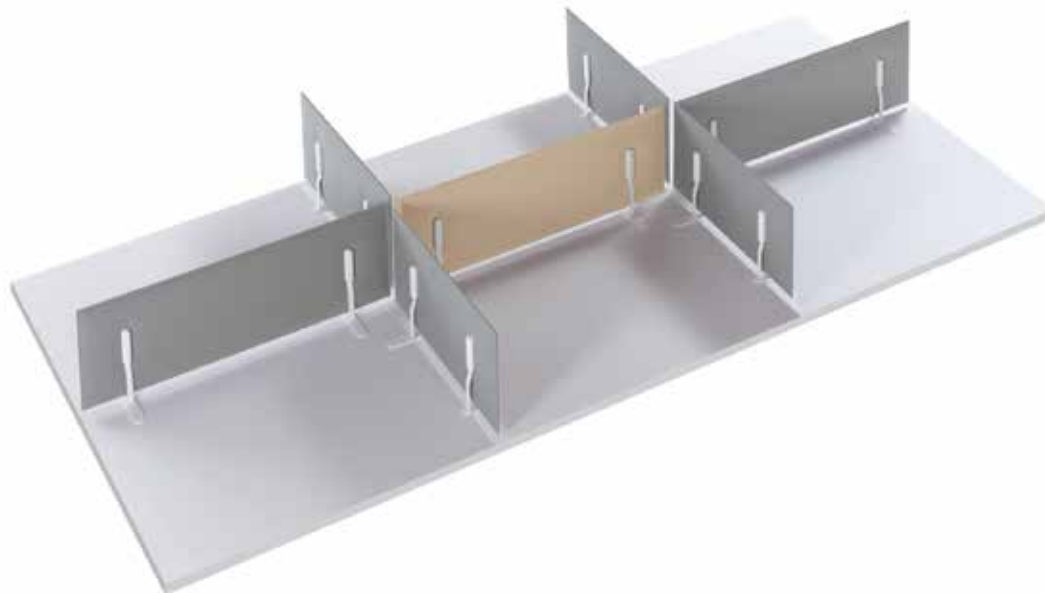

PER APPLICAZIONI A SCRIVANIA - DESK MOUNTING - MONTAGE SUR LE BUREAU
MONTAJE SOBRE MESAS DE ESCRITORIO - TISCHBEFESTIGUNG

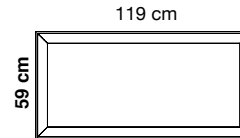
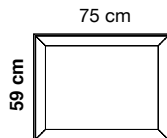
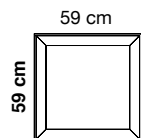

Colore Colour	Codice/Code Prezzo/Price	Codice/Code Prezzo/Price	Codice/Code Prezzo/Price
Bianco White Blanc	0001	7B0606-0001	7B0806-0001
Grigio argento Silver grey Gris argenté	8004	7B0606-8004	7B0806-8004
Grigio scuro Dark grey Gris foncé	8007	7B0606-8007	7B0806-8007
Beige Beige Beige	1008	7B0606-1008	7B0806-1008
Tortora Dove-grey Taupe	2005	7B0606-2005	7B0806-2005
Giallo Yellow Jaune	3008	7B0606-3008	7B0806-3008
Arancione Orange Orange	4030	7B0606-4030	7B0806-4030
Rosso Red Rouge	4027	7B0606-4027	7B0806-4027
Verde chiaro Light green Vert clair	7004	7B0606-7004	7B0806-7004
Mattone Brick red Rouge brique	4086	7B0606-4086	7B0806-4086
Azzurro Light blue Bleu clair	6046	7B0606-6046	7B0806-6046
Ottanio Teal Sarcelle	6075	7B0606-6075	7B0806-6075

Pannello con imbottitura interna in poliester a **densità variabile** Snowsound® Technology. Rivestimento esterno in tessuto di poliester Trevira CS®.

Panel with polyester internal padding with Snowsound® Technology **variable density**. Polyester covering in Trevira CS® fabric.

Panneau avec rembourrage interne en polyester à **densité variable** Snowsound® Technology. Revêtement externe en tissu de polyester Trevira CS®.

Panel con acolchado interior de poliéster de **densidad variable** Snowsound® Technology. Revestimiento exterior de tejido de poliéster Trevira CS®.

Panel mit Polyester-Füllmaterial von **unterschiedlicher Dichte** Snowsound® Technology. Polyester-Bezug aus Trevira CS®-Material.

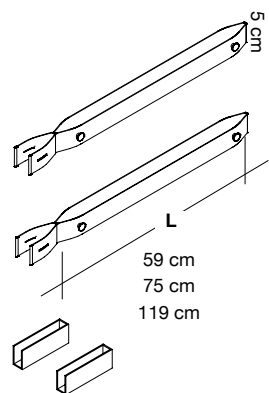

7BC306-GR

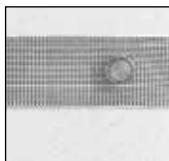

Per pannelli
For panels
L. 59 cm

Coppia cinghie elastiche in tecnopolimero per pannello Pli Desk complete di piedini antiscivolo. **Per pannelli Pli Desk pag. 38.**

Couple of hi-tech polymer elastic straps for Pli Desk panels complete with non-slip feet. **For Pli Desk panels page 38.**

7BC308-GR

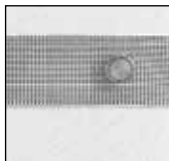

Per pannelli
For panels
L. 75 cm

Paire de sangles élastiques en technopolymère pour panneau Pli desk, vérins antidérapants inclus. **Pour panneaux Pli Desk page 38.**

Par de correas elásticas en tecnopolímero para panel Pli Desk completos con patas antideslizantes. **Para panels Pli Desk pag. 38.**

7BC312-GR

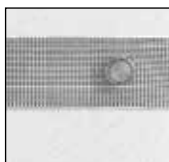

Per pannelli
For panels
L. 119 cm

Elastisches Riemen-Paar aus Technopolymer für das Paneel Pli Desk, das mit rutschfesten Füßchen ausgestattet ist. **Für Pli Desk Paneele, Seite 38.**

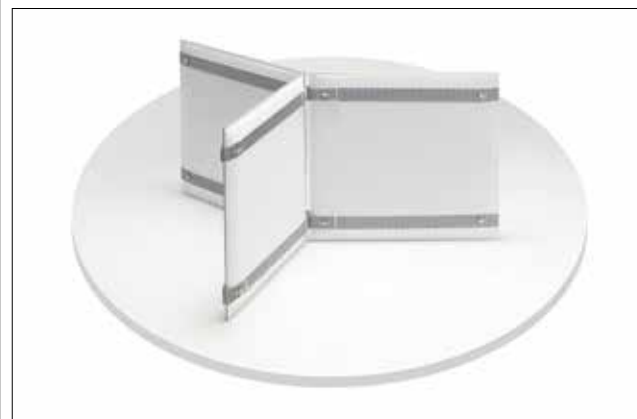

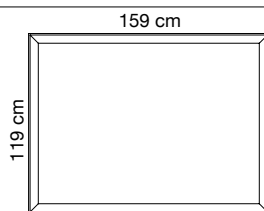
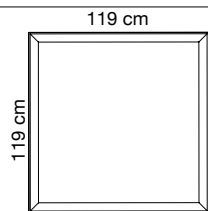

Colore Colour	Codice/Code Prezzo/Price	Codice/Code Prezzo/Price	Codice/Code Prezzo/Price
Bianco White Blanc	0001	7S1212-0001	7S1216-0001
Grigio argento Silver grey Gris argenté	8004	7S1212-8004	7S1216-8004
Grigio scuro Dark grey Gris foncé	8007	7S1212-8007	7S1216-8007
Beige Beige Beige	1008	7S1212-1008	7S1216-1008
Tortora Dove-grey Taupe	2005	7S1212-2005	7S1216-2005
Giallo Yellow Jaune	3008	7S1212-3008	7S1216-3008
Arancione Orange Orange	4030	7S1212-4030	7S1216-4030
Rosso Red Rouge	4027	7S1212-4027	7S1216-4027
Verde chiaro Light green Vert clair	7004	7S1212-7004	7S1216-7004
Mattone Brick red Rouge brique	4086	7S1212-4086	7S1216-4086
Azzurro Light blue Bleu clair	6046	7S1212-6046	7S1216-6046
Ottanio Teal Sarcelle	6075	7S1212-6075	7S1216-6075

Pannello con imbottitura interna in poliester a **densità variabile** Snowsound® Technology. Rivestimento esterno in tessuto di poliester Trevira CS®.

Panel with polyester internal padding with Snowsound® Technology **variable density**. Polyester covering in Trevira CS® fabric.

Panneau avec rembourrage interne en polyester à **densité variable** Snowsound® Technology. Revêtement externe en tissu de polyester Trevira CS®.

Panel con acolchado interior de poliéster de **densidad variable** Snowsound® Technology. Revestimiento exterior de tejido de poliéster Trevira CS®.

Panel mit Polyester-Füllmaterial von **unterschiedlicher Dichte** Snowsound® Technology. Polyester-Bezug aus Trevira CS®-Material.

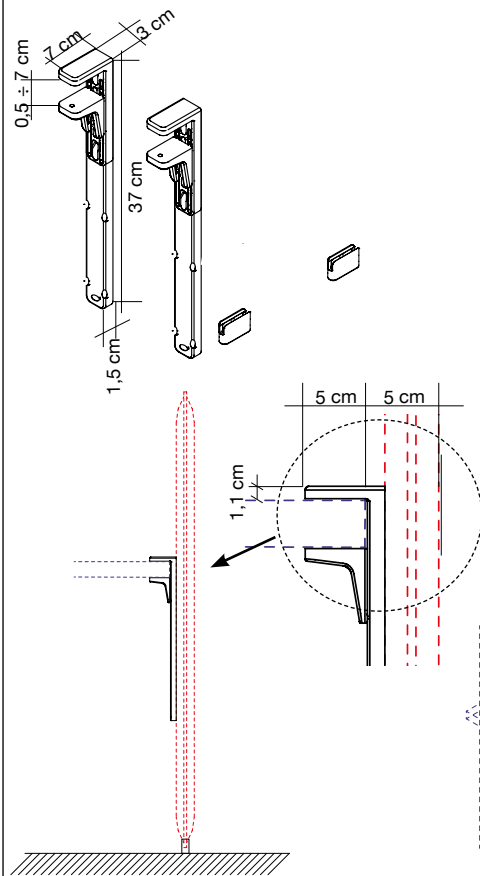

7S320-GA

Grigio argento
Silver grey
Gris argenté
Gris plata
Silbergrau

1 coppia / 1 pair
1 paire / 1 pare
1 Paar

7S320-BO

Bianco opaco
Mat white
Blanc mat
Blanco mate
Mattweiß

1 coppia / 1 pair
1 paire / 1 pare
1 Paar

Coppia attacchi con morsetto regolabile in alluminio e acciaio verniciato con polveri epossidiche per fissaggio al piano della scrivania. Completo di piedini in tecnopolimero e acciaio per l'appoggio a terra del pannello. **Per pannelli Oversize Desk pag. 40.**

Pair of brackets with adjustable clamp in powder-coated steel and aluminium for connection to the desk top. Complete with hi-tech polymer and steel small feet for the floor support of the panel. **For Oversize Desk panels page 40.**

Paire d'étriers avec étau réglable en acier et aluminium peint époxy pour fixation au bureau. Avec vérins en technopolymère et acier pour l'appui au sol du panneau. **Pour panneaux Oversize Desk page 40.**

Par de abrazaderas con sujetador ajustable en acero y aluminio recubierto epoxi para fijación al plan del escritorio. Completo con patas en tecnopolímero y acero para el apoyo en el suelo del panel. **Para panels Oversize Desk pag. 40.**

1 Paar Halterungen aus pulverbeschichtetem Stahl und Aluminium mit einstellbare Klemmen zur Befestigung an der Tischplatte. Mit Technopolymer- und Stahl-Füßchen ausgestattet, damit das Paneel auch auf den Boden gestellt werden kann. **Für Oversize Desk Paneele, Seite 40.**

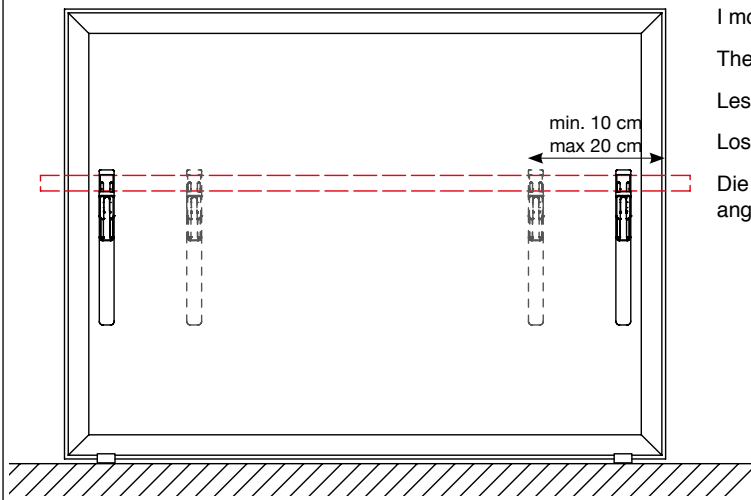

I morsetti possono essere applicati lungo il pannello.

The clamps can be positioned along the panel.

Les étriers peuvent être appliqués le long du panneau.

Los abrazaderas pueden ser posicionados a lo largo del panel.

Die Klemmen können beliebig entlang des Paneels angebracht werden.

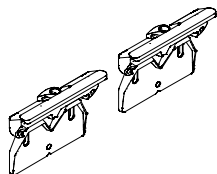

**7S370-BO**

Bianco opaco
Mat white
Blanc mat
Blanco mate
Mattweiß

1 coppia / 1 pair
1 paire / 1 pare
1 Paar

Coppia attacchi a parete in zama verniciata o nichel satinata.

Pair of wall fixings in zamac, painted or nickel satinied

Paire de fixations murales en zamac peinte ou nickel satinée.

7S370-C

Nichel satinato
Nickel satinied
Nickel satinée
Niquel satinado
Nickel satiniert

1 coppia / 1 pair
1 paire / 1 pare
1 Paar

Set de fijaciones a pared en zamac, pintado o niquel satinado.

1 Paar Wandbefestigungen aus Zamac, beschichtet oder Nickel satiniert

ATTENZIONE: il simbolo ▲ riportato sui pannelli di pag. 43-44-45-46-47 indica il numero di attacchi necessari per il corretto fissaggio parete (attenzione: gli attacchi sono venduti a coppie)

WARNING: the symbol ▲ as depicted on the panels (pages 43-44-45-46-47) indicates the required number of connections for the correct wall fixing (warning: fixings are sold in pairs)

ATTENTION: le symbole ▲ sur les panneaux aux pages 43-44-45-46-47 indique la quantité de joints nécessaires pour une correcte fixation au mur (attention: les joints sont vendus en paire)

Advertencia: el símbolo ▲ representado en los paneles pag 43-44-45-46-47 indica el número necesario de conexiones para su correcta fijación a pared (se venden en set de 2 pzs)

ACHTUNG: das auf den Paneelen abgebildete Symbol ▲ (Seiten 43-44-45-46-47) bezeichnet die erforderliche Anzahl von Halterungen für die korrekte Wandmontage (Achtung: die Wandbefestigungen sind nur paarweise erhältlich)



Nichel satinato - Nickel satinied - Nickel satinée - Niquel satinado
Nickel satiniert

Bianco opaco - Mat white - Blanc mat - Blanco mate - Mattweiß



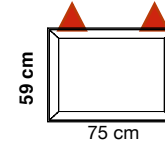
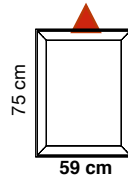
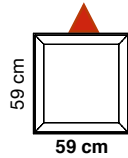

Colore Colour	Codice/Code Prezzo/Price	Codice/Code Prezzo/Price	Codice/Code Prezzo/Price
Bianco White Blanc	0001	7S066-0001	7S086-0001
Grigio argento Silver grey Gris argenté	8004	7S066-8004	7S086-8004
Grigio scuro Dark grey Gris foncé	8007	7S066-8007	7S086-8007
Beige Beige Beige	1008	7S066-1008	7S086-1008
Tortora Dove-grey Taupe	2005	7S066-2005	7S086-2005
Giallo Yellow Jaune	3008	7S066-3008	7S086-3008
Arancione Orange Orange	4030	7S066-4030	7S086-4030
Rosso Red Rouge	4027	7S066-4027	7S086-4027
Verde chiaro Light green Vert clair	7004	7S066-7004	7S086-7004
Mattone Brick red Rouge brique	4086	7S066-4086	7S086-4086
Azzurro Light blue Bleu clair	6046	7S066-6046	7S086-6046
Ottanio Teal Sarcelle	6075	7S066-6075	7S086-6075

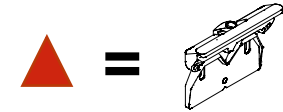

ATTENZIONE: attacchi non compresi. Vedi pag. 42

WARNING: fixings not included. See page 42

ATTENTION: fixations pas incluses. Voir à la page 42

ADVERTENCIA: fijaciones no incluidas. Ver página 42

ACHTUNG: Befestigungen nicht enthalten. Sehen Sie an der Seite 42

Pannello con imbottitura interna in poliester a **densità variabile** Snowsound® Technology. Rivestimento esterno in tessuto di poliester Trevira CS®.

Panel with polyester internal padding with Snowsound® Technology **variable density**. Polyester covering in Trevira CS® fabric.

Panneau avec rembourrage interne en polyester à **densité variable** Snowsound® Technology. Revêtement externe en tissu de polyester Trevira CS®.

Panel con acolchado interior de poliéster de **densidad variable** Snowsound® Technology. Revestimiento exterior de tejido de poliéster Trevira CS®.

Panel mit Polyester-Füllmaterial von **unterschiedlicher Dichte** Snowsound® Technology. Polyester-Bezug aus Trevira CS®-Material.

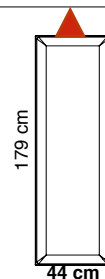
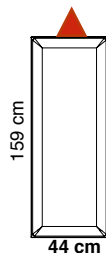
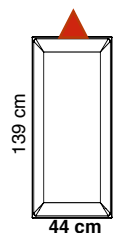
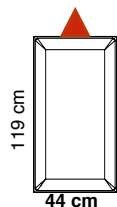
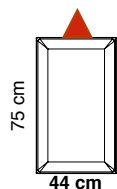

Colore Colour	Codice/Code Prezzo/Price	Codice/Code Prezzo/Price	Codice/Code Prezzo/Price	Codice/Code Prezzo/Price	Codice/Code Prezzo/Price	
Bianco White Blanc	0001	7S408-0001	7S412-0001	7S414-0001	7S416-0001	7S418-0001
Grigio argento Silver grey Gris argenté	8004	7S408-8004	7S412-8004	7S414-8004	7S416-8004	7S418-8004
Grigio scuro Dark grey Gris foncé	8007	7S408-8007	7S412-8007	7S414-8007	7S416-8007	7S418-8007
Beige Beige Beige	1008	7S408-1008	7S412-1008	7S414-1008	7S416-1008	7S418-1008
Tortora Dove-grey Taupe	2005	7S408-2005	7S412-2005	7S414-2005	7S416-2005	7S418-2005
Giallo Yellow Jaune	3008	7S408-3008	7S412-3008	7S414-3008	7S416-3008	7S418-3008
Arancione Orange Orange	4030	7S408-4030	7S412-4030	7S414-4030	7S416-4030	7S418-4030
Rosso Red Rouge	4027	7S408-4027	7S412-4027	7S414-4027	7S416-4027	7S418-4027
Verde chiaro Light green Vert clair	7004	7S408-7004	7S412-7004	7S414-7004	7S416-7004	7S418-7004
Mattone Brick red Rouge brique	4086	7S408-4086	7S412-4086	7S414-4086	7S416-4086	7S418-4086
Azzurro Light blue Bleu clair	6046	7S408-6046	7S412-6046	7S414-6046	7S416-6046	7S418-6046
Ottanio Teal Sarcelle	6075	7S408-6075	7S412-6075	7S414-6075	7S416-6075	7S418-6075



ATTENZIONE: attacchi non compresi. Vedi pag. 42

WARNING: fixings not included. See page 42

ATTENTION: fixations pas incluses. Voir à la page 42

ADVERTENCIA: fijaciones no incluidas. Ver página 42

ACHTUNG: Befestigungen nicht enthalten. Sehen Sie an der Seite 42

Pannello con imbottitura interna in poliestere a **densità variabile** Snowsound® Technology. Rivestimento esterno in tessuto di poliestere Trevira CS®.

Panel with polyester internal padding with Snowsound® Technology **variable density**. Polyester covering in Trevira CS® fabric.

Panneau avec rembourrage interne en polyester à **densité variable** Snowsound® Technology. Revêtement externe en tissu de polyester Trevira CS®.

Panel con acolchado interior de poliéster de **densidad variable** Snowsound® Technology. Revestimiento exterior de tejido de poliéster Trevira CS®.

Panel mit Polyester-Füllmaterial von **unterschiedlicher Dichte** Snowsound® Technology. Polyester-Bezug aus Trevira CS®-Material.

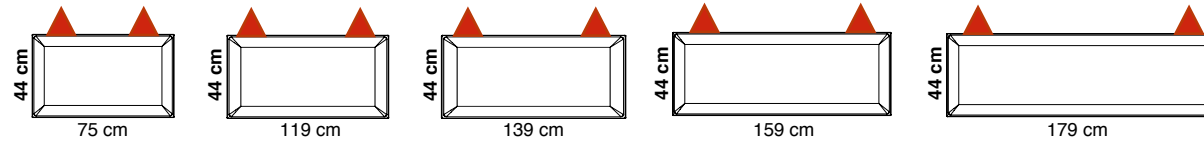

Colore Colour	Codice/Code Prezzo/Price	Codice/Code Prezzo/Price	Codice/Code Prezzo/Price	Codice/Code Prezzo/Price	Codice/Code Prezzo/Price	
Bianco White Blanc	0001	7S408-0001	7S412-0001	7S414-0001	7S416-0001	7S418-0001
Grigio argento Silver grey Gris argenté	8004	7S408-8004	7S412-8004	7S414-8004	7S416-8004	7S418-8004
Grigio scuro Dark grey Gris foncé	8007	7S408-8007	7S412-8007	7S414-8007	7S416-8007	7S418-8007
Beige Beige Beige	1008	7S408-1008	7S412-1008	7S414-1008	7S416-1008	7S418-1008
Tortora Dove-grey Taupe	2005	7S408-2005	7S412-2005	7S414-2005	7S416-2005	7S418-2005
Giallo Yellow Jaune	3008	7S408-3008	7S412-3008	7S414-3008	7S416-3008	7S418-3008
Arancione Orange Orange	4030	7S408-4030	7S412-4030	7S414-4030	7S416-4030	7S418-4030
Rosso Red Rouge	4027	7S408-4027	7S412-4027	7S414-4027	7S416-4027	7S418-4027
Verde chiaro Light green Vert clair	7004	7S408-7004	7S412-7004	7S414-7004	7S416-7004	7S418-7004
Mattone Brick red Rouge brique	4086	7S408-4086	7S412-4086	7S414-4086	7S416-4086	7S418-4086
Azzurro Light blue Bleu clair	6046	7S408-6046	7S412-6046	7S414-6046	7S416-6046	7S418-6046
Ottanio Teal Sarcelle	6075	7S408-6075	7S412-6075	7S414-6075	7S416-6075	7S418-6075



ATTENZIONE: attacchi non compresi. Vedi pag. 42

WARNING: fixings not included. See page 42

ATTENTION: fixations pas incluses. Voir à la page 42

ADVERTENCIA: fijaciones no incluidas. Ver página 42

ACHTUNG: Befestigungen nicht enthalten. Sehen Sie an der Seite 42

Pannello con imbottitura interna in poliester a **densità variabile** Snowsound® Technology. Rivestimento esterno in tessuto di poliester Trevira CS®.

Panel with polyester internal padding with Snowsound® Technology **variable density**. Polyester covering in Trevira CS® fabric.

Panneau avec rembourrage interne en polyester à **densité variable** Snowsound® Technology. Revêtement externe en tissu de polyester Trevira CS®.

Panel con acolchado interior de poliéster de **densidad variable** Snowsound® Technology. Revestimiento exterior de tejido de poliéster Trevira CS®.

Paneel mit Polyester-Füllmaterial von **unterschiedlicher Dichte** Snowsound® Technology. Polyester-Bezug aus Trevira CS®-Material.

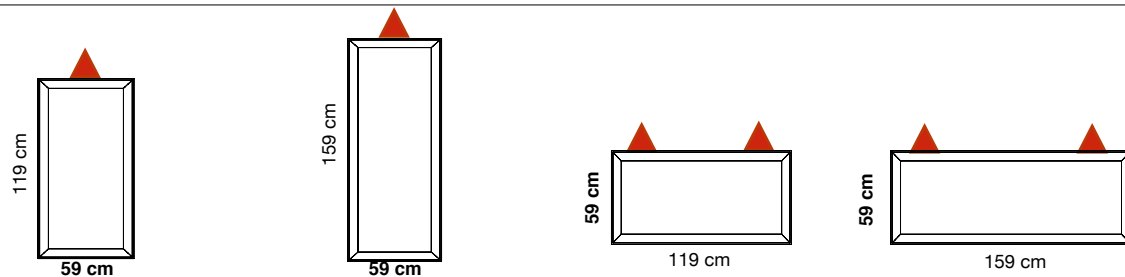

Colore Colour	Codice/Code Prezzo/Price	Codice/Code Prezzo/Price	Codice/Code Prezzo/Price	Codice/Code Prezzo/Price
Bianco White Blanc	0001	7S126-0001	7S166-0001	7S126-0001
Grigio argento Silver grey Gris argenté	8004	7S126-8004	7S166-8004	7S126-8004
Grigio scuro Dark grey Gris foncé	8007	7S126-8007	7S166-8007	7S126-8007
Beige Beige Beige	1008	7S126-1008	7S166-1008	7S126-1008
Tortora Dove-grey Taupe	2005	7S126-2005	7S166-2005	7S126-2005
Giallo Yellow Jaune	3008	7S126-3008	7S166-3008	7S126-3008
Arancione Orange Orange	4030	7S126-4030	7S166-4030	7S126-4030
Rosso Red Rouge	4027	7S126-4027	7S166-4027	7S126-4027
Verde chiaro Light green Vert clair	7004	7S126-7004	7S166-7004	7S126-7004
Mattone Brick red Rouge brique	4086	7S126-4086	7S166-4086	7S126-4086
Azzurro Light blue Bleu clair	6046	7S126-6046	7S166-6046	7S126-6046
Ottanio Teal Sarcelle	6075	7S126-6075	7S166-6075	7S126-6075
Bianco ghiaccio Cool white Blanc glacier	8002	7S126-8002	7S166-8002	7S126-8002



ATTENZIONE: attacchi non compresi. Vedi pag. 42

WARNING: fixings not included. See page 42

ATTENTION: fixations pas incluses. Voir à la page 42

ADVERTENCIA: fijaciones no incluidas. Ver página 42

ACHTUNG: Befestigungen nicht enthalten. Sehen Sie an der Seite 42

Pannello con imbottitura interna in poliester a **densità variabile** Snowsound® Technology. Rivestimento esterno in tessuto di poliester Trevira CS®.

Panel with polyester internal padding with Snowsound® Technology **variable density**. Polyester covering in Trevira CS® fabric.

Panneau avec rembourrage interne en polyester à **densité variable** Snowsound® Technology. Revêtement externe en tissu de polyester Trevira CS®.

Panel con acolchado interior de poliéster de **densidad variable** Snowsound® Technology. Revestimiento exterior de tejido de poliéster Trevira CS®.

Paneel mit Polyester-Füllmaterial von **unterschiedlicher Dichte** Snowsound® Technology. Polyester-Bezug aus Trevira CS®-Material.

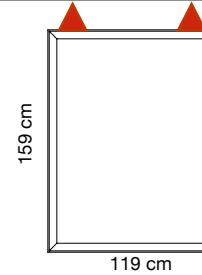
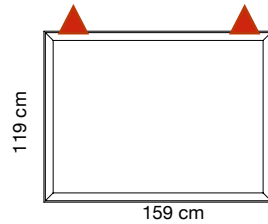
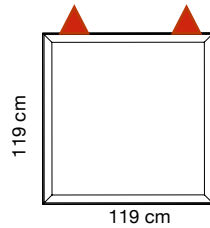

Colore Colour	Codice/Code Prezzo/Price	Codice/Code Prezzo/Price	Codice/Code Prezzo/Price
Bianco White Blanc	0001	7S1212-0001	7S1216-0001
Grigio argento Silver grey Gris argenté	8004	7S1212-8004	7S1216-8004
Grigio scuro Dark grey Gris foncé	8007	7S1212-8007	7S1216-8007
Beige Beige Beige	1008	7S1212-1008	7S1216-1008
Tortora Dove-grey Taupe	2005	7S1212-2005	7S1216-2005
Giallo Yellow Jaune	3008	7S1212-3008	7S1216-3008
Arancione Orange Orange	4030	7S1212-4030	7S1216-4030
Rosso Red Rouge	4027	7S1212-4027	7S1216-4027
Verde chiaro Light green Vert clair	7004	7S1212-7004	7S1216-7004
Mattone Brick red Rouge brique	4086	7S1212-4086	7S1216-4086
Azzurro Light blue Bleu clair	6046	7S1212-6046	7S1216-6046
Ottanio Teal Sarcelle	6075	7S1212-6075	7S1216-6075
Bianco ghiaccio Cool white Blanc glacier	8002	7S1212-8002	7S1216-8002



ATTENZIONE: attacchi non compresi. Vedi pag. 42

WARNING: fixings not included. See page 42

ATTENTION: fixations pas incluses. Voir à la page 42

ADVERTENCIA: fijaciones no incluidas. Ver página 42

ACHTUNG: Befestigungen nicht enthalten. Sehen Sie an der Seite 42

Pannello con imbottitura interna in poliestere a **densità variabile** Snowsound® Technology. Rivestimento esterno in tessuto di poliestere Trevira CS®.

Panel with polyester internal padding with Snowsound® Technology **variable density**. Polyester covering in Trevira CS® fabric.

Panneau avec rembourrage interne en polyester à **densité variable** Snowsound® Technology. Revêtement externe en tissu de polyester Trevira CS®.

Panel con acolchado interior de poliéster de **densidad variable** Snowsound® Technology. Revestimiento exterior de tejido de poliéster Trevira CS®.

Panel mit Polyester-Füllmaterial von **unterschiedlicher Dichte** Snowsound® Technology. Polyester-Bezug aus Trevira CS®-Material.

BAFFLE OVERSIZE

design Marc Sadler

Snowsound® technology by Caimi Brevetti

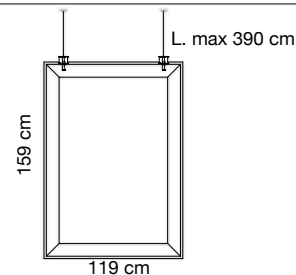
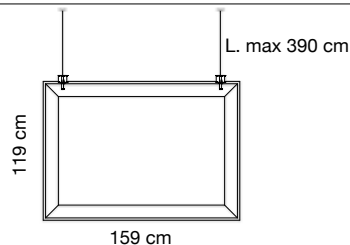
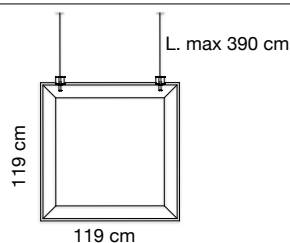
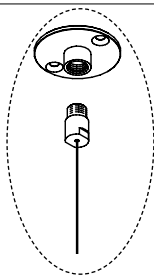

Colore Colour	Codice/Code Prezzo/Price	Codice/Code Prezzo/Price	Codice/Code Prezzo/Price
Bianco White Blanc	0001	7BOF1212-0001	7BOF1216-0001
Grigio argento Silver grey Gris argenté	8004	7BOF1212-8004	7BOF1216-8004
Grigio scuro Dark grey Gris foncé	8007	7BOF1212-8007	7BOF1216-8007
Beige Beige Beige	1008	7BOF1212-1008	7BOF1216-1008
Tortora Dove-grey Taupe	2005	7BOF1212-2005	7BOF1216-2005
Giallo Yellow Jaune	3008	7BOF1212-3008	7BOF1216-3008
Arancione Orange Orange	4030	7BOF1212-4030	7BOF1216-4030
Rosso Red Rouge	4027	7BOF1212-4027	7BOF1216-4027
Verde chiaro Light green Vert clair	7004	7BOF1212-7004	7BOF1216-7004
Mattone Brick red Rouge brique	4086	7BOF1212-4086	7BOF1216-4086
Azzurro Light blue Bleu clair	6046	7BOF1212-6046	7BOF1216-6046
Ottanio Teal Sarcelle	6075	7BOF1212-6075	7BOF1216-6075
Bianco ghiaccio Cool white Blanc glacier	8002	7BOF1212-8002	7BOF1216-8002

Pannello con imbottitura interna in poliester a **densità variabile** Snowsound® Technology. Rivestimento esterno in tessuto di poliester Trevira CS®. Completo di 2 supporti realizzati in pressofusione di metallo cromato che nascondono al loro interno il meccanismo di regolazione dei cavi di fissaggio a soffitto + 2 cavi in acciaio + 2 piastre a soffitto a 2 fori

Panel with polyester internal padding with Snowsound® Technology **variable density**. Polyester covering in Trevira CS® fabric. Complete with 2 supports made of die-cast chrome-plated metal that hide inside the adjustment mechanism of the ceiling fixing cables + 2 ceiling plates with 2 holes, 2 steel cables.

Panneau avec rembourrage interne en polyester à **densité variable** Snowsound® Technology. Revêtement externe en tissu de polyester Trevira CS®. Fourni avec 2 supports en métal chromé moulé sous pression qui cachent le mécanisme de réglage des câbles de fixation au plafond + 2 platines pour plafond à 2 trous - 2 câbles en acier.

Panel con acolchado interior de poliéster de **densidad variable** Snowsound® Technology. Revestimiento exterior de tejido de poliéster Trevira CS®. Se completa con 2 soportes de metal fundido cromado que llevan dentro, escondido, el mecanismo de ajuste de los cables de fijación al techo + 2 cables de acero + 2 placas de techo con 2 huecos

Panel mit Polyester-Füllmaterial von **unterschiedlicher Dichte** Snowsound® Technology. Polyester-Bezug aus Trevira CS®-Material. Kit aus zwei im Druckgussverfahren hergestellten Lagern aus verchromtem Metall, die das System zur Regelung der Deckenaufhängungskabel verstecken + 2 Stahlseile + 2 Deckenmontageplatten mit 2 Befestigungsbohrungen

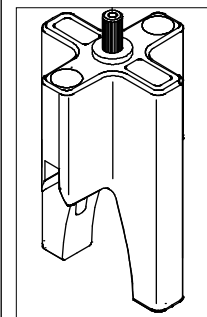

Dettaglio attacco
Support detail





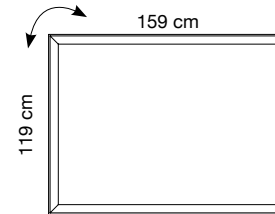
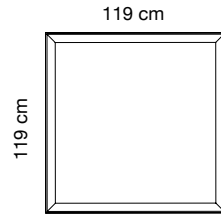

Colore Colour	Codice/Code Prezzo/Price	Codice/Code Prezzo/Price
Bianco White Blanc	0001	701212-0001
Grigio argento Silver grey Gris argenté	8004	701212-8004
Grigio scuro Dark grey Gris foncé	8007	701212-8007
Beige Beige Beige	1008	701212-1008
Tortora Dove-grey Taupe	2005	701212-2005
Giallo Yellow Jaune	3008	701212-3008
Arancione Orange Orange	4030	701212-4030
Rosso Red Rouge	4027	701212-4027
Verde chiaro Light green Vert clair	7004	701212-7004
Mattone Brick red Rouge brique	4086	701212-4086
Azzurro Light blue Bleu clair	6046	701212-6046
Ottanio Teal Sarcelle	6075	701212-6075
Bianco ghiaccio Cool white Blanc glacier	8002	701212-8002

Pannelli con imbottitura interna in poliester a **densità variabile** Snowsound® Technology. Rivestimento esterno in tessuto di poliester Trevira CS®. Completati di struttura posteriore in acciaio zincato e piastra in acciaio zincato per fissaggio a parete.

Panel with polyester internal padding with Snowsound® Technology **variable density**. Polyester covering in Trevira CS® fabric. Complete with galvanized steel back structure and steel plate for wall mounting.

Panneau avec rembourrage interne en polyester à **densité variable** Snowsound® Technology. Revêtement externe en tissu de polyester Trevira CS®. Avec structure postérieure en acier zingué et platine en acier zingué pour la fixation au mur.

Panel con acolchado interior de poliéster de **densidad variable** Snowsound® Technology. Revestimiento exterior en tejido de poliéster Trevira CS®. Completo con estructura de respaldo de acero galvanizado y chapa de acero galvanizado para montaje en pared.

Panel mit Polyester-Füllmaterial von **unterschiedlicher Dichte** Snowsound® Technology. Polyester-Bezug aus Trevira CS®-Material. Mit Rückstruktur aus verzinktem Stahl und verzinkter Stahlplatte ausgestattet zur Befestigung an der Wand.

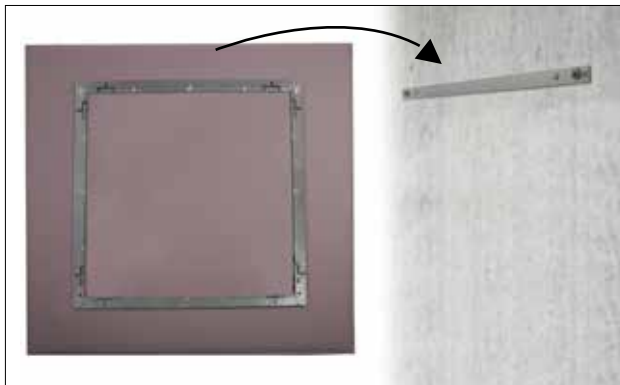
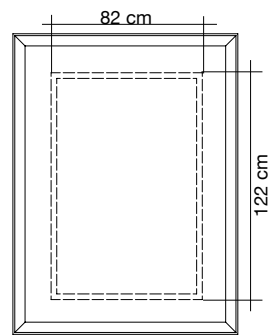
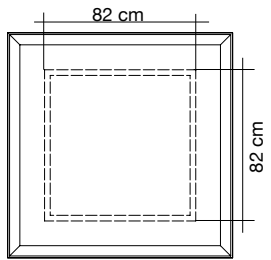

OVERSIZE CEILING

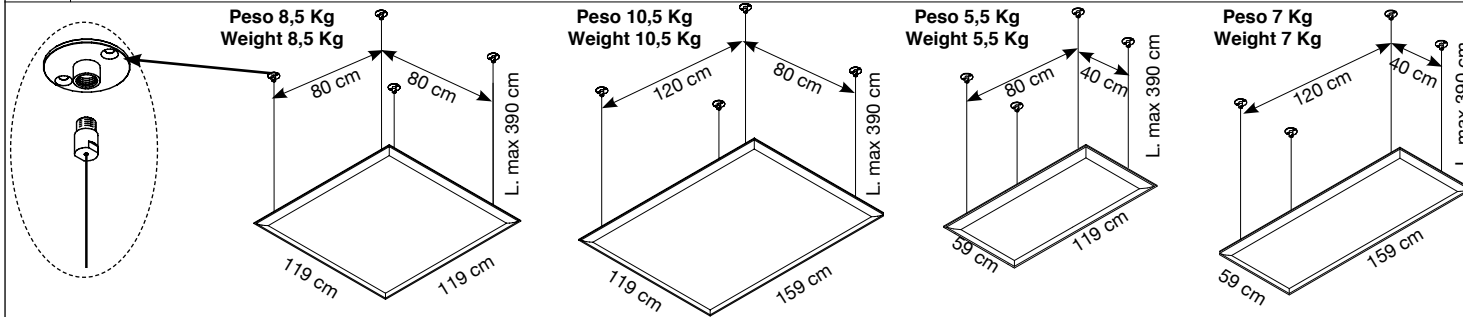

Colore Colour	Codice/Code Prezzo/Price	Codice/Code Prezzo/Price	Codice/Code Prezzo/Price	Codice/Code Prezzo/Price	
Bianco White Blanc	0001	70F1212-0001	70F1216-0001	70F1206-0001	70F1606-0001
Grigio argento Silver grey Gris argenté	8004	70F1212-8004	70F1216-8004	70F1206-8004	70F1606-8004
Grigio scuro Dark grey Gris foncé	8007	70F1212-8007	70F1216-8007	70F1206-8007	70F1606-8007
Beige Beige Beige	1008	70F1212-1008	70F1216-1008	70F1206-1008	70F1606-1008
Tortora Dove-grey Taupe	2005	70F1212-2005	70F1216-2005	70F1206-2005	70F1606-2005
Giallo Yellow Jaune	3008	70F1212-3008	70F1216-3008	70F1206-3008	70F1606-3008

Pannelli con imbottitura interna in poliester a **densità variabile** Snowsound® Technology. Rivestimento esterno in tessuto di poliester Trevira CS®. Completi di struttura in acciaio e kit per fissaggio a soffitto composto da: 4 piastre a soffitto a 2 fori - 4 cavi in acciaio - 4 attacchi per telaio.

Panel with polyester internal padding with Snowsound® Technology **variable density**. Polyester covering in Trevira CS® fabric. Equipped with steelframe and Kit for the ceiling fixing composed of: 4 ceiling plates with 2 holes, 4 steel cables, 4 hangings for frame.

Panneau avec rembourrage interne en polyester à **densité variable** Snowsound® Technology. Revêtement externe en tissu de polyester Trevira CS®. Fourni avec structure en acier et kit d'accrochage au plafond composé de: 4 platines pour plafond à 2 trous - 4 câbles en acier - 4 accrochages pour cadre

Panel con acolchado interior de poliéster de **densidad variable** Snowsound® Technology. Revestimiento exterior en tejido de poliéster Trevira CS®. Completo de estructura de acero y kit para el montaje al techo compuesto por: 4 placas de techo con 2 huecos - 4 cables de acero - 4 enganches para bastidor.

Panel mit Polyester-Füllmaterial von **unterschiedlicher Dichte** Snowsound® Technology. Polyester-Bezug aus Trevira CS®-Material. Ausgestattet mit Gestell aus Stahl und Set für die Deckenbefestigung bestehend aus: 4 Deckenmontageplatten mit 2 Befestigungsbohrungen, 4 Stahlseile, 4 Befestigungen für den Rahmen.

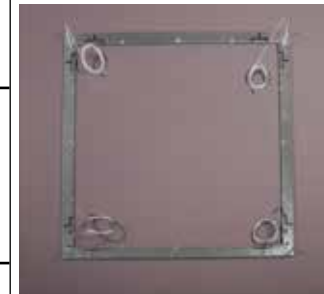

Colore Colour	Codice/Code Prezzo/Price	Codice/Code Prezzo/Price	Codice/Code Prezzo/Price	Codice/Code Prezzo/Price
Arancione Orange Orange 4030	7OF1212-4030	7OF1216-4030	7OF1206-4030	7OF1606-4030
Rosso Red Rouge 4027	7OF1212-4027	7OF1216-4027	7OF1206-4027	7OF1606-4027
Verde chiaro Light green Vert clair 7004	7OF1212-7004	7OF1216-7004	7OF1206-7004	7OF1606-7004
Mattone Brick red Rouge brique 4086	7OF1212-4086	7OF1216-4086	7OF1206-4086	7OF1606-4086
Azzurro Light blue Bleu clair 6046	7OF1212-6046	7OF1216-6046	7OF1206-6046	7OF1606-6046
Ottanio Teal Sarcelle 6075	7OF1212-6075	7OF1216-6075	7OF1206-6075	7OF1606-6075
Bianco ghiaccio Cool white Blanc glacier 8002	7OF1212-8002	7OF1216-8002	7OF1206-8002	7OF1606-8002



OVERSIZE CEILING

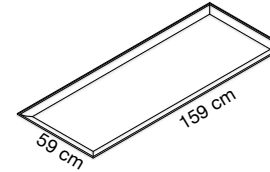
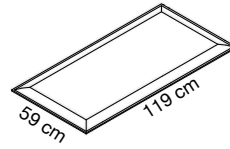
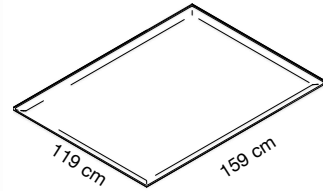
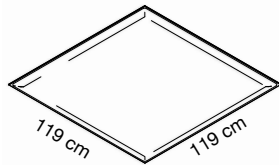
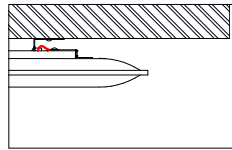

Pannelli con imbottitura interna in poliester a **densità variabile** Snowsound® Technology. Rivestimento esterno in tessuto di poliester Trevira CS®. Completi di struttura in acciaio e kit per fissaggio a soffitto.

Panel with polyester internal padding with Snowsound® Technology **variable density**. Polyester covering in Trevira CS® fabric. Equipped with steelframe and Kit for the ceiling fixing.

Panneau avec rembourrage interne en polyester à **densité variable** Snowsound® Technology. Revêtement externe en tissu de polyester Trevira CS®. Fourni avec structure en acier et kit d'accrochage au plafond.

Panel con acolchado interior de poliéster de **densidad variable** Snowsound® Technology. Revestimiento exterior en tejido de poliéster Trevira CS®. Completo de estructura de acero y kit para el montaje al techo.

Panel mit Polyester-Füllmaterial von **unterschiedlicher Dichte** Snowsound® Technology. Polyester-Bezug aus Trevira CS®-Material. Ausgestattet mit Gestell aus Stahl und Set für die Deckenbefestigung.



Colore Colour	Codice/Code Prezzo/Price	Codice/Code Prezzo/Price	Codice/Code Prezzo/Price	Codice/Code Prezzo/Price
<div style="background-color: #e0e0e0; padding: 2px;">Bianco White Blanc</div> 0001	7OC1212-0001	7OC1216-0001	7OC1206-0001	7OC1606-0001
<div style="background-color: #d0d0d0; padding: 2px;">Grigio argento Silver grey Gris argenté</div> 8004	7OC1212-8004	7OC1216-8004	7OC1206-8004	7OC1606-8004
<div style="background-color: #808080; padding: 2px;">Grigio scuro Dark grey Gris foncé</div> 8007	7OC1212-8007	7OC1216-8007	7OC1206-8007	7OC1606-8007
<div style="background-color: #c0c0c0; padding: 2px;">Beige Beige Beige</div> 1008	7OC1212-1008	7OC1216-1008	7OC1206-1008	7OC1606-1008
<div style="background-color: #808080; padding: 2px;">Tortora Dove-grey Taupe</div> 2005	7OC1212-2005	7OC1216-2005	7OC1206-2005	7OC1606-2005
<div style="background-color: #e0e0e0; padding: 2px;">Giallo Yellow Jaune</div> 3008	7OC1212-3008	7OC1216-3008	7OC1206-3008	7OC1606-3008

Colore Colour	Codice/Code Prezzo/Price	Codice/Code Prezzo/Price	Codice/Code Prezzo/Price	Codice/Code Prezzo/Price
Arancione Orange Orange 4030	7OC1212-4030	7OC1216-4030	7OC1206-4030	7OC1606-4030
Rosso Red Rouge 4027	7OC1212-4027	7OC1216-4027	7OC1206-4027	7OC1606-4027
Verde chiaro Light green Vert clair 7004	7OC1212-7004	7OC1216-7004	7OC1206-7004	7OC1606-7004
Mattone Brick red Rouge brique 4086	7OC1212-4086	7OC1216-4086	7OC1206-4086	7OC1606-4086
Azzurro Light blue Bleu clair 6046	7OC1212-6046	7OC1216-6046	7OC1206-6046	7OC1606-6046
Ottanio Teal Sarcelle 6075	7OC1212-6075	7OC1216-6075	7OC1206-6075	7OC1606-6075
Bianco ghiaccio Cool white Blanc glacier 8002	7OC1212-8002	7OC1216-8002	7OC1206-8002	7OC1606-8002

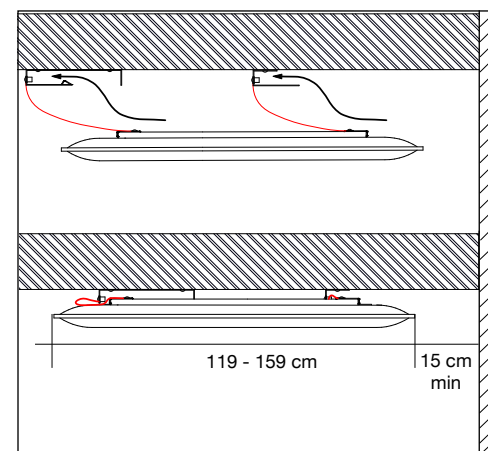
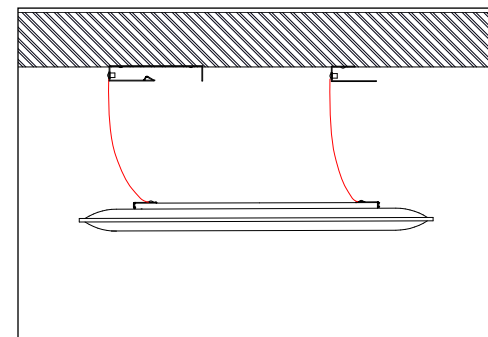
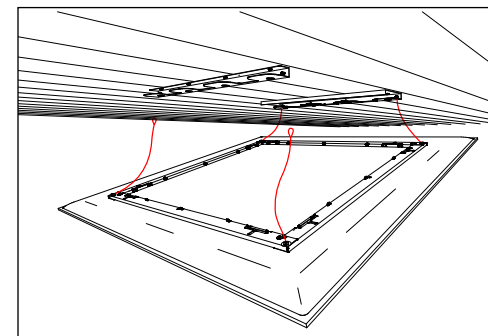

MONTAGGIO / INSTALLATION

Pannello/Panel L. 119 → min. 134 cm

Pannello/Panel L. 159 → min. 174 cm

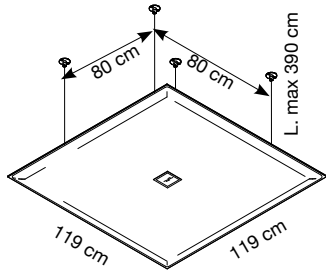

1 per 9,4 W
1 for 9,4 W

Colore Colour	Codice/Code Prezzo/Price
Bianco White Blanc	0001
Grigio argento Silver grey Gris argenté	8004
Grigio scuro Dark grey Gris foncé	8007
Beige Beige Beige	1008
Tortora Dove-grey Taupe	2005
Giallo Yellow Jaune	3008
Arancione Orange Orange	4030
Rosso Red Rouge	4027
Verde chiaro Light green Vert clair	7004
Mattone Brick red Rouge brique	4086
Azzurro Light blue Bleu clair	6046
Ottanio Teal Sarcelle	6075
Bianco ghiaccio Cool white Blanc glacier	8002

Pannelli con imbottitura interna in poliester a **densità variabile** Snowsound® Technology. Rivestimento esterno in tessuto di poliester Trevira CS®. Faretto LED quadrato potenza 9,4W, 3000K, realizzato in metallo verniciato con polveri epossidiche bianco opaco, con schermi diffusori satinati. Completi di struttura in acciaio e kit per fissaggio a soffitto composto da: 4 piastre a soffitto a 2 fori - 4 cavi in acciaio - 4 attacchi per telaio. Cavo di alimentazione L. 390 cm.

OPZIONALE: rosone, vedi pag. 160

Panel with polyester internal padding with Snowsound® Technology **variable density**. Polyester covering in Trevira CS® fabric. 1 square LED spotlight, 9.4W power, 3000K, made of epoxy powder-coated, with satin-finish diffuser shields. Equipped with steelframe and Kit for the ceiling fixing composed of: 4 ceiling plates with 2 holes, 4 steel cables, 4 hangings for frame. Length of power supply cable: 390 cm. **OPTIONAL: ceiling rose, see page. 160**

Panneau avec rembourrage interne en polyester à **densité variable** Snowsound® Technology. Revêtement externe en tissu de polyester Trevira CS®. 1 lumière LED carrée de 9,4W, 3000K, en métal peint en époxy blanc mat, avec écrans diffuseurs satinés. Fourni avec structure en acier et kit d'accrochage au plafond composé de: 4 platines pour plafond à 2 trous - 4 câbles en acier - 4 accrochages pour cadre. Cordon d'alimentation L. 390 cm.

OPTIONNEL: rosace, voir page 160

Panel con acolchado interior de poliéster de **densidad variable** Snowsound® Technology. Revestimiento exterior en tejido de poliéster Trevira CS®. 1 foco LED cuadrados potencia 9,4W, 3000K, de metal barnizado con polvos epoxi blanco opaco, con pantallas difusoras satinadas. Completo de estructura de acero y kit para el montaje al techo compuesto por: 4 placas de techo con 2 huecos - 4 cables de acero - 4 enganches para bastidor. Cable de alimentación L. 390 cm. **OPCIONAL: rosetón, pag. 160**

Panel mit Polyester-Füllmaterial von **unterschiedlicher Dichte** Snowsound® Technology. Polyester-Bezug aus Trevira CS®-Material. 1 viereckige LED-Spots (9,4W, 3000K) aus pulverbeschichtetem mattweiß Metall und mit satinierten Diffusoren. Ausgestattet mit Gestell aus Stahl und Set für die Deckenbefestigung bestehend aus: 4 Deckenmontageplatten mit 2 Befestigungsbohrungen, 4 Stahlseile, 4 Befestigungen für den Rahmen. Netzteil-Länge. 390 cm. **FAKULTATIV: rosette, Seite 160**



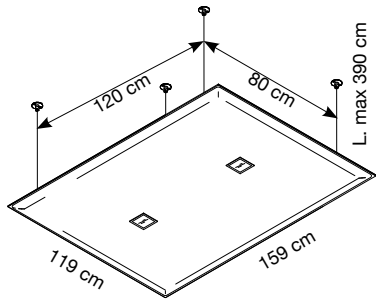

2 per 9,4 W (tot. 18,8 W)
2 for 9,4 W (total 18,8 W)

Colore Colour	Codice/Code Prezzo/Price
Bianco White Blanc	0001
Grigio argento Silver grey Gris argenté	8004
Grigio scuro Dark grey Gris foncé	8007
Beige Beige Beige	1008
Tortora Dove-grey Taupe	2005
Giallo Yellow Jaune	3008
Arancione Orange Orange	4030
Rosso Red Rouge	4027
Verde chiaro Light green Vert clair	7004
Mattone Brick red Rouge brique	4086
Azzurro Light blue Bleu clair	6046
Ottanio Teal Sarcelle	6075
Bianco ghiaccio Cool white Blanc glacier	8002

Pannelli con imbottitura interna in poliester a **densità variabile** Snowsound® Technology. Rivestimento esterno in tessuto di poliester Trevira CS®. 2 faretti LED quadrati potenza 9,4W ciascuno, 3000K, realizzati in metallo verniciato con polveri epossidiche bianco opaco, con schermi diffusori satinati. Completi di struttura in acciaio e kit per fissaggio a soffitto composto da: 4 piastre a soffitto a 2 fori - 4 cavi in acciaio - 4 attacchi per telaio. Cavo di alimentazione L. 390 cm. **OPZIONALE: rosone, vedi pag. 160**

Panel with polyester internal padding with Snowsound® Technology **variable density**. Polyester covering in Trevira CS® fabric. 2 square LED spotlights, 9.4W power each, 3000K, made of epoxy powder-coated, with satin-finish diffuser shields. Equipped with steelframe and Kit for the ceiling fixing composed of: 4 ceiling plates with 2 holes, 4 steel cables, 4 hangings for frame. Length of power supply cable: 390 cm. **OPTIONAL: ceiling rose, see page. 160**

Panneau avec rembourrage interne en polyester à **densité variable** Snowsound® Technology. Revêtement externe en tissu de polyester Trevira CS®. 2 lumières LED carrées de 9,4W chacune, 3000K, en métal peint en époxy blanc mat, avec écrans diffuseurs satinés. Fourni avec structure en acier et kit d'accrochage au plafond composé de: 4 platines pour plafond à 2 trous - 4 câbles en acier - 4 accrochages pour cadre. Cordon d'alimentation L. 390 cm. **OPTIONNEL: rosace, voir page 160.**

Panel con acolchado interior de poliéster de **densidad variable** Snowsound® Technology. Revestimiento exterior en tejido de poliéster Trevira CS®. 2 focos LED cuadrados potencia 9,4W cada uno, 3000K, de metal barnizado con polvos epoxi blanco opaco, con pantallas difusoras satinadas. Completo de estructura de acero y kit para el montaje al techo compuesto por: 4 placas de techo con 2 huecos - 4 cables de acero - 4 enganches para bastidor. Cable de alimentación L. 390 cm. **OPCIONAL: rosetón, pag. 160**

Panel mit Polyester-Füllmaterial von **unterschiedlicher Dichte** Snowsound® Technology. Polyester-Bezug aus Trevira CS®-Material. 2 viereckige LED-Spots (je 9,4W, 3000K) aus pulverbeschichtetem mattweiß Metall und mit satinierten Diffusoren. Ausgestattet mit Gestell aus Stahl und Set für die Deckenbefestigung bestehend aus: 4 Deckenmontageplatten mit 2 Befestigungsbohrungen, 4 Stahlseile, 4 Befestigungen für den Rahmen. Netzteil-Länge. 390 cm. **FAKULTATIV: rosette, Seite 160**

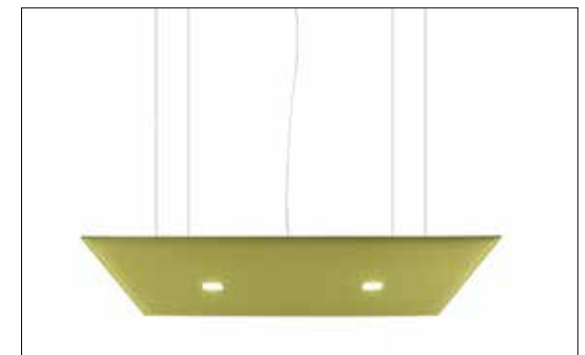

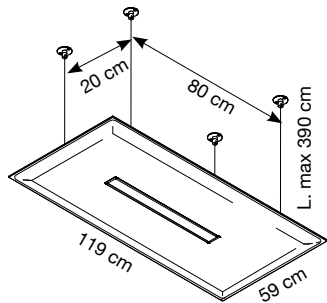

1 per 17,4 W
1 for 17,4 W



OPZIONALE: rosone, vedi pag. 160
Diffusore microprismatico - UGR, vedi pag. 161
OPTIONAL: ceiling rose, see page 160
Microprismatic Diffuser - UGR, see page 161
OPTIONNEL: rosace, voir page 160
Diffuseur microprismatique - UGR, voir page 161
OPCIONAL: rosetón, pag. 160
Difusor Microprismático - UGR, pag. 161
FAKULTATIV: rosette, Seite 160
Microprismatischer Diffusor - UGR, Seite 161

Colore Colour	Codice/Code Prezzo/Price	Codice/Code Prezzo/Price
	NON DIMMERABILE NOT DIMMABLE	DIMMERABILE* DIMMABLE *
Bianco White Blanc 0001	70L1206/L6-0001	70L1206/D6-0001
Grigio argento Silver grey Gris argenté 8004	70L1206/L6-8004	70L1206/D6-8004
Grigio scuro Dark grey Gris foncé 8007	70L1206/L6-8007	70L1206/D6-8007
Beige Beige Beige 1008	70L1206/L6-1008	70L1206/D6-1008
Tortora Dove-grey Taupe 2005	70L1206/L6-2005	70L1206/D6-2005
Giallo Yellow Jaune 3008	70L1206/L6-3008	70L1206/D6-3008
Arancione Orange Orange 4030	70L1206/L6-4030	70L1206/D6-4030
Rosso Red Rouge 4027	70L1206/L6-4027	70L1206/D6-4027
Verde chiaro Light green Vert clair 7004	70L1206/L6-7004	70L1206/D6-7004
Mattone Brick red Rouge brique 4086	70L1206/L6-4086	70L1206/D6-4086
Azzurro Light blue Bleu clair 6046	70L1206/L6-6046	70L1206/D6-6046
Ottanio Teal Sarcelle 6075	70L1206/L6-6075	70L1206/D6-6075
Bianco ghiaccio Cool white Blanc glacier 8002	70L1206/L6-8002	70L1206/D6-8002

Pannelli con imbottitura interna in poliester a **densità variabile** Snowsound® Technology. Rivestimento esterno in tessuto di poliester Trevira CS®. Con lampada LED rettangolare potenza 17,4W, 3000K, struttura realizzata in alluminio verniciato bianco opaco, con schermo diffusore satinato. Completi di struttura in acciaio e kit per fissaggio a soffitto composto da: 4 piastre a soffitto a 2 fori - 4 cavi in acciaio - 4 attacchi per telaio. Cavo di alimentazione L. 390 cm.

Panel with polyester internal padding with Snowsound® Technology **variable density**. Polyester covering in Trevira CS® fabric. Rectangular LED lamp, 17.4W power, 3000K, structure made of matt white epoxy powder-coated aluminium, with satin-finish diffuser screen. Equipped with steel frame and Kit for the ceiling fixing composed of: 4 ceiling plates with 2 holes, 4 steel cables, 4 hangings for frame. Length of power supply cable: 390 cm.

Panneau avec rembourrage interne en polyester à **densité variable** Snowsound® Technology. Revêtement externe en tissu de polyester Trevira CS®. Avec lampe LED rectangulaire de 17,4W, 3000K, structure en aluminium peint blanc mat, avec écran diffuseur satiné. Fourni avec structure en acier et kit d'accrochage au plafond composé de: 4 platines pour plafond à 2 trous - 4 câbles en acier - 4 accrochages pour cadre. Cordon d'alimentation L. 390 cm.

Panel con acolchado interior de poliéster de **densidad variable** Snowsound® Technology. Revestimiento exterior en tejido de poliéster Trevira CS®. Con lámpara LED rectangular potencia 17,4W, 3000K, estructura de aluminio barnizado blanco opaco, con pantalla difusora satinada. Completo de estructura de acero y kit para el montaje al techo compuesto por: 4 placas de techo con 2 huecos - 4 cables de acero - 4 enganches para bastidor. Cable de alimentación L. 390 cm.

Panel mit Polyester-Füllmaterial von **unterschiedlicher Dichte** Snowsound® Technology. Polyester-Bezug aus Trevira CS®-Material. Mit viereckiger LED-Lampe (17,4 W, 3000K) und satiniertem Diffusor ausgestattet und mattweiß beschichtete Aluminium-Struktur. Ausgestattet mit Gestell aus Stahl und Set für die Deckenbefestigung bestehend aus: 4 Deckenmontageplatten mit 2 Befestigungsbohrungen, 4 Stahlseile, 4 Befestigungen für den Rahmen. Netzteil-Länge. 390 cm.

*** DIMMERABILE - DIMMABLE
SWITCH DIM (PUSH) OR DALI**

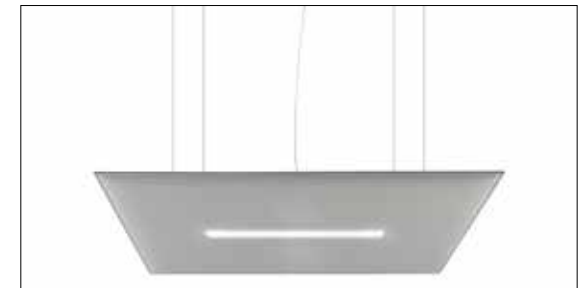

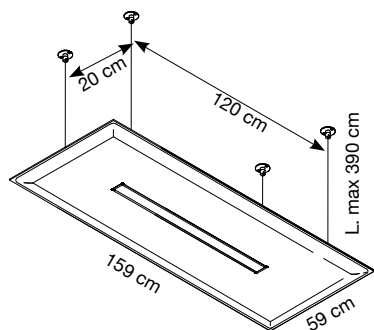













1 per 26,1 W
1 for 26,1 W

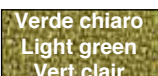

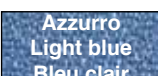
OPZIONALE: rosone, vedi pag. 160
Diffusore microprismatico - UGR, vedi pag. 161
OPTIONAL: ceiling rose, see page 160
Microprismatic Diffuser - UGR, see page 161
OPTIONNEL: rosace, voir page 160
Diffuseur microprismatique - UGR, voir page 161
OPCIONAL: rosetón, pag. 160
Difusor Microprismático - UGR, pag. 161
FAKULTATIV: rosette, Seite 160
Microprismatischer Diffusor - UGR, Seite 161

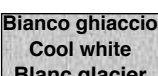
Colore Colour	Colore Colour	Codice/Code Prezzo/Price	Codice/Code Prezzo/Price
		NON DIMMERABILE NOT DIMMABLE	DIMMERABILE* DIMMABLE *
 Bianco White Blanc	0001	7OL1606/L9-0001	7OL1606/D9-0001
 Grigio argento Silver grey Gris argenté	8004	7OL1606/L9-8004	7OL1606/D9-8004
 Grigio scuro Dark grey Gris foncé	8007	7OL1606/L9-8007	7OL1606/D9-8007
 Beige Beige Beige	1008	7OL1606/L9-1008	7OL1606/D9-1008
 Tortora Dove-grey Taupe	2005	7OL1606/L9-2005	7OL1606/D9-2005
 Giallo Yellow Jaune	3008	7OL1606/L9-3008	7OL1606/D9-3008
 Arancione Orange Orange	4030	7OL1606/L9-4030	7OL1606/D9-4030
 Rosso Red Rouge	4027	7OL1606/L9-4027	7OL1606/D9-4027
 Verde chiaro Light green Vert clair	7004	7OL1606/L9-7004	7OL1606/D9-7004
 Mattone Brick red Rouge brique	4086	7OL1606/L9-4086	7OL1606/D9-4086
 Azzurro Light blue Bleu clair	6046	7OL1606/L9-6046	7OL1606/D9-6046
 Ottanio Teal Sarcelle	6075	7OL1606/L9-6075	7OL1606/D9-6075
 Bianco ghiaccio Cool white Blanc glacier	8002	7OL1606/L9-8002	7OL1606/D9-8002

Pannelli con imbottitura interna in poliester a **densità variabile** Snowsound® Technology. Rivestimento esterno in tessuto di poliester Trevira CS®. Con lampada LED rettangolare potenza 26,1W, 3000K, struttura realizzata in alluminio verniciato bianco opaco, con schermo diffusore satinato. Completati di struttura in acciaio e kit per fissaggio a soffitto composto da: 4 piastre a soffitto a 2 fori - 4 cavi in acciaio - 4 attacchi per telaio. Cavo di alimentazione L. 390 cm.

Panel with polyester internal padding with Snowsound® Technology **variable density**. Polyester covering in Trevira CS® fabric. Rectangular LED lamp, 26.1W power, 3000K, structure made of matt white epoxy powder-coated aluminium, with satin-finish diffuser screen. Equipped with steelframe and Kit for the ceiling fixing composed of: 4 ceiling plates with 2 holes, 4 steel cables, 4 hangings for frame. Length of power supply cable: 390 cm.

Panneau avec rembourrage interne en polyester à **densité variable** Snowsound® Technology. Revêtement externe en tissu de polyester Trevira CS®. Avec lampe LED rectangulaire de 26,1W, 3000K, structure en aluminium peint blanc mat, avec écran diffuseur satiné. Fourni avec structure en acier et kit d'accrochage au plafond composé de: 4 platines pour plafond à 2 trous - 4 câbles en acier - 4 accrochages pour cadre. Cordon d'alimentation L. 390 cm.

Panel con acolchado interior de poliéster de **densidad variable** Snowsound® Technology. Revestimiento exterior en tejido de poliéster Trevira CS®. Con lámpara LED rectangular potencia 26,1W, 3000K, estructura de aluminio barnizado blanco opaco, con pantalla difusora satinada. Completo de estructura de acero y kit para el montaje al techo compuesto por: 4 placas de techo con 2 huecos - 4 cables de acero - 4 enganches para bastidor. Cable de alimentación L. 390 cm.

Panel mit Polyester-Füllmaterial von **unterschiedlicher Dichte** Snowsound® Technology. Polyester-Bezug aus Trevira CS®-Material. Mit viereckiger LED-Lampe (26,1W, 3000K) und satiniertem Diffusor ausgestattete und mattweiß beschichtete Aluminium-Struktur. Ausgestattet mit Gestell aus Stahl und Set für die Deckenbefestigung bestehend aus: 4 Deckenmontageplatten mit 2 Befestigungsbohrungen, 4 Stahlseile, 4 Befestigungen für den Rahmen. Netzteil-Länge. 390 cm

*** DIMMERABILE - DIMMABLE
SWITCH DIM (PUSH) OR DALI**

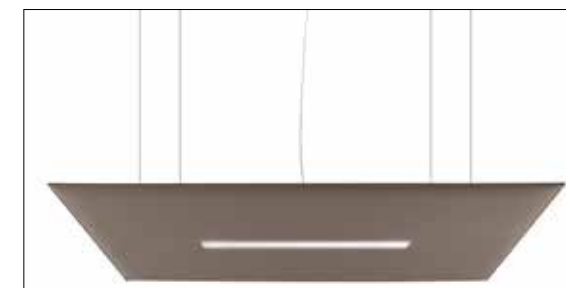

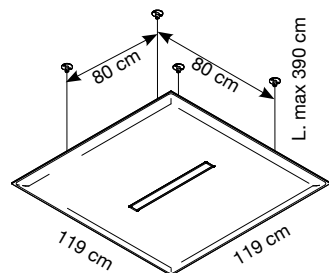

1 per 17,4 W
1 for 17,4 W

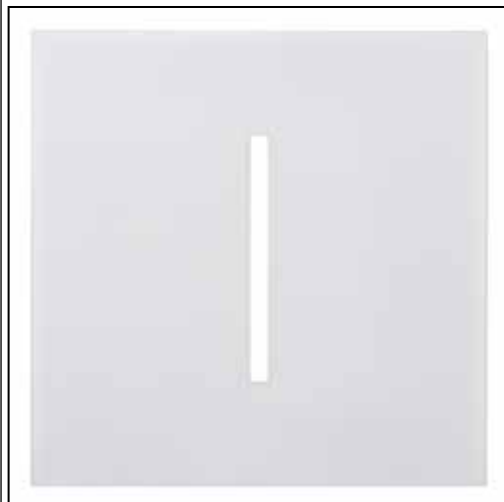

OPZIONALE: rosone, vedi pag. 160
Diffusore microprismatico - UGR, vedi pag. 161
OPTIONAL: ceiling rose, see page 160
Microprismatic Diffuser - UGR, see page 161
OPTIONNEL: rosace, voir page 160
Diffuseur microprismatique - UGR, voir page 161
OPCIONAL: rosetón, pag. 160
Difusor Microprismático - UGR, pag. 161
FAKULTATIV: rosette, Seite 160
Microprismatischer Diffusor - UGR, Seite 161

Colore Colour	Codice/Code Prezzo/Price	Codice/Code Prezzo/Price
	NON DIMMERABILE NOT DIMMABLE	DIMMERABILE* DIMMABLE *
Bianco White Blanc	0001	70L1212/L6-0001
Grigio argento Silver grey Gris argenté	8004	70L1212/L6-8004
Grigio scuro Dark grey Gris foncé	8007	70L1212/L6-8007
Beige Beige Beige	1008	70L1212/L6-1008
Tortora Dove-grey Taupe	2005	70L1212/L6-2005
Giallo Yellow Jaune	3008	70L1212/L6-3008
Arancione Orange Orange	4030	70L1212/L6-4030
Rosso Red Rouge	4027	70L1212/L6-4027
Verde chiaro Light green Vert clair	7004	70L1212/L6-7004
Mattone Brick red Rouge brique	4086	70L1212/L6-4086
Azzurro Light blue Bleu clair	6046	70L1212/L6-6046
Ottanio Teal Sarcelle	6075	70L1212/L6-6075
Bianco ghiaccio Cool white Blanc glacier	8002	70L1212/L6-8002

Pannelli con imbottitura interna in poliester a **densità variabile** Snowsound® Technology. Rivestimento esterno in tessuto di poliester Trevira CS®. Con lampada LED rettangolare potenza 17,4W, 3000K, struttura realizzata in alluminio verniciato bianco opaco, con schermo diffusore satinato. Completi di struttura in acciaio e kit per fissaggio a soffitto composto da: 4 piastre a soffitto a 2 fori - 4 cavi in acciaio - 4 attacchi per telaio. Cavo di alimentazione L. 390 cm.

Panel with polyester internal padding with Snowsound® Technology **variable density**. Polyester covering in Trevira CS® fabric. Rectangular LED lamp, 17.4W power, 3000K, structure made of matt white epoxy powder-coated aluminium, with satin-finish diffuser screen. Equipped with steelframe and Kit for the ceiling fixing composed of: 4 ceiling plates with 2 holes, 4 steel cables, 4 hangings for frame. Length of power supply cable: 390 cm.

Panneau avec rembourrage interne en polyester à **densité variable** Snowsound® Technology. Revêtement externe en tissu de polyester Trevira CS®. Avec lampe LED rectangulaire de 17,4W, 3000K, structure en aluminium peint blanc mat, avec écran diffuseur satiné. Fourni avec structure en acier et kit d'accrochage au plafond composé de: 4 platines pour plafond à 2 trous - 4 câbles en acier - 4 accrochages pour cadre. Cordon d'alimentation L. 390 cm.

Panel con acolchado interior de poliéster de **densidad variable** Snowsound® Technology. Revestimiento exterior en tejido de poliéster Trevira CS®. Con lámpara LED rectangular potencia 17,4W, 3000K, estructura de aluminio barnizado blanco opaco, con pantalla difusora satinada. Completo de estructura de acero y kit para el montaje al techo compuesto por: 4 placas de techo con 2 huecos - 4 cables de acero - 4 enganches para bastidor. Cable de alimentación L. 390 cm.

Panel mit Polyester-Füllmaterial von **unterschiedlicher Dichte** Snowsound® Technology. Polyester-Bezug aus Trevira CS®-Material. Mit viereckiger LED-Lampe (17,4 W, 3000K) und satiniertem Diffusor ausgestattet und mattweiß beschichtete Aluminium-Struktur. Ausgestattet mit Gestell aus Stahl und Set für die Deckenbefestigung bestehend aus: 4 Deckenmontageplatten mit 2 Befestigungsbohrungen, 4 Stahlseile, 4 Befestigungen für den Rahmen. Netzteil-Länge. 390 cm.

*** DIMMERABILE - DIMMABLE
SWITCH DIM (PUSH) OR DALI**

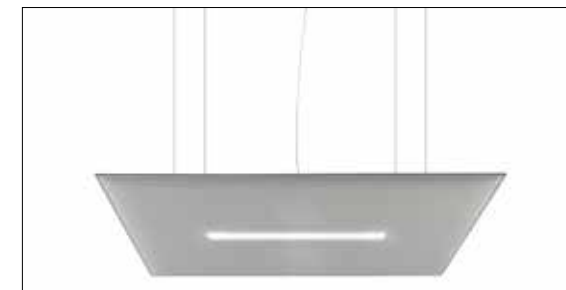

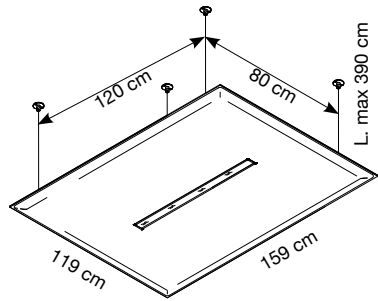

1 per 26,1 W
1 for 26,1 W



OPZIONALE: rosone, vedi pag. 160
Diffusore microprismatico - UGR, vedi pag. 161
OPTIONAL: ceiling rose, see page 160
Microprismatic Diffuser - UGR, see page 161
OPTIONNEL: rosace, voir page 160
Diffuseur microprismatique - UGR, voir page 161
OPCIONAL: rosetón, pag. 160
Difusor Microprismático - UGR, pag. 161
FAKULTATIV: rosette, Seite 160
Microprismatischer Diffusor - UGR, Seite 161

Colore Colour	Codice/Code Prezzo/Price	Codice/Code Prezzo/Price
	NON DIMMERABILE NOT DIMMABLE	DIMMERABILE* DIMMABLE*
Bianco White Blanc	0001 70L1216/L9-0001	70L1216/D9-0001
Grigio argento Silver grey Gris argenté	8004 70L1216/L9-8004	70L1216/D9-8004
Grigio scuro Dark grey Gris foncé	8007 70L1216/L9-8007	70L1216/D9-8007
Beige Beige Beige	1008 70L1216/L9-1008	70L1216/D9-1008
Tortora Dove-grey Taupe	2005 70L1216/L9-2005	70L1216/D9-2005
Giallo Yellow Jaune	3008 70L1216/L9-3008	70L1216/D9-3008
Arancione Orange Orange	4030 70L1216/L9-4030	70L1216/D9-4030
Rosso Red Rouge	4027 70L1216/L9-4027	70L1216/D9-4027
Verde chiaro Light green Vert clair	7004 70L1216/L9-7004	70L1216/D9-7004
Mattone Brick red Rouge brique	4086 70L1216/L9-4086	70L1216/D9-4086
Azzurro Light blue Bleu clair	6046 70L1216/L9-6046	70L1216/D9-6046
Ottanio Teal Sarcelle	6075 70L1216/L9-6075	70L1216/D9-6075
Bianco ghiaccio Cool white Blanc glacier	8002 70L1216/L9-8002	70L1216/D9-8002

Pannelli con imbottitura interna in poliester a **densità variabile** Snowsound® Technology. Rivestimento esterno in tessuto di poliester Trevira CS®. Con lampada LED rettangolare potenza 26,1W, 3000K, struttura realizzata in alluminio verniciato bianco opaco, con schermo diffusore satinato. Completi di struttura in acciaio e kit per fissaggio a soffitto composto da: 4 piastre a soffitto a 2 fori - 4 cavi in acciaio - 4 attacchi per telaio. Cavo di alimentazione L. 390 cm.

Panel with polyester internal padding with Snowsound® Technology **variable density**. Polyester covering in Trevira CS® fabric. Rectangular LED lamp, 26.1W power, 3000K, structure made of matt white epoxy powder-coated aluminium, with satin-finish diffuser screen. Equipped with steelframe and Kit for the ceiling fixing composed of: 4 ceiling plates with 2 holes, 4 steel cables, 4 hangings for frame. Length of power supply cable: 390 cm.

Panneau avec rembourrage interne en polyester à **densité variable** Snowsound® Technology. Revêtement externe en tissu de polyester Trevira CS®. Avec lampe LED rectangulaire de 26,1W, 3000K, structure en aluminium peint blanc mat, avec écran diffuseur satiné. Fourni avec structure en acier et kit d'accrochage au plafond composé de: 4 plaques pour plafond à 2 trous - 4 câbles en acier - 4 accrochages pour cadre. Cordon d'alimentation L. 390 cm.

Panel con acolchado interior de poliéster de **densidad variable** Snowsound® Technology. Revestimiento exterior en tejido de poliéster Trevira CS®. Con lámpara LED rectangular potencia 26,1W, 3000K, estructura de aluminio barnizado blanco opaco, con pantalla difusora satinada. Completo de estructura de acero y kit para el montaje al techo compuesto por: 4 placas de techo con 2 huecos - 4 cables de acero - 4 enganches para bastidor. Cable de alimentación L. 390 cm.

Panel mit Polyester-Füllmaterial von **unterschiedlicher Dichte** Snowsound® Technology. Polyester-Bezug aus Trevira CS®-Material. Mit viereckiger LED-Lampe (26,1W, 3000K) und satiniertem Diffusor ausgestattete und mattweiß beschichtete Aluminium-Struktur. Ausgestattet mit Gestell aus Stahl und Set für die Deckenbefestigung bestehend aus: 4 Deckenmontageplatten mit 2 Befestigungsbohrungen, 4 Stahlseile, 4 Befestigungen für den Rahmen. Netzteil-Länge. 390 cm.

*** DIMMERABILE - DIMMABLE
SWITCH DIM (PUSH) OR DALI**

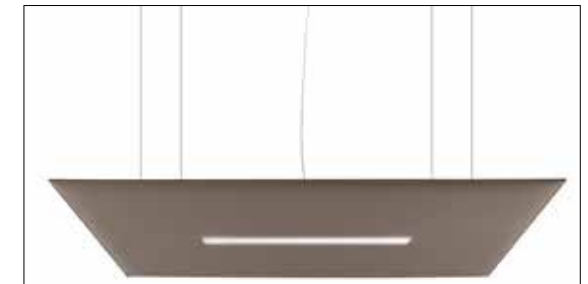

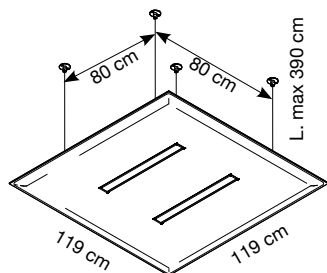

2 per 17,4 W (tot. 34,8)
2 for 17,4 W (total 34,8)

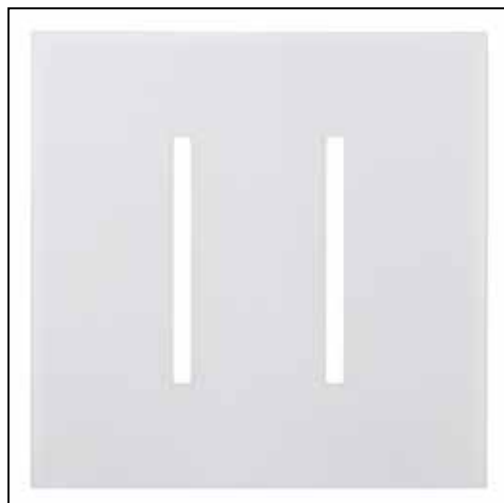

OPZIONALE: rosone, vedi pag. 160
Diffusore microprismatico - UGR, vedi pag. 161
OPTIONAL: ceiling rose, see page 160
Microprismatic Diffuser - UGR, see page 161
OPTIONNEL: rosace, voir page 160
Diffuseur microprismatique - UGR, voir page 161
OPCIONAL: rosetón, pag. 160
Difusor Microprismático - UGR, pag. 161
FAKULTATIV: rosette, Seite 160
Microprismatischer Diffusor - UGR, Seite 161

Colore Colour	Codice/Code Prezzo/Price	Codice/Code Prezzo/Price
	NON DIMMERABILE NOT DIMMABLE	DIMMERABILE * DIMMABLE *
Bianco White Blanc	0001	70L12/2L6-0001
Grigio argento Silver grey Gris argenté	8004	70L12/2L6-8004
Grigio scuro Dark grey Gris foncé	8007	70L12/2L6-8007
Beige Beige Beige	1008	70L12/2L6-1008
Tortora Dove-grey Taupe	2005	70L12/2L6-2005
Giallo Yellow Jaune	3008	70L12/2L6-3008
Arancione Orange Orange	4030	70L12/2L6-4030
Rosso Red Rouge	4027	70L12/2L6-4027
Verde chiaro Light green Vert clair	7004	70L12/2L6-7004
Mattone Brick red Rouge brique	4086	70L12/2L6-4086
Azzurro Light blue Bleu clair	6046	70L12/2L6-6046
Ottanio Teal Sarcelle	6075	70L12/2L6-6075
Bianco ghiaccio Cool white Blanc glacier	8002	70L12/2L6-8002

Pannelli con imbottitura interna in poliester a **densità variabile** Snowsound® Technology. Rivestimento esterno in tessuto di poliester Trevira CS®. Con 2 lampade LED rettangolari potenza 17,4W cad (17,4 W per 2), 3000K, struttura realizzata in alluminio verniciato bianco opaco, con schermo diffusore satinato. Completi di struttura in acciaio e kit per fissaggio a soffitto composto da: 4 piastre a soffitto a 2 fori - 4 cavi in acciaio - 4 attacchi per telaio. 2 cavi di alimentazione L. 390 cm.

Panel with polyester internal padding with Snowsound® Technology **variable density**. Polyester covering in Trevira CS® fabric. 2 Rectangular LED lamps, 17,4 W power each (17,4 W per 2), 3000K, structure made of matt white epoxy powder-coated aluminium, with satin-finish diffuser screen. Equipped with steel frame and Kit for the ceiling fixing composed of: 4 ceiling plates with 2 holes, 4 steel cables, 4 hangings for frame. Length of power supply cables: 390 cm.

Panneau avec rembourrage interne en polyester à **densité variable** Snowsound® Technology. Revêtement externe en tissu de polyester Trevira CS®. Avec 2 lampes LED rectangulaires de 17,4W cad (2 de 17,4 W), 3000K, structure en aluminium peint blanc mat, avec écran diffuseur satiné. Fourni avec structure en acier et kit d'accrochage au plafond composé de: 4 platines pour plafond à 2 trous - 4 câbles en acier - 4 accrochages pour cadre. 2 cordons d'alimentation L. 390 cm.

Panel con acolchado interior de poliéster de **densidad variable** Snowsound® Technology. Revestimiento exterior en tejido de poliéster Trevira CS®. Con 2 lámparas LED rectangulares potencia 17,4W cad (2 de 17,4W), estructura de aluminio barnizado blanco opaco, con pantalla difusora satinada. Completo de estructura de acero y kit para montaje al techo compuesto por: 4 placas de techo con 2 huecos - 4 cables de acero - 4 enganches para bastidor. 2 cables de alimentación L. 390 cm.

Panel mit Polyester-Füllmaterial von **unterschiedlicher Dichte** Snowsound® Technology. Polyester-Bezug aus Trevira CS®-Material. Mit viereckiger LED-Lampe (2 17,4 W, 3000K) und satiniertem Diffusor ausgestattet und mattweiß beschichtete Aluminium-Struktur. Ausgestattet mit Gestell aus Stahl und Set für die Deckenbefestigung bestehend aus: 4 Deckenmontageplatten mit 2 Befestigungsbohrungen, 4 Stahlseile, 4 Befestigungen für den Rahmen. 2 Netzkabel -Länge. 390 cm.

*** DIMMERABILE - DIMMABLE
SWITCH DIM (PUSH) OR DALI**

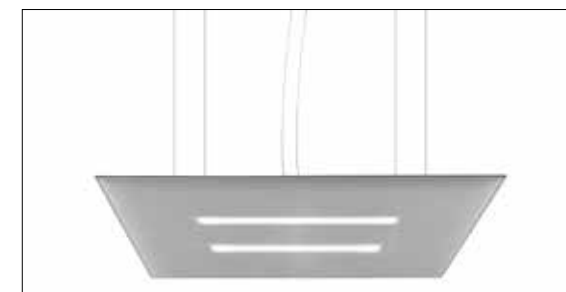

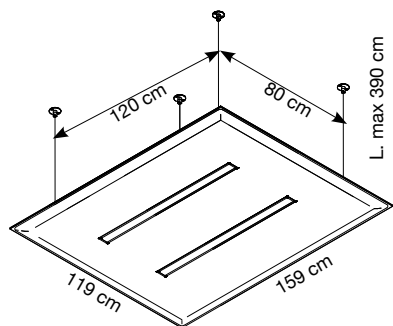

2 per 26,1 W (tot. 52,2 W)
2 for 26,1 W (total 52,2 W)

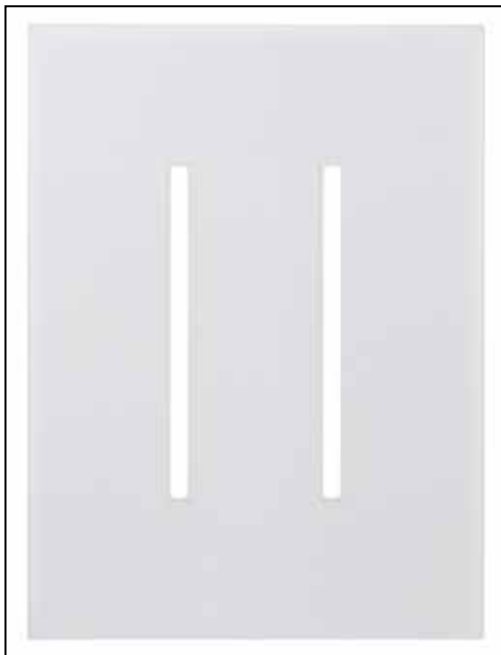

OPZIONALE: rosone, vedi pag. 160
Diffusore microprismatico - UGR, vedi pag. 161
OPTIONAL: ceiling rose, see page 160
Microprismatic Diffuser - UGR, see page 161
OPTIONNEL: rosace, voir page 160
Diffuseur microprismatique - UGR, voir page 161
OPCIONAL: rosetón, pag. 160
Difusor Microprismático - UGR, pag. 161
FAKULTATIV: rosette, Seite 160
Microprismatischer Diffusor - UGR, Seite 161

Colore Colour	Codice/Code Prezzo/Price	Codice/Code Prezzo/Price
	NON DIMMERABILE NOT DIMMABLE	DIMMERABILE * DIMMABLE *
Bianco White Blanc	0001	70L16/2L9-0001
Grigio argento Silver grey Gris argenté	8004	70L16/2L9-8004
Grigio scuro Dark grey Gris foncé	8007	70L16/2L9-8007
Beige Beige Beige	1008	70L16/2L9-1008
Tortora Dove-grey Taupe	2005	70L16/2L9-2005
Giallo Yellow Jaune	3008	70L16/2L9-3008
Arancione Orange Orange	4030	70L16/2L9-4030
Rosso Red Rouge	4027	70L16/2L9-4027
Verde chiaro Light green Vert clair	7004	70L16/2L9-7004
Mattone Brick red Rouge brique	4086	70L16/2L9-4086
Azzurro Light blue Bleu clair	6046	70L16/2L9-6046
Ottanio Teal Sarcelle	6075	70L16/2L9-6075
Bianco ghiaccio Cool white Blanc glacier	8002	70L16/2L9-8002

Pannelli con imbottitura interna in poliester a **densità variabile** Snowsound® Technology. Rivestimento esterno in tessuto di poliester Trevira CS®. Con 2 lampade LED rettangolari potenza 26,1W cad (26,1W per 2), 3000K, struttura realizzata in alluminio verniciato bianco opaco, con schermo diffusore satinato. Completi di struttura in acciaio e kit per fissaggio a soffitto composto da: 4 piastre a soffitto a 2 fori - 4 cavi in acciaio - 4 attacchi per telaio. 2 cavi di alimentazione L. 390 cm.

Panel with polyester internal padding with Snowsound® Technology **variable density**. Polyester covering in Trevira CS® fabric. 2 Rectangular LED lamps, 26.1W power each (26,1 W per 2), 3000K, structure made of matt white epoxy powder-coated aluminium, with satin-finish diffuser screen. Equipped with steelframe and Kit for the ceiling fixing composed of: 4 ceiling plates with 2 holes, 4 steel cables, 4 hangings for frame. Length of power supply cables: 390 cm.

Panneau avec rembourrage interne en polyester à **densité variable** Snowsound® Technology. Revêtement externe en tissu de polyester Trevira CS®. Avec 2 lampes LED rectangulaires de 26,1W cad (2 de 26,1W), 3000K, structure en aluminium peint blanc mat, avec écran diffuseur satiné. Fourni avec structure en acier et kit d'accrochage au plafond composé de: 4 platines pour plafond à 2 trous - 4 câbles en acier - 4 accrochages pour cadre. 2 cordons d'alimentation L. 390 cm.

Panel con acolchado interior de poliéster de **densidad variable** Snowsound® Technology. Revestimiento exterior en tejido de poliéster Trevira CS®. Con 2 lámparas LED rectangulares de 26,1W cad (2 de 26,1W), 3000K, estructura de aluminio barnizado blanco opaco, con pantalla difusora satinada. Completo de estructura de acero y kit para el montaje al techo compuesto por: 4 placas de techo con 2 huecos - 4 cables de acero - 4 enganches para bastidor. 2 cables de alimentación L. 390 cm.

Panel mit Polyester-Füllmaterial von **unterschiedlicher Dichte** Snowsound® Technology. Polyester-Bezug aus Trevira CS®-Material. Mit viereckiger LED-Lampe (2 26,1W, 3000K) und satiniertem Diffusor ausgestattet und mattweiß beschichtete Aluminium-Struktur. Ausgestattet mit Gestell aus Stahl und Set für die Deckenbefestigung bestehend aus: 4 Deckenmontageplatten mit 2 Befestigungsbohrungen, 4 Stahlseile, 4 Befestigungen für den Rahmen. 2 Netzkabel -Länge. 390 cm.

*** DIMMERABILE - DIMMABLE
SWITCH DIM (PUSH) OR DALI**

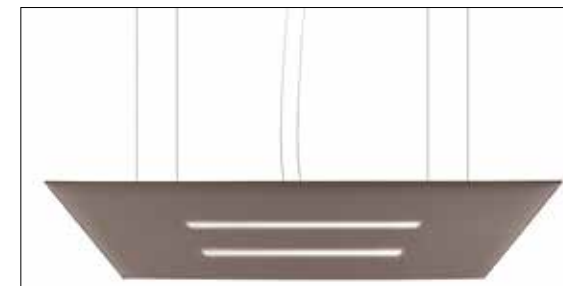

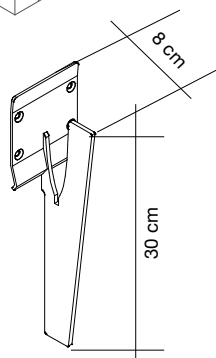
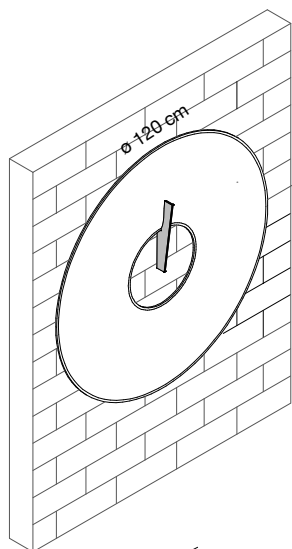

Dettaglio supporto
Fixing detail



Colore
Colour



Bianco
White
Blanc

0001

7GW120NM-0001

7GW120C-0001



Grigio argento
Silver grey
Gris argenté

8004

7GW120NM-8004

7GW120C-8004



Beige
Beige
Beige

1008

7GW120NM-1008

7GW120C-1008



Arancione
Orange
Orange

4030

7GW120NM-4030

7GW120C-4030

Codice/Code
Prezzo/Price



Supporto nero
micaceo
Micaceous black
fixing

Codice/Code
Prezzo/Price



Supporto cromato
Chrome-plated
fixing

Pannelli con imbottitura interna in poliester a **densità variabile** Snowsound® Technology. Rivestimento esterno in tessuto di poliester Trevira CS®. Completi di supporto di fissaggio a parete in acciaio cromato o nero micaceo.

Panel with polyester internal padding with Snowsound® Technology **variable density**. Polyester covering in Trevira CS® fabric. Complete with wall mounting bracket in chrome-plated steel or black micaceous finish.

Panneau avec rembourrage interne en polyester à **densité variable** Snowsound® Technology. Revêtement externe en tissu de polyester Trevira CS®. Fourni avec support pour fixation murale en acier chromé ou noir micacé.

Panel con acolchado interior de poliéster de **densidad variable** Snowsound® Technology. Revestimiento exterior en tejido de poliéster Trevira CS®. Se completa con un soporte de fijación mural de acero cromado o negro mica.

Panel mit Polyester-Füllmaterial von **unterschiedlicher Dichte** Snowsound® Technology. Polyester-Bezug aus Trevira CS®-Material. Inklusive Wandhalterung aus verchromtem oder schwarz schimmerndem Stahl.

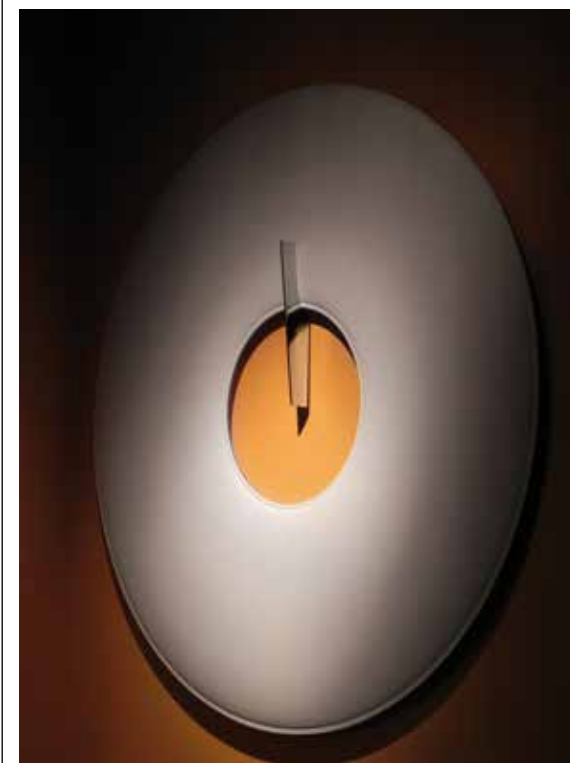

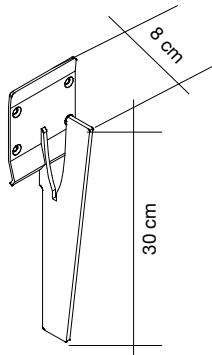
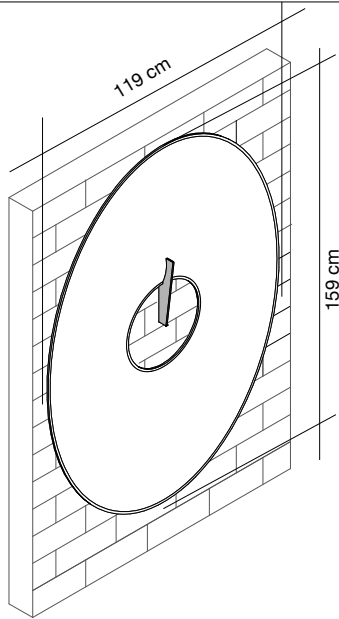

Dettaglio supporto
Fixing detail

Colore
Colour



Bianco
White
Blanc

0001



Grigio argento
Silver grey
Gris argenté

8004



Beige
Beige
Beige

1008



Arancione
Orange
Orange

4030

Codice/Code
Prezzo/Price



Supporto nero
micaceo
Micaceous black
fixing

Codice/Code
Prezzo/Price



Supporto cromato
Chrome-plated
fixing

7GOW/NM-0001

7GOW/C-0001

7GOW/NM-8004

7GOW/C-8004

7GOW/NM-1008

7GOW/C-1008

7GOW/NM-4030

7GOW/C-4030

Pannelli con imbottitura interna in poliester a **densità variabile** Snowsound® Technology. Rivestimento esterno in tessuto di poliester Trevira CS®. Completi di supporto di fissaggio a parete in acciaio cromato o nero micaceo.

Panel with polyester internal padding with Snowsound® Technology **variable density**. Polyester covering in Trevira CS® fabric. Complete with wall mounting bracket in chrome-plated steel or black micaceous finish.

Panneau avec rembourrage interne en polyester à **densité variable** Snowsound® Technology. Revêtement externe en tissu de polyester Trevira CS®. Fourni avec support pour fixation murale en acier chromé ou noir micacé.

Panel con acolchado interior de poliéster de **densidad variable** Snowsound® Technology. Revestimiento exterior en tejido de poliéster Trevira CS®. Se completa con un soporte de fijación mural de acero cromado o negro mica.

Panel mit Polyester-Füllmaterial von **unterschiedlicher Dichte** Snowsound® Technology. Polyester-Bezug aus Trevira CS®-Material. Inklusive Wandhalterung aus verchromtem oder schwarz schimmerndem Stahl



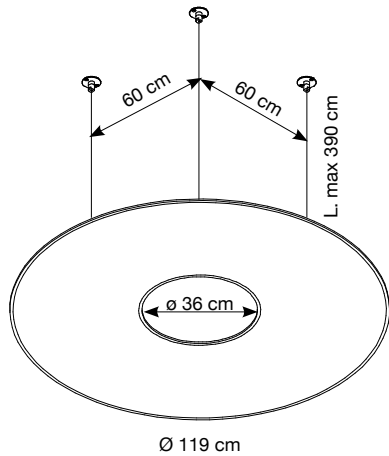

Colore Colour	Codice/Code Prezzo/Price
Bianco White Blanc	0001 7GF120-0001
Grigio argento Silver grey Gris argenté	8004 7GF120-8004
Beige Beige Beige	1008 7GF120-1008
Arancione Orange Orange	4030 7GF120-4030



Pannelli con imbottitura interna in poliester a **densità variabile** Snowsound® Technology. Rivestimento esterno in tessuto di poliester Trevira CS®. Completi di struttura in acciaio e kit per fissaggio a soffitto composto da: 3 piastre a soffitto a 2 fori - 3 cavi in acciaio - 3 attacchi per telaio.

Panel with polyester internal padding with Snowsound® Technology **variable density**. Polyester covering in Trevira CS® fabric. Equipped with steelframe and Kit for the ceiling fixing composed of: 3 ceiling plates with 2 holes, 3 steel cables, 3 hangings for frame.

Panneau avec rembourrage interne en polyester à **densité variable** Snowsound® Technology. Revêtement externe en tissu de polyester Trevira CS®. Fourni avec structure en acier et kit d'accrochage au plafond composé de: 3 platines pour plafond à 2 trous - 3 câbles en acier - 3 accrochages pour cadre

Panel con acolchado interior de poliéster de **densidad variable** Snowsound® Technology. Revestimiento exterior en tejido de poliéster Trevira CS®. Completo de estructura de acero y kit para el montaje al techo compuesto por: 3 placas de techo con 2 huecos - 3 cables de acero - 3 enganches para bastidor.

Panel mit Polyester-Füllmaterial von **unterschiedlicher Dichte** Snowsound® Technology. Polyester-Bezug aus Trevira CS®-Material. Ausgestattet mit Gestell aus Stahl und Set für die Deckenbefestigung bestehend aus: 3 Deckenmontageplatten mit 2 Befestigungsbohrungen, 3 Stahlseile, 3 Befestigungen für den Rahmen. Netzteil-Länge. 390 cm

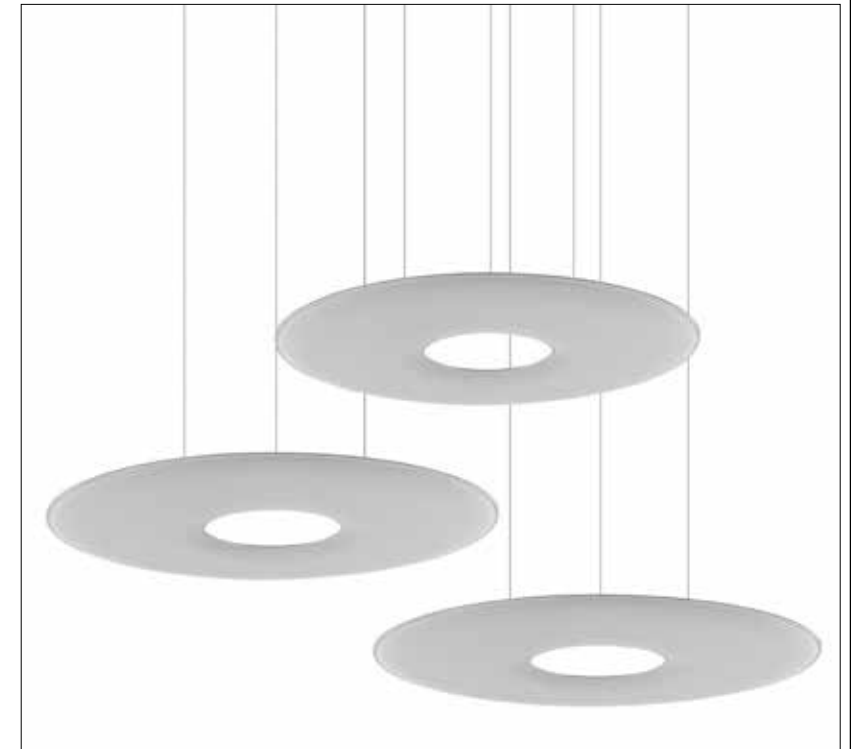

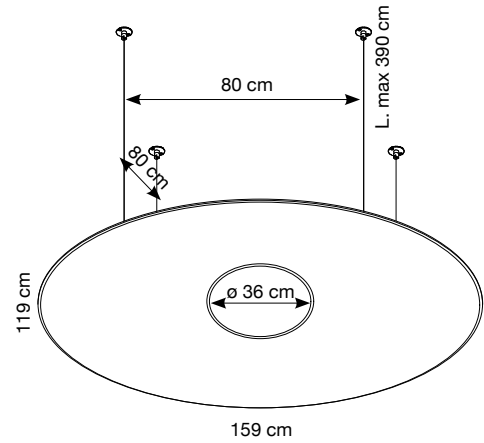

Colore Colour	Codice/Code Prezzo/Price
<p>Bianco White Blanc</p> 	<p>0001 7GOF-0001</p>
<p>Grigio argento Silver grey Gris argenté</p> 	<p>8004 7GOF-8004</p>
<p>Beige Beige Beige</p> 	<p>1008 7GOF-1008</p>
<p>Arancione Orange Orange</p> 	<p>4030 7GOF-4030</p>



Pannelli con imbottitura interna in poliester a **densità variabile** Snowsound® Technology. Rivestimento esterno in tessuto di poliester Trevira CS®. Completi di struttura in acciaio e kit per fissaggio a soffitto composto da: 4 piastre a soffitto a 2 fori - 4 cavi in acciaio - 4 attacchi per telaio.



Panel with polyester internal padding with Snowsound® Technology **variable density**. Polyester covering in Trevira CS® fabric. Equipped with steelframe and Kit for the ceiling fixing composed of: 4 ceiling plates with 2 holes, 4 steel cables, 4 hangings for frame.



Panneau avec rembourrage interne en polyester à **densité variable** Snowsound® Technology. Revêtement externe en tissu de polyester Trevira CS®. Fourni avec structure en acier et kit d'accrochage au plafond composé de: 4 platines pour plafond à 2 trous - 4 câbles en acier - 4 accrochages pour cadre.

Panel con acolchado interior de poliéster de **densidad variable** Snowsound® Technology. Revestimiento exterior en tejido de poliéster Trevira CS®. Completo de estructura de acero y kit para el montaje al techo compuesto por: 4 placas de techo con 2 huecos - 4 cables de acero - 4 enganches para bastidor.

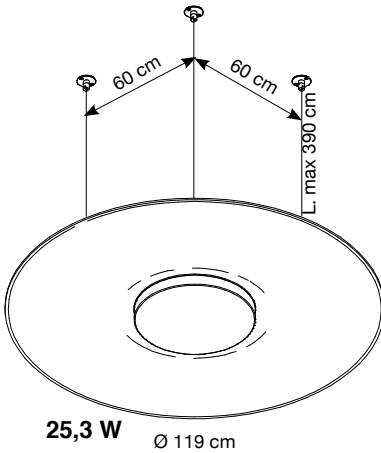
Paneel mit Polyester-Füllmaterial von **unterschiedlicher Dichte** Snowsound® Technology. Polyester-Bezug aus Trevira CS®-Material. Ausgestattet mit Gestell aus Stahl und Set für die Deckenbefestigung bestehend aus: 4 Deckenmontageplatten mit 2 Befestigungsbohrungen, 4 Stahlseile, 4 Befestigungen für den Rahmen. Netzteil-Länge. 390 cm

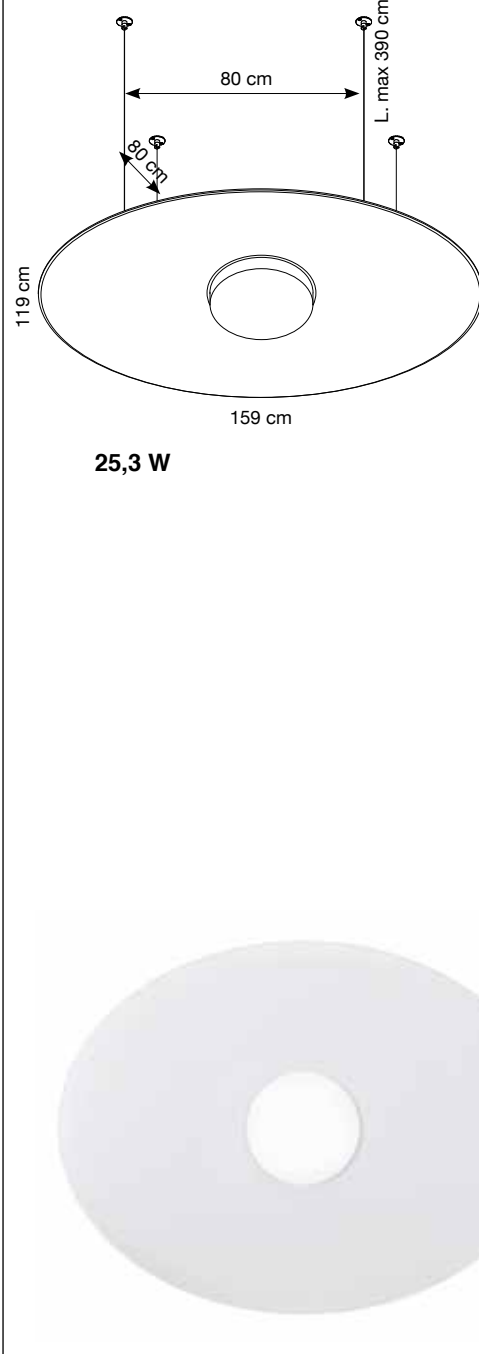

Colore Colour	Codice/Code Prezzo/Price	Codice/Code Prezzo/Price	
 <p>25,3 W Ø 119 cm</p>	<p>NON DIMMERABILE NOT DIMMABLE</p>	<p>DIMMERABILE* DIMMABLE *</p>	<p>Pannelli con imbottitura interna in poliester a densità variabile Snowsound® Technology. Rivestimento esterno in tessuto di poliester Trevira CS®, con corpo illuminante circolare in metallo verniciato con sorgente luminosa a luce LED, potenza 25,3W, 3000K, con diffusore satinato bianco opaco. Completati di struttura in acciaio e kit per fissaggio a soffitto composto da: 3 piastre a soffitto a 2 fori - 3 cavi in acciaio - 3 attacchi per telaio. Cavo di alimentazione L. 390 cm. OPZIONALE: rosone, vedi pag. 160</p> <p>Panel with polyester internal padding with Snowsound® Technology variable density. Polyester covering in Trevira CS® fabric with circular epoxy powder-coated metal illuminating body with LED light source, 25.3W power, 3000K, with matt white satin-finish diffuser. Equipped with steelframe and Kit for the ceiling fixing composed of: 3 ceiling plates with 2 holes, 3 steel cables, 3 hangings for frame. Length of power supply cable: 390 cm. OPTIONAL: ceiling rose, see page. 160</p> <p>Panneau avec rembourrage interne en polyester à densité variable Snowsound® Technology. Revêtement externe en tissu de polyester Trevira CS® avec lampadaire circulaire en métal peint à lampe LED 25,3W, 3000K, diffuseur satiné blanc mat. Fourni avec structure en acier et kit d'accrochage au plafond composé de: 3 platines pour plafond à 2 trous - 3 câbles en acier - 3 accrochages pour cadre. Cordon d'alimentation L. 390 cm. OPTIONNEL: rosace, voir page 160</p> <p>Panel con acolchado interior de poliéster de densidad variable Snowsound® Technology. Revestimiento exterior en tejido de poliéster Trevira CS® con centro iluminante circular de metal barnizado y fuente luminosa de luz LED, potencia 25,3W, 3000K, con difusor satinado blanco opaco. Completo de estructura de acero y kit para el montaje al techo compuesto por: 3 placas de techo con 2 huecos - 3 cables de acero - 3 enganches para bastidor. Cable de alimentación L. 390 cm. OPCIONAL: rosetón, pag. 160</p> <p>Panel mit Polyester-Füllmaterial von unterschiedlicher Dichte Snowsound® Technology. Polyester-Bezug aus Trevira CS®-Material mit rundem Beleuchtungskörper aus beschichtetem Metall und Led-Beleuchtungskörper (25,3W, 3000K), mit mattweißem satiniertem Diffusor. Ausgestattet mit Gestell aus Stahl und Set für die Deckenbefestigung bestehend aus: 3 Deckenmontageplatten mit 2 Befestigungsbohrungen, 3 Stahlseile, 3 Befestigungen für den Rahmen. Netzteil-Länge. 390 cm. FAKULTATIV: rosette, Seite 160</p> <p style="text-align: center;">* DIMMERABILE - DIMMABLE SWITCH DIM (PUSH) OR DALI</p> 
<p>Bianco White Blanc</p> <p>0001</p>	<p>7GL120-0001</p>	<p>7GL120/D-0001</p>	
<p>Grigio argento Silver grey Gris argenté</p> <p>8004</p>	<p>7GL120-8004</p>	<p>7GL120/D-8004</p>	
<p>Beige Beige Beige</p> <p>1008</p>	<p>7GL120-1008</p>	<p>7GL120/D-1008</p>	
<p>Arancione Orange Orange</p> <p>4030</p>	<p>7GL120-4030</p>	<p>7GL120/D-4030</p>	

	Colore Colour	Codice/Code Prezzo/Price	Codice/Code Prezzo/Price	
 <p>119 cm</p> <p>80 cm</p> <p>80 cm</p> <p>L. max 390 cm</p> <p>159 cm</p> <p>25,3 W</p>	<p>Bianco White Blanc</p> <p>0001</p>	<p>NON DIMMERABILE NOT DIMMABLE</p> <p>7GOL-0001</p>	<p>DIMMERABILE * DIMMABLE *</p> <p>7GOL/D-0001</p>	<p>Pannelli con imbottitura interna in poliester a densità variabile Snowsound® Technology. Rivestimento esterno in tessuto di poliester Trevira CS®, con corpo illuminante circolare in metallo verniciato con sorgente luminosa a luce LED, potenza 25,3W, 3000K, con diffusore satinato bianco opaco. Completi di struttura in acciaio e kit per fissaggio a soffitto composto da: 4 piastre a soffitto a 2 fori - 4 cavi in acciaio - 4 attacchi per telaio. Cavo di alimentazione L. 390 cm. OPZIONALE: rosone, vedi pag. 160</p>
	<p>Grigio argento Silver grey Gris argenté</p> <p>8004</p>	<p>7GOL-8004</p>	<p>7GOL/D-8004</p>	<p>Panel with polyester internal padding with Snowsound® Technology variable density. Polyester covering in Trevira CS® fabric with circular epoxy powder-coated metal illuminating body with LED light source, 25.3W power, 3000K, with matt white satin-finish diffuser. Equipped with steelframe and Kit for the ceiling fixing composed of: 4 ceiling plates with 2 holes, 4 steel cables, 4 hangings for frame. Length of power supply cable: 390 cm. OPTIONAL: ceiling rose, see page. 160</p>
	<p>Beige Beige Beige</p> <p>1008</p>	<p>7GOL-1008</p>	<p>7GOL/D-1008</p>	<p>Panneau avec rembourrage interne en polyester à densité variable Snowsound® Technology. Revêtement externe en tissu de polyester Trevira CS® avec lampadaire circulaire en métal peint à lampe LED 25,3W, 3000K, diffuseur satiné blanc mat. Fourni avec structure en acier et kit d'accrochage au plafond composé de: 4 platines pour plafond à 2 trous - 4 câbles en acier - 4 accrochages pour cadre. Cordon d'alimentation L. 390 cm. OPTIONNEL: rosace, voir page 160</p>
	<p>Arancione Orange Orange</p> <p>4030</p>	<p>7GOL-4030</p>	<p>7GOL/D-4030</p>	<p>Panel con acolchado interior de poliéster de densidad variable Snowsound® Technology. Revestimiento exterior en tejido de poliéster Trevira CS® con centro iluminante circular de metal barnizado y fuente luminosa de luz LED, potencia 25,3W, 3000K, con difusor satinado blanco opaco. Completo de estructura de acero y kit para el montaje al techo compuesto por: 4 placas de techo con 2 huecos - 4 cables de acero - 4 enganches para bastidor. Cable de alimentación L. 390 cm. OPCIONAL: rosetón, pag. 160</p>
				<p>* DIMMERABILE - DIMMABLE SWITCH DIM (PUSH) OR DALI</p> 

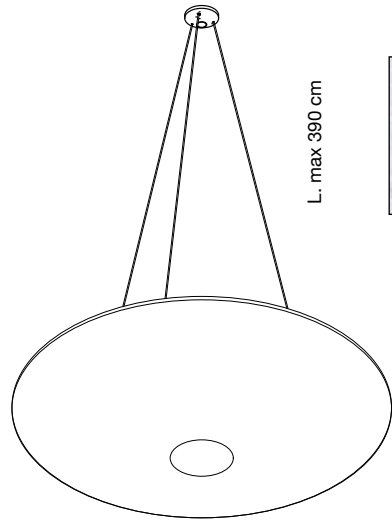

L. max 390 cm

ø 59,5 cm

Colore
Colour

0012

Codice/Code
Prezzo/Price

7TL60-0012

Pannello con imbottitura interna in poliester a **densità variabile** Snowsound® Technology. Rivestimento esterno in tessuto di poliester Trevira CS®. Completo di kit per fissaggio a soffitto composto da: 1 piastra a soffitto - 3 cavi in acciaio - 3 attacchi al pannello.

Panel with polyester internal padding with Snowsound® Technology **variable density**. Polyester covering in Trevira CS® fabric. Equipped with Kit for the ceiling fixing composed of: 1 ceiling plates, 3 steel cables, 3 hangings for panel.

Panneau avec rembourrage interne en polyester à **densité variable** Snowsound® Technology. Revêtement externe en tissu de polyester Trevira CS®. Fourni avec kit d'accrochage au plafond composé de: 1 platine pour plafond – 3 câbles en acier – 3 accrochages au panneau

Panel con acolchado interior de poliéster de **densidad variable** Snowsound® Technology. Revestimiento exterior en tejido de poliéster Trevira CS®. Completo de kit para el montaje al techo compuesto por: 1 placa de techo – 3 cables de acero - 3 enganches al panel.

Paneel mit Polyester-Füllmaterial von **unterschiedlicher Dichte** Snowsound® Technology. Polyester-Bezug aus Trevira CS®-Material. Ausgestattet mit Set für die Deckenbefestigung bestehend aus: 1 Deckenmontageplatten, 3 Stahlseile, 3 Befestigungen für Paneel.



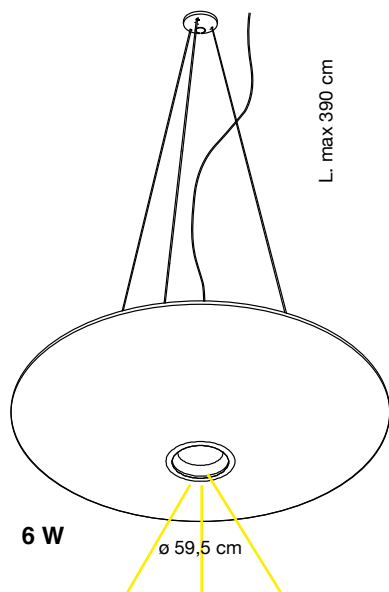

Colore
Colour



0012

Codice/Code
Prezzo/Price

7TLL60/F-0012

Pannello con imbottitura interna in poliester a **densità variabile** Snowsound® Technology, con luce LED, potenza 6 W, 3000K. Rivestimento esterno in tessuto di poliester Trevira CS®. Completo di kit per fissaggio a soffitto composto da: 1 piastra a soffitto - 3 cavi in acciaio - 3 attacchi al pannello. Cavo di alimentazione L. 390 cm.

Panel with polyester internal padding with Snowsound® Technology **variable density**, with LED light source, 6W power, 3000K. Polyester covering in Trevira CS® fabric. Equipped with Kit for the ceiling fixing composed of: 1 ceiling plates, 3 steel cables, 3 hangings for panel. Length of power supply cable: 390 cm.

Panneau avec rembourrage interne en polyester à **densité variable** Snowsound® Technology, avec lampe LED 6W, 3000K. Revêtement externe en tissu de polyester Trevira CS®. Fourni avec kit d'accrochage au plafond composé de: 1 platine pour plafond - 3 câbles en acier - 3 accrochages au panneau. Cordon d'alimentation L. 390 cm.

Panel con acolchado interior de poliéster de **densidad variable** Snowsound® Technology, con fuente luminosa de luz LED, potencia 6W, 3000K. Revestimiento exterior en tejido de poliéster Trevira CS®. Completo de kit para el montaje al techo compuesto por: 1 placa de techo - 3 cables de acero - 3 enganches al panel. Cable de alimentación L. 390 cm.

Panel mit Polyester-Füllmaterial von **unterschiedlicher Dichte** Snowsound® Technology, Led-Beleuchtungskörper (25,3W, 3000K). Polyester-Bezug aus Trevira CS®-Material. Ausgestattet mit Set für die Deckenbefestigung bestehend aus: 1 Deckenmontageplatten, 3 Stahlseile, 3 Befestigungen für Paneel. Netzteil-Länge. 390 cm.



7STL/R-CL

OPZIONALE / OPTIONAL

Rosone cromato per pannelli:
TL LUX 7TLL60/F-0012

Chrome-plated Ceiling rose for panels:
TL LUX 7TLL60/F-0012

Rosace chromé pour panneaux:
TL LUX 7TLL60/F-0012

Rosetón cromado para paneles:
TL LUX 7TLL60/F-0012

Verchromte Rosette für paneele:
TL LUX 7TLL60/F-0012



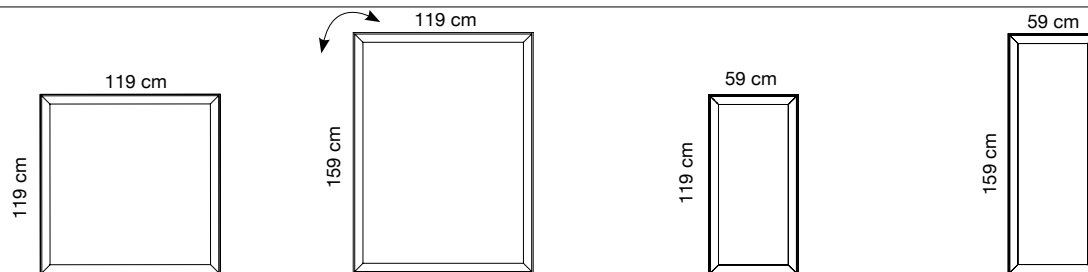

Colore Colour	Codice/Code Prezzo/Price	Codice/Code Prezzo/Price	Codice/Code Prezzo/Price	Codice/Code Prezzo/Price	
Bianco White Blanc	0001	7B1212-0001	7B1216-0001	7B1206-0001	7B1606-0001
Grigio argento Silver grey Gris argenté	8004	7B1212-8004	7B1216-8004	7B1206-8004	7B1606-8004
Grigio scuro Dark grey Gris foncé	8007	7B1212-8007	7B1216-8007	7B1206-8007	7B1606-8007
Beige Beige Beige	1008	7B1212-1008	7B1216-1008	7B1206-1008	7B1606-1008
Tortora Dove-grey Taupe	2005	7B1212-2005	7B1216-2005	7B1206-2005	7B1606-2005
Giallo Yellow Jaune	3008	7B1212-3008	7B1216-3008	7B1206-3008	7B1606-3008
Arancione Orange Orange	4030	7B1212-4030	7B1216-4030	7B1206-4030	7B1606-4030
Rosso Red Rouge	4027	7B1212-4027	7B1216-4027	7B1206-4027	7B1606-4027
Verde chiaro Light green Vert clair	7004	7B1212-7004	7B1216-7004	7B1206-7004	7B1606-7004
Mattone Brick red Rouge brique	4086	7B1212-4086	7B1216-4086	7B1206-4086	7B1606-4086
Azzurro Light blue Bleu clair	6046	7B1212-6046	7B1216-6046	7B1206-6046	7B1606-6046
Ottanio Teal Sarcelle	6075	7B1212-6075	7B1216-6075	7B1206-6075	7B1606-6075
Bianco ghiaccio Cool white Blanc glacier	8002	7B1212-8002	7B1216-8002	7B1206-8002	7B1606-8002

Pannello con imbottitura interna in poliester a **densità variabile** Snowsound® Technology. Rivestimento esterno in tessuto di poliester Trevira CS®.

Panel with polyester internal padding with Snowsound® Technology **variable density**. Polyester covering in Trevira CS® fabric.

Panneau avec rembourrage interne en polyester à **densité variable** Snowsound® Technology. Revêtement externe en tissu de polyester Trevira CS®.

Panel con acolchado interior de poliéster de **densidad variable** Snowsound® Technology. Revestimiento exterior de tejido de poliéster Trevira CS®.

Paneel mit Polyester-Füllmaterial von **unterschiedlicher Dichte** Snowsound® Technology. Polyester-Bezug aus Trevira CS®-Material.

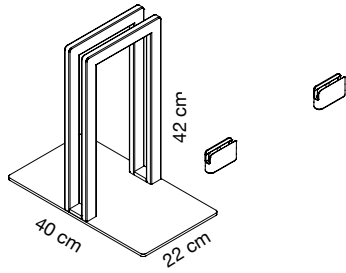

7BB350-GA
Grigio argento
Silver grey
Gris argenté
Gris plata
Silbergrau

Cavalletto in acciaio verniciato con polveri epossidiche completo di piedini di appoggio in tecnopolimero.
Per pannelli Pli Oversize pag. 72.

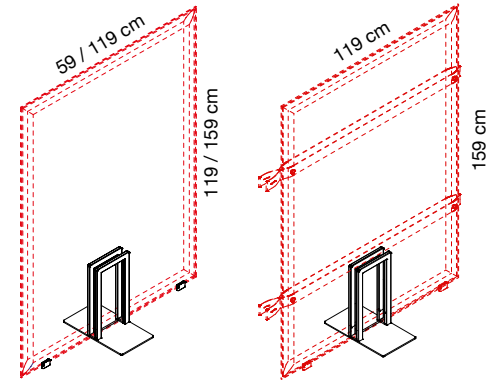

7BB350-BO
Bianco opaco
Mat white
Blanc mat
Blanco mate
Mattweiß

Stand in epoxy powder-coated steel, complete with hi-tech polymer and steel small feet to be applied to the panel.
For Pli Oversize panels page 72.

7BB350-N
Nero opaco
Mat black
Noir mat
Negro mate
Mattschwarz

Chevalet en acier peint en époxy, avec vérins d'appui en technopolymère et acier à appliquer au panneau.
Pour panneaux Pli Oversize page 72.

Soporte de acero pintado en epoxi, completo con patas de apoyo en tecnopolímero y acero para aplicarse al panel.
Para panels Pli Oversize pag. 72.

Standfuß aus pulverbeschichtetem Stahl mit Stützfüßen aus Technopolymer und Stahl, die am Paneel befestigt werden.
Für Pli Oversize Paneele, Seite 72.

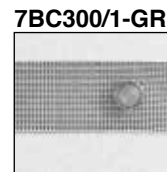
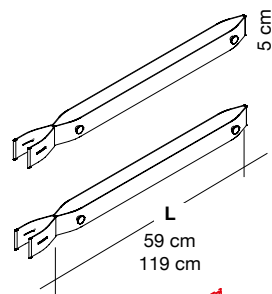

7BC300/1-GR
Per pannelli
For panels
L. 59 cm

Coppia cinghie elastiche in tecnopolimero per pannelli Pli Oversize pag. 72.

Couple of hi-tech polymer elastic straps for Pli Oversize panels page 72.

Paire de sangles élastiques en technopolymère pour panneaux Pli Oversize page 72.

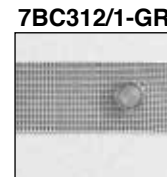
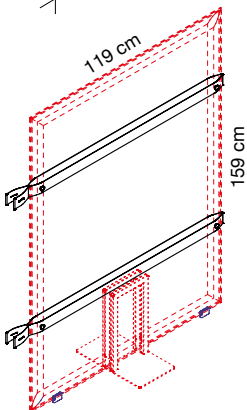

7BC312/1-GR
Per pannelli
For panels
L. 119 cm

Par de correas elásticas en tecnopolímero para panels Pli Oversize pag. 72.

Elastisches Riemen-Paar aus Technopolymer für Pli Oversize Paneele, Seite 72.

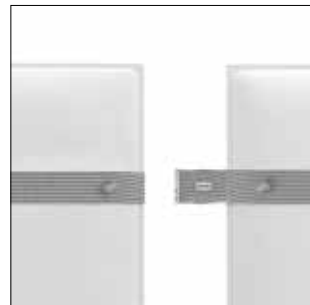

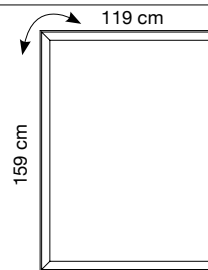
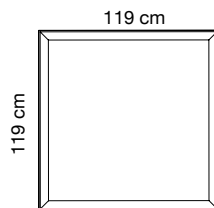

Colore Colour	Codice/Code Prezzo/Price	Codice/Code Prezzo/Price
Bianco White Blanc	0001	7B1212-0001
Grigio argento Silver grey Gris argenté	8004	7B1212-8004
Grigio scuro Dark grey Gris foncé	8007	7B1212-8007
Beige Beige Beige	1008	7B1212-1008
Tortora Dove-grey Taupe	2005	7B1212-2005
Giallo Yellow Jaune	3008	7B1212-3008
Arancione Orange Orange	4030	7B1212-4030
Rosso Red Rouge	4027	7B1212-4027
Verde chiaro Light green Vert clair	7004	7B1212-7004
Mattone Brick red Rouge brique	4086	7B1212-4086
Azzurro Light blue Bleu clair	6046	7B1212-6046
Ottanio Teal Sarcelle	6075	7B1212-6075
Bianco ghiaccio Cool white Blanc glacier	8002	7B1212-8002

Pannello con imbottitura interna in poliestere a **densità variabile** Snowsound® Technology. Rivestimento esterno in tessuto di poliestere Trevira CS®.

Panel with polyester internal padding with Snowsound® Technology **variable density**. Polyester covering in Trevira CS® fabric.

Panneau avec rembourrage interne en polyester à **densité variable** Snowsound® Technology. Revêtement externe en tissu de polyester Trevira CS®.

Panel con acolchado interior de poliéster de **densidad variable** Snowsound® Technology. Revestimiento exterior de tejido de poliéster Trevira CS®.

Paneel mit Polyester-Füllmaterial von **unterschiedlicher Dichte** Snowsound® Technology. Polyester-Bezug aus Trevira CS®-Material.

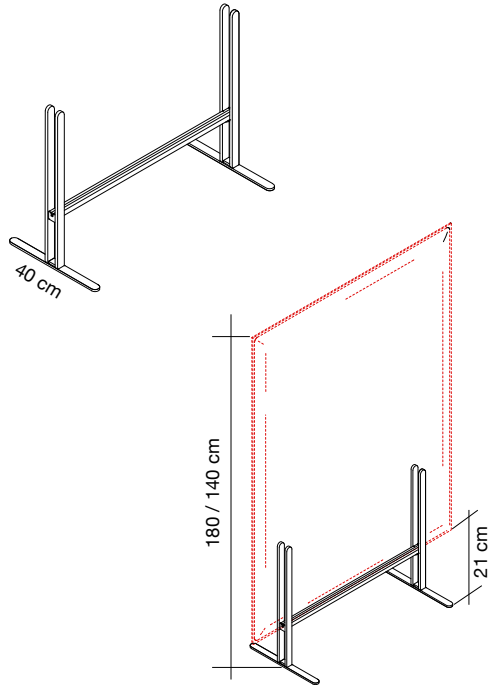

7SBPO-GA
Grigio argento
Silver grey
Gris argenté
Gris plata
Silbergrau

7SBPO-BO
Bianco opaco
Mat white
Blanc mat
Blanco mate
Mattweiß

7SBPO-N
Nero opaco
Mat black
Noir mat
Negro mate
Mattschwarz

Cavalletto in acciaio verniciato con polveri epossidiche.
Per pannelli Pli Over pag. 74.

Easel in epoxy powder-coated steel
For Pli Over panels page 74.

Support en acier peint en époxy
Pour panneaux Pli Over page 74.

Soporte de acero pintado en epoxi
Para panels Pli Over pag. 74.

Standfuß aus pulverbeschichtetem Stahl.
Für Pli Over Paneele, Seite 74.

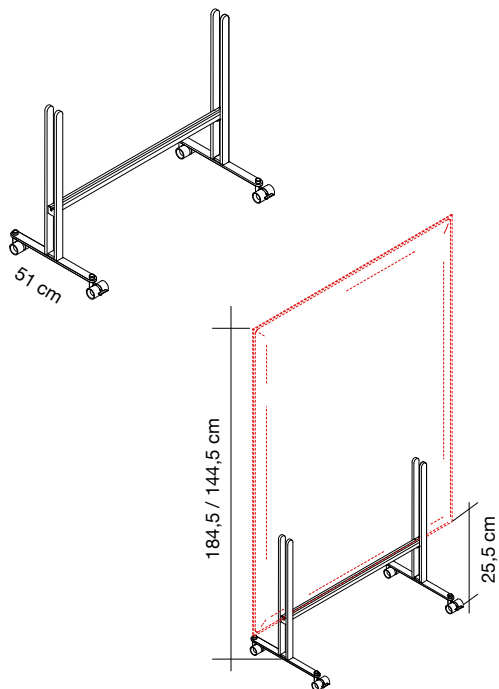
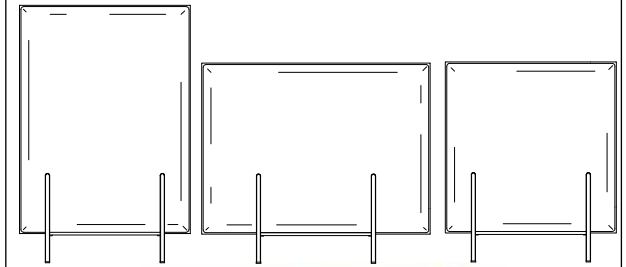

7SBPO/R-GA
Grigio argento
Silver grey
Gris argenté
Gris plata
Silbergrau

7SBPO/R-BO
Bianco opaco
Mat white
Blanc mat
Blanco mate
Mattweiß

7SBPO/R-N
Nero opaco
Mat black
Noir mat
Negro mate
Mattschwarz

Cavalletto in acciaio verniciato con polveri epossidiche,
con ruote in tecnopolimero (2 con freno e 2 senza).
Per pannelli Pli Over pag. 74.

Easel in epoxy powder-coated steel, with high-tech poly-
mer castors (2 with and 2 without brakes).
For Pli Over panels page 74.

Support en acier peint en époxy avec roulettes techno-
polymère (2 avec freins et 2 sans).
Pour panneaux Pli Over page 74.

Soporte de acero pintado en epoxi con ruedas en poli-
mero (2 con freno y 2 sin).
Para panels Pli Over pag. 74.

Standfuß aus pulverbeschichtetem Stahl mit Rollen aus
Technopolymer (2 davon feststellbar).
Für Pli Over Paneele, Seite 74.



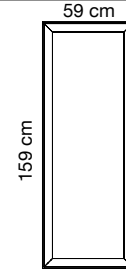
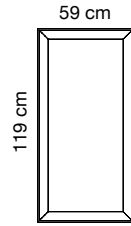

Colore Colour	Codice/Code Prezzo/Price	Codice/Code Prezzo/Price
Bianco White Blanc	0001	7B1206-0001
Grigio argento Silver grey Gris argenté	8004	7B1206-8004
Grigio scuro Dark grey Gris foncé	8007	7B1206-8007
Beige Beige Beige	1008	7B1206-1008
Tortora Dove-grey Taupe	2005	7B1206-2005
Giallo Yellow Jaune	3008	7B1206-3008
Arancione Orange Orange	4030	7B1206-4030
Rosso Red Rouge	4027	7B1206-4027
Verde chiaro Light green Vert clair	7004	7B1206-7004
Mattone Brick red Rouge brique	4086	7B1206-4086
Azzurro Light blue Bleu clair	6046	7B1206-6046
Ottanio Teal Sarcelle	6075	7B1206-6075
Bianco ghiaccio Cool white Blanc glacier	8002	7B1206-8002

Pannello con imbottitura interna in poliester a **densità variabile** Snowsound® Technology. Rivestimento esterno in tessuto di poliester Trevira CS®.

Panel with polyester internal padding with Snowsound® Technology **variable density**. Polyester covering in Trevira CS® fabric.

Panneau avec rembourrage interne en polyester à **densité variable** Snowsound® Technology. Revêtement externe en tissu de polyester Trevira CS®.

Panel con acolchado interior de poliéster de **densidad variable** Snowsound® Technology. Revestimiento exterior de tejido de poliéster Trevira CS®.

Panel mit Polyester-Füllmaterial von **unterschiedlicher Dichte** Snowsound® Technology. Polyester-Bezug aus Trevira CS®-Material.

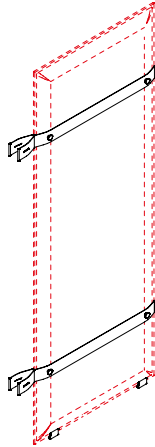
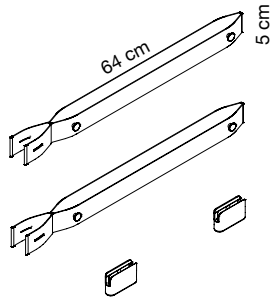

7BC300-N



7BC300-GR

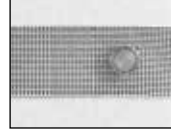

7BC300-BE



Coppia cinghie elastiche in tecnopolimero e piedini di appoggio a terra per pannelli PLI pag. 76.

Pair of elastic hi-tech polymer straps and small support feet for PLI panels page 76.

Paire de sangles élastiques en technopolymère et verins pour appui au sol pour panneaux PLI page 76.

Set de 2 cintas elásticas en tecnopolímero con un pequeño soporte de pie para paneles PLI page 76.

Elastisches Riemen-Paar aus Technopolymer und kleine Standfüße für PLI Paneele Seite 76.



7BB320-C

Cromato
Chrome-plated
Chromé
Cromado
Verchromt

Per pannelli
For panels
L. 59 cm

Cavalletto in acciaio cromato piedini di appoggio a terra per composizioni PLI. Obbligatorio per composizioni in linea o non autoportanti. Per pannelli PLI pag. 76.

Chrome-plated steel stand and small support feet for PLI. Always required for in-line or not self-supporting compositions. For PLI panels page 76.

Chevalet en acier chromé et verins pour appui au sol pour compositions PLI. Obligatoire pour compositions en ligne ou non-autoportantes. Pour panneaux PLI page 76.

Base en acero cromado con un pequeño soporte de pie para composiciones PLI. Siempre para ser colocado en línea o en composiciones que no se soporten por sí solas. Para paneles PLI page 76.

Verchromter Standfuß und kleine Standfüße für PLI. Immer erforderlich für linear aufgestellte bzw. anderweitig nicht hinreichend stabile Zusammenstellungen. Für PLI Paneele Seite 76.

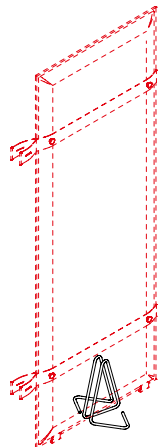
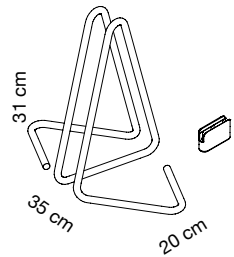

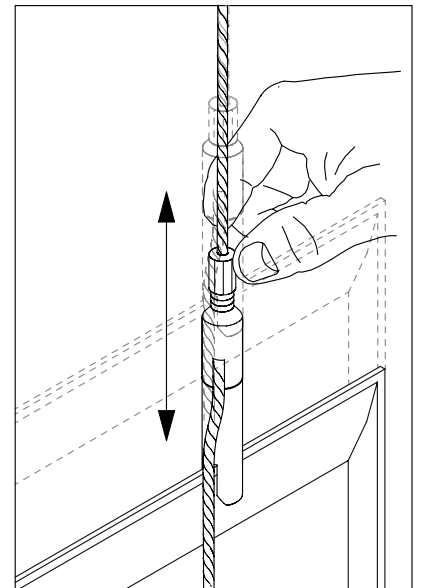

Altezza regolabile
Adjustable height

Pannello con imbottitura interna in poliester a **densità variabile** Snowsound® Technology. Rivestimento esterno in tessuto di poliester Trevira CS®. Completati di kit per fissaggio a soffitto dei pannelli composto da: 2 attacchi a soffitto filettati M6 - 2 cavi in acciaio -2 attacchi per pannello. Il pannello può essere fissato agli attacchi sia verticalmente che orizzontalmente. Gli attacchi si fissano lungo il pannello.

Panel with polyester internal padding with **variable density** Snowsound® Technology. Polyester covering in Trevira CS® fabric. Equipped with kit for the ceiling fixing for panels composed of: 2 ceiling hanging threaded M6, 2 steel cables, 2 hangings for panel. The panel can be clamped at both vertically and horizontally. The brackets are positioned along the panel.

Panneau avec rembourrage interne en polyester à **densité variable** Snowsound® Technology. Revêtement externe en tissu de polyester Trevira CS®. Fourni avec kit d'accrochage au plafond des panneaux composé de: 2 accrochages au plafond filetés M6 – 2 câbles en acier – 2 accrochages pour panneau. Le panneau peut se fixer aux joints en vertical ou horizontal. Les joints se fixent le long du panneau.

Panel con acolchado interior de poliéster de **densidad variable** Snowsound® Technology. Revestimiento exterior en tejido de poliéster Trevira CS®. Completo de kit para el montaje al techo por paneles compuesto por: 2 enganches al techo roscados M6 – 2 cables de acero - 2 enganches para panel. El panel puede ser enganchado tanto en vertical como en horizontal. Los soportes se posicionan a lo largo del panel.

Paneel mit Polyester-Füllmaterial von **unterschiedlicher Dichte** Snowsound® Technology. Polyester-Bezug aus Trevira CS®-Material. Ausgestattet mit Set für die Deckenbefestigung für Paneel bestehend aus: 2 Deckenbefestigungen für Gewinde M6, 2 Stahlseile, 2 Befestigungen für Paneel. Das Paneel kann sowohl vertikal als auch horizontal befestigt werden. Die Halterungen werden entlang des Paneels montiert.

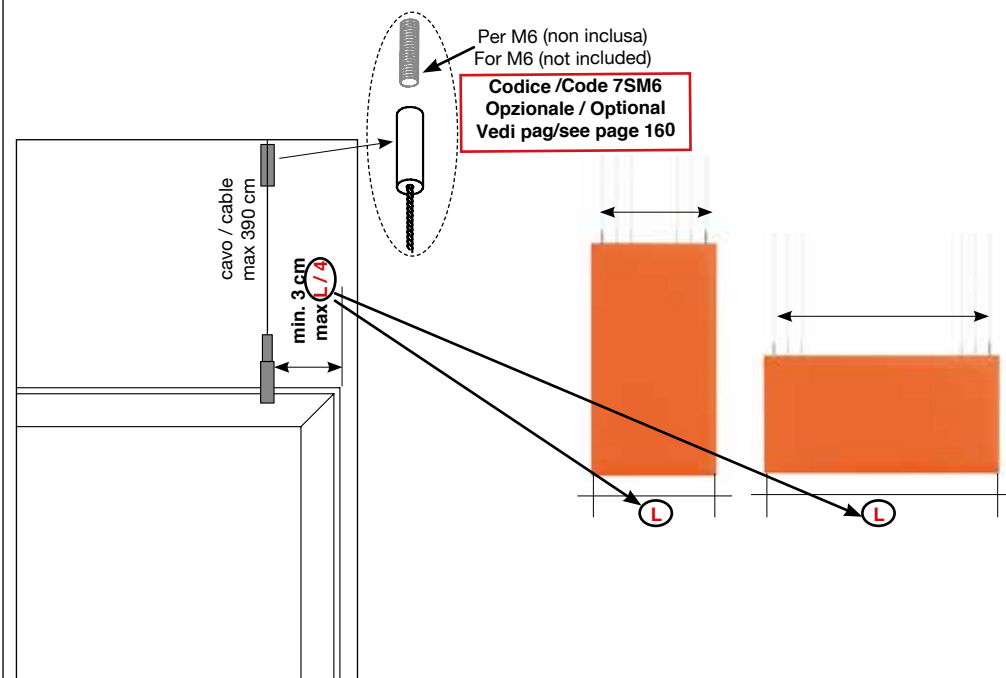

Pannello con imbottitura interna in poliester a **densità variabile** Snowsound® Technology. Rivestimento esterno in tessuto di poliester Trevira CS®. Completati di kit per fissaggio a soffitto dei pannelli composto da: 2 piastre a soffitto a 2 fori - 2 cavi in acciaio -2 attacchi per pannello. Il pannello può essere fissato agli attacchi sia verticalmente che orizzontalmente. Gli attacchi si fissano lungo il pannello.

Panel with polyester internal padding with **variable density** Snowsound® Technology. Polyester covering in Trevira CS® fabric. Equipped with kit for the ceiling fixing for panels composed of: 2 ceiling plates with 2 holes - 2 steel cables - 2 hangings for panel. The panel can be clamped at both vertically and horizontally. The brackets are positioned along the panel.

Panneau avec rembourrage interne en polyester à **densité variable** Snowsound® Technology. Revêtement externe en tissu de polyester Trevira CS®. Fourni avec kit d'accrochage au plafond des panneaux composé de: 2 platines pour plafond à 2 trous – 2 câbles en acier – 2 accrochages pour panneau. Le panneau peut se fixer aux joints en vertical ou horizontal. Les joints se fixent le long du panneau.

Panel con acolchado interior de poliéster de **densidad variable** Snowsound® Technology. Revestimiento exterior en tejido de poliéster Trevira CS®. Completo de kit para el montaje al techo por paneles compuesto por: 2 placas de techo con 2 huecos – 2 cables de acero - 2 enganches para panel. El panel puede ser enganchado tanto en vertical como en horizontal. Los soportes se posicionan a lo largo del panel.

Paneel mit Polyester-Füllmaterial von **unterschiedlicher Dichte** Snowsound® Technology. Polyester-Bezug aus Trevira CS®-Material. Ausgestattet mit Set für die Deckenbefestigung für Paneel bestehend aus: 2 Deckenmontageplatten mit 2 Befestigungsbohrungen - 2 Stahlseile - 2 Befestigungen für Paneel. Das Paneel kann sowohl vertikal als auch horizontal befestigt werden. Die Halterungen werden entlang des Paneels montiert.

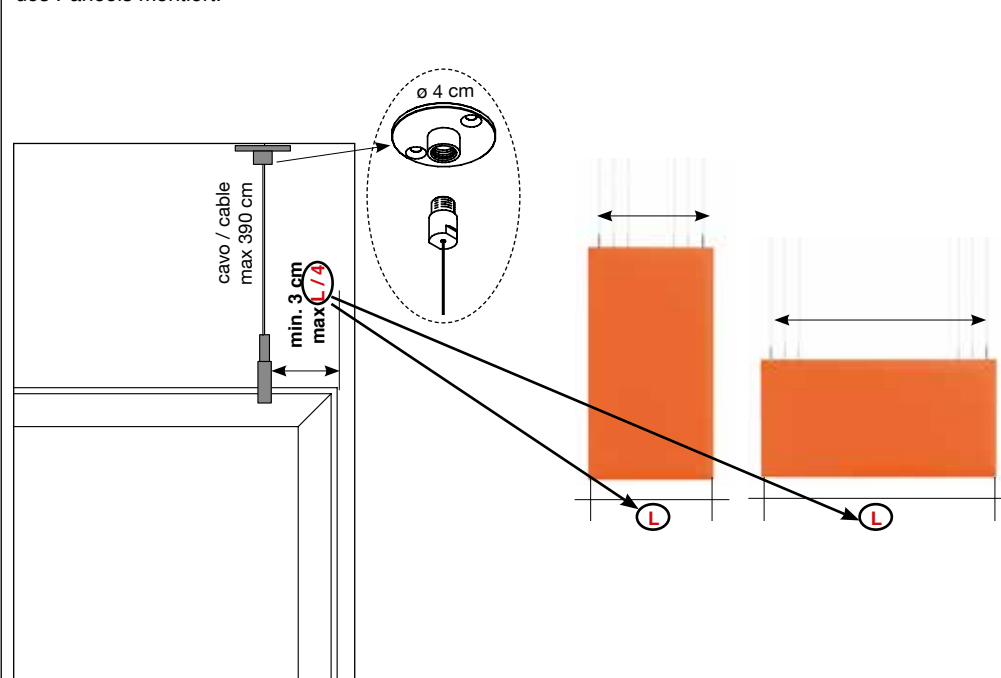

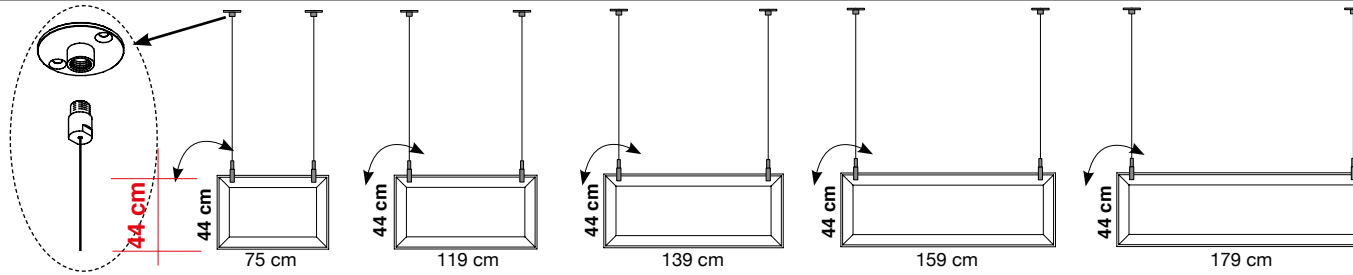

Colore Colour	Codice/Code Prezzo/Price	Codice/Code Prezzo/Price	Codice/Code Prezzo/Price	Codice/Code Prezzo/Price	Codice/Code Prezzo/Price	
Bianco White Blanc	0001	7BF0408-0001	7BF0412-0001	7BF0414-0001	7BF0416-0001	7BF0418-0001
Grigio argento Silver grey Gris argenté	8004	7BF0408-8004	7BF0412-8004	7BF0414-8004	7BF0416-8004	7BF0418-8004
Grigio scuro Dark grey Gris foncé	8007	7BF0408-8007	7BF0412-8007	7BF0414-8007	7BF0416-8007	7BF0418-8007
Beige Beige Beige	1008	7BF0408-1008	7BF0412-1008	7BF0414-1008	7BF0416-1008	7BF0418-1008
Tortora Dove-grey Taupe	2005	7BF0408-2005	7BF0412-2005	7BF0414-2005	7BF0416-2005	7BF0418-2005
Giallo Yellow Jaune	3008	7BF0408-3008	7BF0412-3008	7BF0414-3008	7BF0416-3008	7BF0418-3008
Arancione Orange Orange	4030	7BF0408-4030	7BF0412-4030	7BF0414-4030	7BF0416-4030	7BF0418-4030
Rosso Red Rouge	4027	7BF0408-4027	7BF0412-4027	7BF0414-4027	7BF0416-4027	7BF0418-4027
Verde chiaro Light green Vert clair	7004	7BF0408-7004	7BF0412-7004	7BF0414-7004	7BF0416-7004	7BF0418-7004
Mattone Brick red Rouge brique	4086	7BF0408-4086	7BF0412-4086	7BF0414-4086	7BF0416-4086	7BF0418-4086
Azzurro Light blue Bleu clair	6046	7BF0408-6046	7BF0412-6046	7BF0414-6046	7BF0416-6046	7BF0418-6046
Ottanio Teal Sarcelle	6075	7BF0408-6075	7BF0412-6075	7BF0414-6075	7BF0416-6075	7BF0418-6075

Pannello con imbottitura interna in poliester a **densità variabile** Snowsound® Technology. Rivestimento esterno in tessuto di poliester Trevira CS®.

Panel with polyester internal padding with Snowsound® Technology **variable density**. Polyester covering in Trevira CS® fabric.

Panneau avec rembourrage interne en polyester à **densité variable** Snowsound® Technology. Revêtement externe en tissu de polyester Trevira CS®.

Panel con acolchado interior de poliéster de **densidad variable** Snowsound® Technology. Revestimiento exterior de tejido de poliéster Trevira CS®.

Paneel mit Polyester-Füllmaterial von **unterschiedlicher Dichte** Snowsound® Technology. Polyester-Bezug aus Trevira CS®-Material.

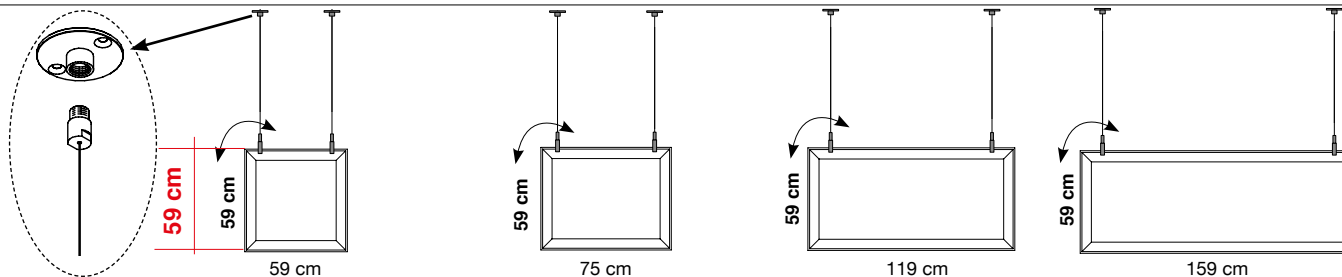

Colore Colour	Codice/Code Prezzo/Price	Codice/Code Prezzo/Price	Codice/Code Prezzo/Price	Codice/Code Prezzo/Price	
Bianco White Blanc	0001	7BF0606-0001	7BF0806-0001	7BF1206-0001	7BF1606-0001
Grigio argento Silver grey Gris argenté	8004	7BF0606-8004	7BF0806-8004	7BF1206-8004	7BF1606-8004
Grigio scuro Dark grey Gris foncé	8007	7BF0606-8007	7BF0806-8007	7BF1206-8007	7BF1606-8007
Beige Beige Beige	1008	7BF0606-1008	7BF0806-1008	7BF1206-1008	7BF1606-1008
Tortora Dove-grey Taupe	2005	7BF0606-2005	7BF0806-2005	7BF1206-2005	7BF1606-2005
Giallo Yellow Jaune	3008	7BF0606-3008	7BF0806-3008	7BF1206-3008	7BF1606-3008
Arancione Orange Orange	4030	7BF0606-4030	7BF0806-4030	7BF1206-4030	7BF1606-4030
Rosso Red Rouge	4027	7BF0606-4027	7BF0806-4027	7BF1206-4027	7BF1606-4027
Verde chiaro Light green Vert clair	7004	7BF0606-7004	7BF0806-7004	7BF1206-7004	7BF1606-7004
Mattone Brick red Rouge brique	4086	7BF0606-4086	7BF0806-4086	7BF1206-4086	7BF1606-4086
Azzurro Light blue Bleu clair	6046	7BF0606-6046	7BF0806-6046	7BF1206-6046	7BF1606-6046
Ottanio Teal Sarcelle	6075	7BF0606-6075	7BF0806-6075	7BF1206-6075	7BF1606-6075
Bianco ghiaccio Cool white Blanc glacier	8002	—————	—————	7BF1206-8002	7BF1606-8002

Pannello con imbottitura interna in poliester a **densità variabile** Snowsound® Technology. Rivestimento esterno in tessuto di poliester Trevira CS®.

Panel with polyester internal padding with Snowsound® Technology **variable density**. Polyester covering in Trevira CS® fabric.

Panneau avec rembourrage interne en polyester à **densité variable** Snowsound® Technology. Revêtement externe en tissu de polyester Trevira CS®.

Panel con acolchado interior de poliéster de **densidad variable** Snowsound® Technology. Revestimiento exterior de tejido de poliéster Trevira CS®.

Paneel mit Polyester-Füllmaterial von **unterschiedlicher Dichte** Snowsound® Technology. Polyester-Bezug aus Trevira CS®-Material.

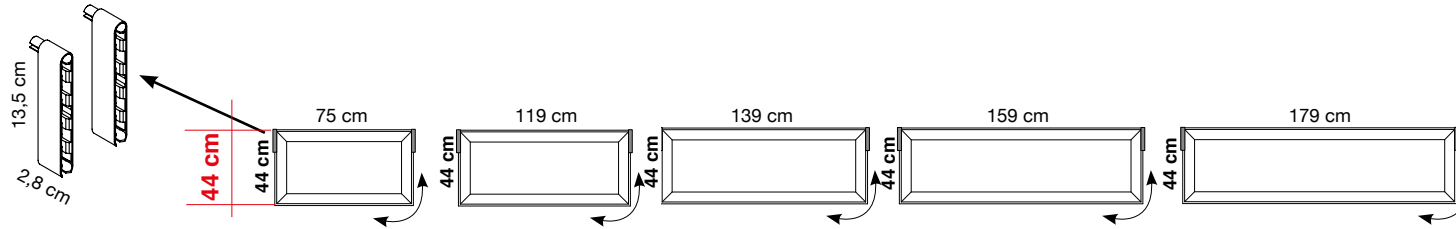

Colore Colour	Codice/Code Prezzo/Price	Codice/Code Prezzo/Price	Codice/Code Prezzo/Price	Codice/Code Prezzo/Price	Codice/Code Prezzo/Price	
Bianco White Blanc	0001	7BTL0408-0001	7BTL0412-0001	7BTL0414-0001	7BTL0416-0001	7BTL0418-0001
Grigio argento Silver grey Gris argenté	8004	7BTL0408-8004	7BTL0412-8004	7BTL0414-8004	7BTL0416-8004	7BTL0418-8004
Grigio scuro Dark grey Gris foncé	8007	7BTL0408-8007	7BTL0412-8007	7BTL0414-8007	7BTL0416-8007	7BTL0418-8007
Beige Beige Beige	1008	7BTL0408-1008	7BTL0412-1008	7BTL0414-1008	7BTL0416-1008	7BTL0418-1008
Tortora Dove-grey Taupe	2005	7BTL0408-2005	7BTL0412-2005	7BTL0414-2005	7BTL0416-2005	7BTL0418-2005
Giallo Yellow Jaune	3008	7BTL0408-3008	7BTL0412-3008	7BTL0414-3008	7BTL0416-3008	7BTL0418-3008
Arancione Orange Orange	4030	7BTL0408-4030	7BTL0412-4030	7BTL0414-4030	7BTL0416-4030	7BTL0418-4030
Rosso Red Rouge	4027	7BTL0408-4027	7BTL0412-4027	7BTL0414-4027	7BTL0416-4027	7BTL0418-4027
Verde chiaro Light green Vert clair	7004	7BTL0408-7004	7BTL0412-7004	7BTL0414-7004	7BTL0416-7004	7BTL0418-7004
Mattone Brick red Rouge brique	4086	7BTL0408-4086	7BTL0412-4086	7BTL0414-4086	7BTL0416-4086	7BTL0418-4086
Azzurro Light blue Bleu clair	6046	7BTL0408-6046	7BTL0412-6046	7BTL0414-6046	7BTL0416-6046	7BTL0418-6046
Ottanio Teal Sarcelle	6075	7BTL0408-6075	7BTL0412-6075	7BTL0414-6075	7BTL0416-6075	7BTL0418-6075

Pannello con imbottitura interna in poliester a **densità variabile** Snowsound® Technology. Rivestimento esterno in tessuto di poliester Trevira CS®. Attacchi cromati.

Panel with polyester internal padding with Snowsound® Technology **variable density**. Polyester covering in Trevira CS® fabric. Chrome-plated connections.

Panneau avec rembourrage interne en polyester à **densité variable** Snowsound® Technology. Revêtement externe en tissu de polyester Trevira CS®. Jonctions chromées.

Panel con acolchado interior de poliéster de **densidad variable** Snowsound® Technology. Revestimiento exterior de tejido de poliéster Trevira CS®. Enganches cromados

Paneel mit Polyester-Füllmaterial von **unterschiedlicher Dichte** Snowsound® Technology. Polyester-Bezug aus Trevira CS®-Material. Verchromte Verbindungen.

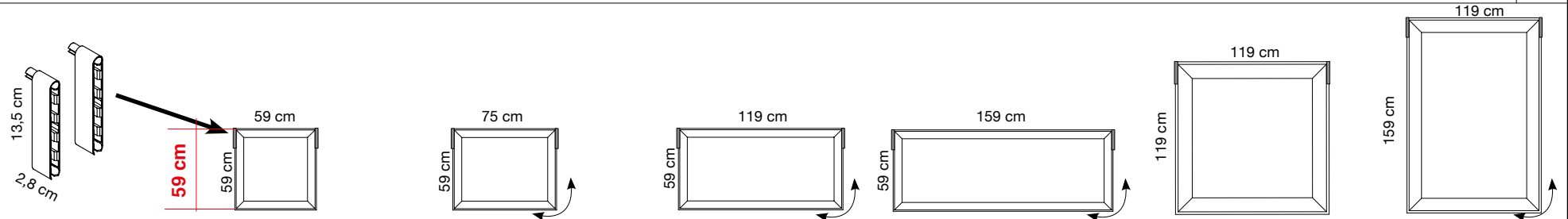

Colore Colour	Codice/Code Prezzo/Price	Codice/Code Prezzo/Price	Codice/Code Prezzo/Price	Codice/Code Prezzo/Price	Codice/Code Prezzo/Price	Codice/Code Prezzo/Price	
Bianco White Blanc	0001	7BTL0606-0001	7BTL0806-0001	7BTL1206-0001	7BTL1606-0001	7BTL1212-0001	7BTL1216-0001
Grigio argento Silver grey Gris argenté	8004	7BTL0606-8004	7BTL0806-8004	7BTL1206-8004	7BTL1606-8004	7BTL1212-8004	7BTL1216-8004
Grigio scuro Dark grey Gris foncé	8007	7BTL0606-8007	7BTL0806-8007	7BTL1206-8007	7BTL1606-8007	7BTL1212-8007	7BTL1216-8007
Beige Beige Beige	1008	7BTL0606-1008	7BTL0806-1008	7BTL1206-1008	7BTL1606-1008	7BTL1212-1008	7BTL1216-1008
Tortora Dove-grey Taupe	2005	7BTL0606-2005	7BTL0806-2005	7BTL1206-2005	7BTL1606-2005	7BTL1212-2005	7BTL1216-2005
Giallo Yellow Jaune	3008	7BTL0606-3008	7BTL0806-3008	7BTL1206-3008	7BTL1606-3008	7BTL1212-3008	7BTL1216-3008
Arancione Orange Orange	4030	7BTL0606-4030	7BTL0806-4030	7BTL1206-4030	7BTL1606-4030	7BTL1212-4030	7BTL1216-4030
Rosso Red Rouge	4027	7BTL0606-4027	7BTL0806-4027	7BTL1206-4027	7BTL1606-4027	7BTL1212-4027	7BTL1216-4027
Verde chiaro Light green Vert clair	7004	7BTL0606-7004	7BTL0806-7004	7BTL1206-7004	7BTL1606-7004	7BTL1212-7004	7BTL1216-7004
Mattone Brick red Rouge brique	4086	7BTL0606-4086	7BTL0806-4086	7BTL1206-4086	7BTL1606-4086	7BTL1212-4086	7BTL1216-4086
Azzurro Light blue Bleu clair	6046	7BTL0606-6046	7BTL0806-6046	7BTL1206-6046	7BTL1606-6046	7BTL1212-6046	7BTL1216-6046
Ottanio Teal Sarcelle	6075	7BTL0606-6075	7BTL0806-6075	7BTL1206-6075	7BTL1606-6075	7BTL1212-6075	7BTL1216-6075
Bianco ghiaccio Cool white Blanc glacier	8002	—	—	7BTL1206-8002	7BTL1606-8002	7BTL1212-8002	7BTL1216-8002

7BTL300

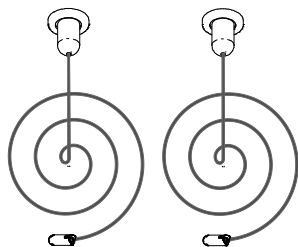

Coppia cavi in acciaio L. 4 m. Piastre a soffitto a 1 foro e terminale inferiore.

Pair of steel cables 4 m. Ceiling plate with 1 hole and lower terminal.

Paire de câbles en acier L. 4 m. Platinas pour plafond à 1 trou et extrémité inférieure.

Set de 2 cables en acero de 4 m. Placas de techo con 1 hueco y extremo inferior.

Ein Paar Stahlseile 4 m. Deckenmontageplatten mit 1 Befestigungsbohrung und unterem Abschlussstück.

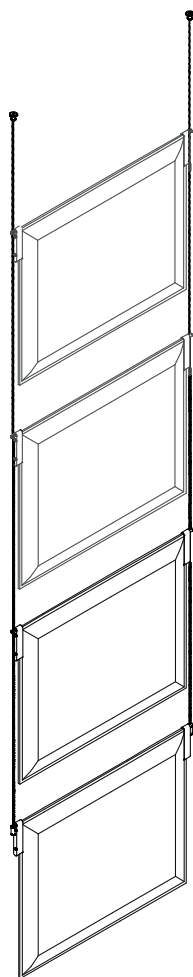

Max 4 pcs for codes

7BTL0408-XXXX (44 x 75cm)
 7BTL0412-XXXX (44 x 119cm)
 7BTL0414-XXXX (44 x 139cm)
 7BTL0416-XXXX (44 x 159cm)
 7BTL0418-XXXX (44 x 179cm)
 7BTL0606-XXXX (59 x 59cm)
 7BTL0806-XXXX (59 x 75cm)
 7BTL1206-XXXX (59 x 119cm)
 7BTL1606-XXXX (59 x 159cm)

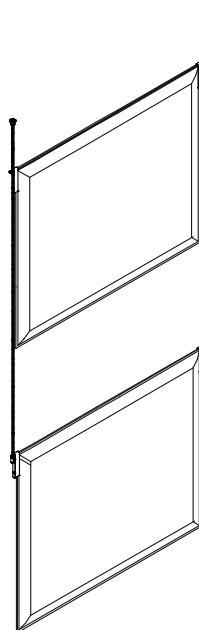

Max 2 pcs for codes

7BTL1212-XXXX (119 x 119cm)
 7BTL1216-XXXX (159 x 119cm)





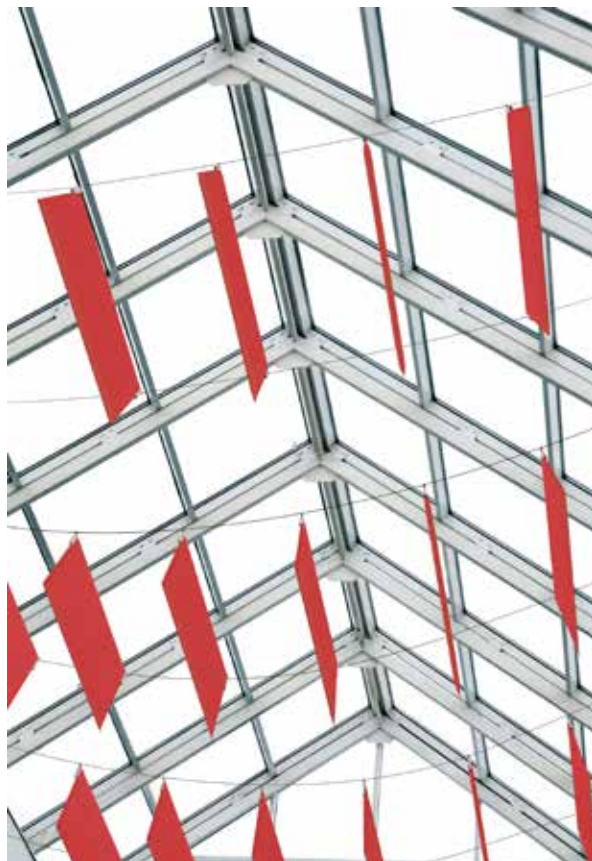

TRA è un prodotto strutturale che richiede accorgimenti specifici per il montaggio. Il nostro ufficio tecnico è a disposizione per qualsiasi informazione.

TRA is a structural product that requires specific mounting devices. Our Technical Department is available for any information.

TRA est un produit structural pour lequel il faut de l'habileté spécifique pour le montage. Notre bureau d'étude est à votre disposition pour tout renseignement.

TRA es un producto estructural que necesita ser instalado en condiciones especiales. Nuestro Dep. tecnico está disponible para cualquier información al respecto.

TRA ist ein strukturelles Produkt, das spezielle Befestigungsvorrichtungen erfordert. Unsere technische Abteilung steht für alle notwendigen Informationen zur Verfügung.



Max. 10 pannelli per coppia di cavi.
Max. 10 panels for each pair of cables.
Max. 10 panneaux pour chaque paire de cables.
Max. 10 Paneele pro Paar-Kabeln.
Max. 10 paneles por 2 cables.

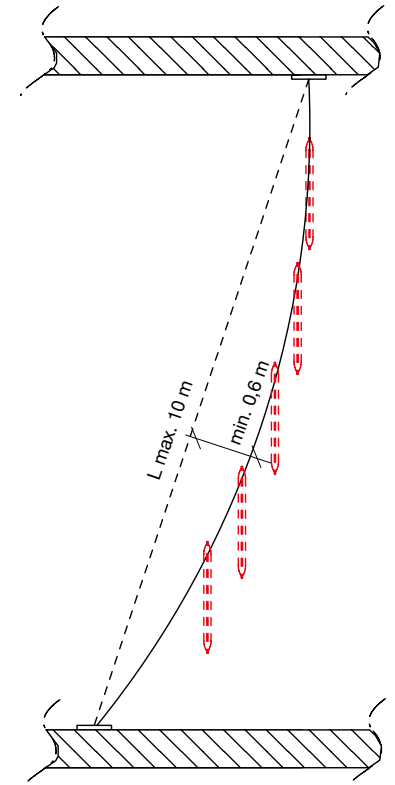
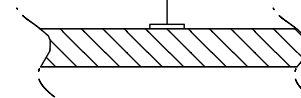
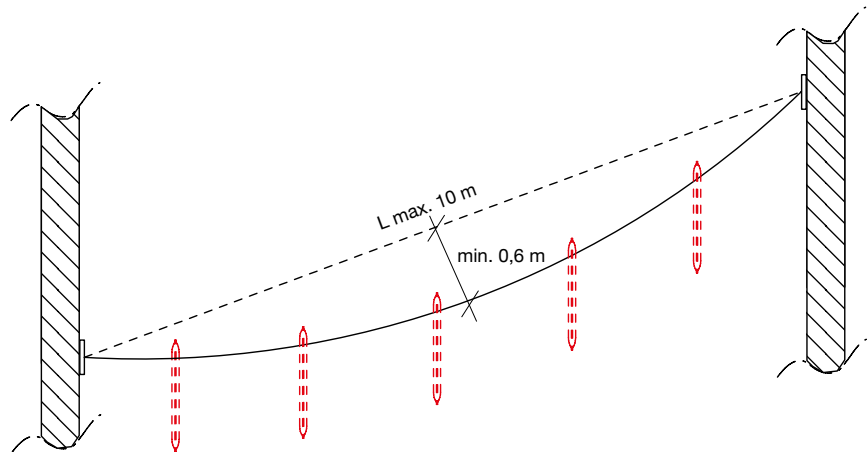
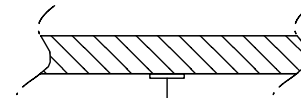
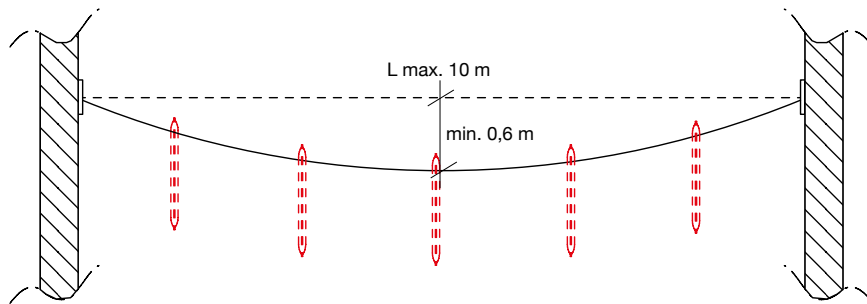

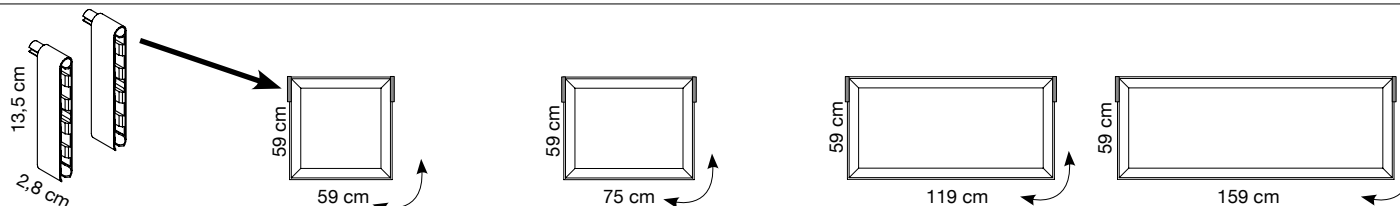

Colore Colour	Codice/Code Prezzo/Price	Codice/Code Prezzo/Price	Codice/Code Prezzo/Price	Codice/Code Prezzo/Price	
Bianco White Blanc	0001	7BT0606-0001	7BT0806-0001	7BT1206-0001	7BT1606-0001
Grigio argento Silver grey Gris argenté	8004	7BT0606-8004	7BT0806-8004	7BT1206-8004	7BT1606-8004
Grigio scuro Dark grey Gris foncé	8007	7BT0606-8007	7BT0806-8007	7BT1206-8007	7BT1606-8007
Beige Beige Beige	1008	7BT0606-1008	7BT0806-1008	7BT1206-1008	7BT1606-1008
Tortora Dove-grey Taupe	2005	7BT0606-2005	7BT0806-2005	7BT1206-2005	7BT1606-2005
Giallo Yellow Jaune	3008	7BT0606-3008	7BT0806-3008	7BT1206-3008	7BT1606-3008
Arancione Orange Orange	4030	7BT0606-4030	7BT0806-4030	7BT1206-4030	7BT1606-4030
Rosso Red Rouge	4027	7BT0606-4027	7BT0806-4027	7BT1206-4027	7BT1606-4027
Verde chiaro Light green Vert clair	7004	7BT0606-7004	7BT0806-7004	7BT1206-7004	7BT1606-7004
Mattone Brick red Rouge brique	4086	7BT0606-4086	7BT0806-4086	7BT1206-4086	7BT1606-4086
Azzurro Light blue Bleu clair	6046	7BT0606-6046	7BT0806-6046	7BT1206-6046	7BT1606-6046
Ottanio Teal Sarcelle	6075	7BT0606-6075	7BT0806-6075	7BT1206-6075	7BT1606-6075
Bianco ghiaccio Cool white Blanc glacier	8002	—	—	7BT1206-8002	7BT1606-8002

Pannello con imbottitura interna in poliester a **densità variabile** Snowsound® Technology. Rivestimento esterno in tessuto di poliester Trevira CS®. Attacchi verniciati.

Panel with polyester internal padding with Snowsound® Technology **variable density**. Polyester covering in Trevira CS® fabric. Powder-coated connections.

Panneau avec rembourrage interne en polyester à **densité variable** Snowsound® Technology. Revêtement externe en tissu de polyester Trevira CS®. Jonctions peint epoxy.

Panel con acolchado interior de poliéster de **densidad variable** Snowsound® Technology. Revestimiento exterior de tejido de poliéster Trevira CS®. Enganches barnizados.

Panel mit Polyester-Füllmaterial von **unterschiedlicher Dichte** Snowsound® Technology. Polyester-Bezug aus Trevira CS®-Material. Beschichtete Verbindungen.

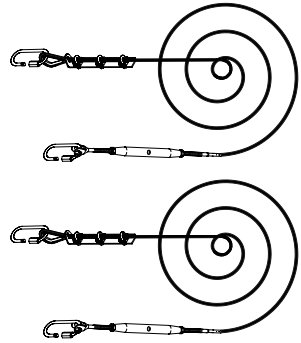

7BT200
Inox

Coppia cavi in acciaio inox \varnothing 5 mm per campata max L. 10 m.

Pair of stainless steel cables \varnothing 5 mm, to reach a maximum span of 10 m.

Paire de cables en acier inox \varnothing 5 mm pour travée max. L. 10 m.

Set de 2 câbles en acero inoxidable \varnothing 5 mm, alcanza un máximo de 10 m.

Ein Paar Edelstahlseile \varnothing 5 mm, für eine maximale Reichweite von 10 m.

\varnothing 20 cm

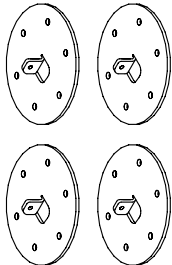

N. 6 fori \varnothing 11 mm
No. 6 holes \varnothing 11 mm

7BT204-GA

Grigio argento
Silver grey
Gris argenté
Gris plata
Silbergrau

Kit 4 piastre in acciaio zincato verniciato con polveri epossidiche per fissaggio cavi 7BT200 a muro.

Set of four epoxy painted galvanized steel plates for cables' 7BT200 wall-fixing.

Jeu de 4 platines en acier zingué peint en époxi pour fixation des cables 7BT200 au mur.

Set de 4 pletinas en acero epoxi galvanizado para fijación a la pared de los cables 7BT200.



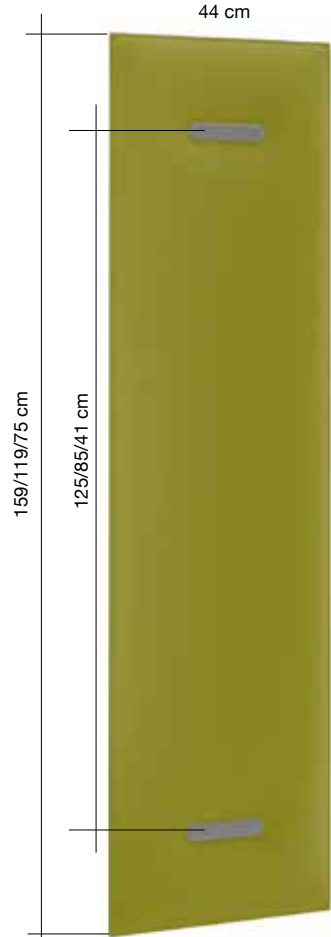

Set von vier Montageplatten aus pulverbeschichtetem, verzinktem Stahl für die Wandbefestigung der Edelstahlseile 7BT200.











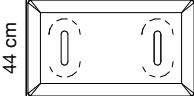





Copertura grigia / Grey cover
Couverture gris / Cobertura gris
Graue Abdeckung

Copertura grigia
Grey cover
Couverture gris
Cobertura gris
Graue Abdeckung

Colore
Colour

		75 cm	119 cm	159 cm
		44 cm	44 cm	44 cm
		Codice/Code Prezzo/Price	Codice/Code Prezzo/Price	Codice/Code Prezzo/Price
	Bianco White Blanc 0001	7M1008-0001	7M1012-0001	7M1016-0001
	Grigio argento Silver grey Gris argenté 8004	7M1008-8004	7M1012-8004	7M1016-8004
	Grigio scuro Dark grey Gris foncté 8007	7M1008-8007	7M1012-8007	7M1016-8007
	Beige Beige Beige 1008	7M1008-1008	7M1012-1008	7M1016-1008
	Tortora Dove-grey Taupe 2005	7M1008-2005	7M1012-2005	7M1016-2005
	Giallo Yellow Jaune 3008	7M1008-3008	7M1012-3008	7M1016-3008
	Arancione Orange Orange 4030	7M1008-4030	7M1012-4030	7M1016-4030
	Rosso Red Rouge 4027	7M1008-4027	7M1012-4027	7M1016-4027
	Verde chiaro Light green Vert clair 7004	7M1008-7004	7M1012-7004	7M1016-7004
	Verde Green Vert 7013	7M1008-7013	7M1012-7013	7M1016-7013
	Blu Blue Bleu 6071	7M1008-6071	7M1012-6071	7M1016-6071
	Nero Black Noir 8033	7M1008-8033	7M1012-8033	7M1016-8033

	Copertura bianca White cover Couverture blanche Cobertura blanca Weisse Abdeckung	Colore Colour	75 cm	119 cm	159 cm
					
			Codice/Code Prezzo/Price	Codice/Code Prezzo/Price	Codice/Code Prezzo/Price
	 Bianco White Blanc	0001	7M1008BO-0001	7M1012BO-0001	7M1016BO-0001
	 Grigio argento Silver grey Gris argenté	8004	7M1008BO-8004	7M1012BO-8004	7M1016BO-8004
	 Grigio scuro Dark grey Gris foncté	8007	7M1008BO-8007	7M1012BO-8007	7M1016BO-8007
	 Beige Beige Beige	1008	7M1008BO-1008	7M1012BO-1008	7M1016BO-1008
	 Tortora Dove-grey Taupe	2005	7M1008BO-2005	7M1012BO-2005	7M1016BO-2005
	 Giallo Yellow Jaune	3008	7M1008BO-3008	7M1012BO-3008	7M1016BO-3008
	 Arancione Orange Orange	4030	7M1008BO-4030	7M1012BO-4030	7M1016BO-4030
	 Rosso Red Rouge	4027	7M1008BO-4027	7M1012BO-4027	7M1016BO-4027
	 Verde chiaro Light green Vert clair	7004	7M1008BO-7004	7M1012BO-7004	7M1016BO-7004
	 Verde Green Vert	7013	7M1008BO-7013	7M1012BO-7013	7M1016BO-7013
	 Blu Blue Bleu	6071	7M1008BO-6071	7M1012BO-6071	7M1016BO-6071
	Nero Black Noir	8033	7M1008BO-8033	7M1012BO-8033	7M1016BO-8033

Copertura bianca / White cover
Couverture blanche / Cobertura
blanca / Weisse Abdeckung

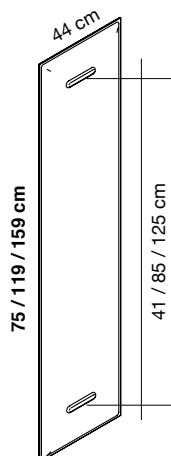

Pannello con imbottitura interna in poliester a **densità variabile** Snowsound® Technology. Rivestimento esterno in tessuto di poliester Trevira CS®.

Completo di attacchi in tecnopolimero e acciaio e coperture frontali in tecnopolimero grigio o bianco.

Il pannello può essere fissato direttamente a parete tramite viti (non incluse). Peso del singolo pannello 2,7 / 2,3 / 1,5 Kg.

Panel with polyester internal padding with Snowsound® Technology **variable density**. Polyester covering in Trevira CS® fabric.

Supplied with connections in high-tech polymer and steel and grey or white high-tech polymer front covers.

The panel can be directly fixed to the wall through screws (not included).

Weight of single panel: 2,7 / 2,3 / 1,5 kg

Panneau avec rembourrage interne en polyester à **densité variable** Snowsound® Technology. Revêtement externe en tissu de polyester Trevira CS®.

Avec jonctions en technopolymère et acier et couvertures frontales en technopolymère gris ou blanc. On peut fixer le panneau directement au mur par des vis (pas incluses). Poids d'un panneau: 2,7 / 2,3 / 1,5 kg

Panel con acolchado interior de poliéster de **densidad variable** Snowsound® Technology. Revestimiento exterior de tejido de poliéster Trevira CS®. Incluye enganches de polímero y acero y coberturas frontales de polímero gris o blanco. El panel puede ser fijado directamente a la pared por medio de tornillos (no incluydos). Peso para singulo panel 2,7 / 2,3 / 1,5 Kg.

Panel mit Polyester-Füllmaterial von **unterschiedlicher Dichte** Snowsound® Technology. Polyester-Bezug aus Trevira CS®-Material. Inklusive Beschlägen aus Technopolymer und Stahl sowie grauen oder weissen Befestigungsabdeckungen aus Technopolymer. Das Paneel kann mit Schrauben (nicht inkludiert) direkt an der Wand montiert werden.

Gewicht eines Paneels: 2,7 / 2,3 / 1,5 kg.



Montaggio semplice a parete pannello Mitesco
Basic wall mounting for Mitesco panel

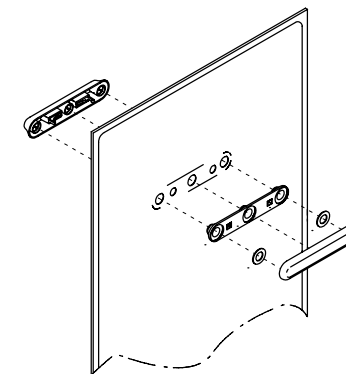

Dettaglio dell'attacco con copertura frontale forniti di serie in colore grigio o bianco.

Le coperture frontali sono disponibili anche colorate cod. 7M102-XXXX (XXXX = Variante colore).

Detail of the connection and front cover in standard grey or white. The front covers are also available in other colors with code 7M102-XXXX (XXXX = Color option).

Détail de la jonction avec couverture frontale, fournie standard en couleur gris ou blanc. Les couvertures frontales sont disponibles aussi dans d'autres couleurs avec réf. 7M102-XXXX (XXXX = option couleur).

Detalle ataque con cobertura frontal incluida en color gris o blanco. Las coberturas frontales son disponibles también en color cod. 7M102-XXXX (XXXX = Variante color).

Detaildarstellung der Befestigungsbeschläge mit standardmäßiger Abdeckung in grau oder weiss. Die Abdeckungen sind auch in anderen Farben erhältlich, Art. 7M102-XXXX (XXXX = Farbvariante).



Dettaglio attacco e copertura frontale colore grigio.

Detail of the connection and front cover. Grey Color.

Détail jonction et couverture frontale, couleur gris.

Detalle ataque y cobertura frontal color gris.

Detaildarstellung der Befestigungsbeschläge und grauer Abdeckung



Dettaglio attacco e copertura frontale colore bianco.

Detail of the connection and front cover. White Color.

Détail jonction et couverture frontale, couleur blanc.

Detalle ataque y cobertura frontal color blanco.

Detaildarstellung der Befestigungsbeschläge und weisser Abdeckung



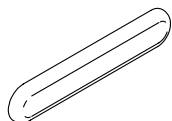

7M102-0001

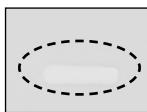

Bianco
White
Blanc
Weiss
Blanco

1 coppia / 1 pair
1 paire / 1 pare
1 Paar

7M102-4030

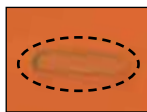

Arancione
Orange
Orange
Anaranjado
Orange

1 coppia / 1 pair
1 paire / 1 pare
1 Paar

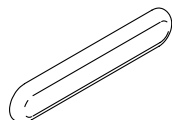

7M102-8004

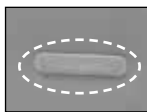

Grigio argento
Silver grey
Gris argenté
Gris plata
Silbergrau

1 coppia / 1 pair
1 paire / 1 pare
1 Paar

7M102-4027

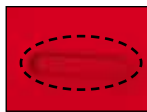

Rosso
Red
Rouge
Rojo
Rot

1 coppia / 1 pair
1 paire / 1 pare
1 Paar

7M102-8007

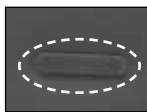

Grigio scuro
Dark grey
Gris foncé
Gris oscuro
Dunkelgrün

1 coppia / 1 pair
1 paire / 1 pare
1 Paar

7M102-7004

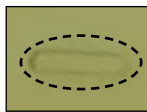

Verde chiaro
Light green
Vert clair
Verde claro
Hellgrün

1 coppia / 1 pair
1 paire / 1 pare
1 Paar

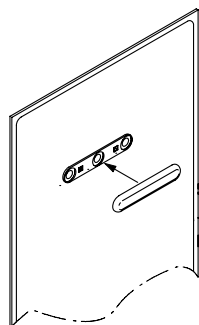

7M102-1008

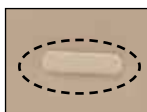

Beige
Beige
Beige
Beige
Beige

1 coppia / 1 pair
1 paire / 1 pare
1 Paar

7M102-7013

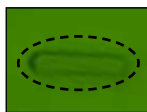

Verde
Green
Vert
Verde
Grüner

1 coppia / 1 pair
1 paire / 1 pare
1 Paar

7M102-2005



Tortora
Dove-grey
Taupe
Tórtola
Taubengrau

1 coppia / 1 pair
1 paire / 1 pare
1 Paar

7M102-6071

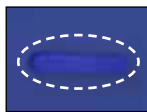

Blu
Blue
Bleu
Azul
Blau

1 coppia / 1 pair
1 paire / 1 pare
1 Paar

7M102-3008

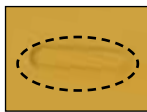

Giallo
Yellow
Jaune
Amarillo
Gelbe

1 coppia / 1 pair
1 paire / 1 pare
1 Paar

7M102-8033



Nero
Black
Noir
Negro
Schwarz

1 coppia / 1 pair
1 paire / 1 pare
1 Paar

Coppia di coperture frontali in tecnopolimero degli attacchi per 1 pannello Mitesco.

OPZIONALE

(Il pannello Mitesco è fornito di serie con le coperture frontali di colore grigio o bianco)

Pair of high-tech polymer front covers for connections for 1 panel Mitesco.

OPTIONAL

(Mitesco panels are supplied as standard with grey or white front covers)

Paire de couvertures frontales en technopolymère pour jonctions pour 1 panneau Mitesco.

OPTIONNEL

(Le panneau Mitesco est fourni en standard avec les couvertures frontales en couleur gris ou blanc)

Par de coberturas frontales de tecnopolimero para enganches de 1 panel Mitesco.

OPCIONAL

(el panel Mitesco ya incluye las coberturas frontales en color gris o blanco)

Paar Abdeckungen aus Technopolymer für Befestigung für 1 Paneel Mitesco.

OPTIONAL erhältlich

(Mitesco-Paneele werden standardmäßig mit grauen oder weissen Befestigungsabdeckungen geliefert).

NOTA

Non utilizzare con staffe scrivania cod. 7M511-XX / 7M515-XX / 7M5100-XX / 7M519-XX / 7M518-XX / 7M517-XX (XX = Variante colore).

Not to be used with desk brackets code 7M511-XX / 7M515-XX / 7M5100-XX / 7M519-XX / 7M518-XX / 7M517-XX (XX = Color option).

Ne pas utiliser avec étriers pour bureau réf 7M511-XX / 7M515-XX / 7M5100-XX / 7M519-XX / 7M518-XX / 7M517-XX (XX = option couleur).

No utilizar con abrazaderas para mesa cod. 7M511-XX / 7M515-XX / 7M5100-XX / 7M519-XX / 7M518-XX / 7M517-XX (XX = Variante color).

Nicht zur Verwendung mit Halterungen für Tisch Art. 7M511-XX / 7M515-XX / 7M5100-XX / 7M519-XX / 7M518-XX / 7M517-XX (XX = Farbvariante).

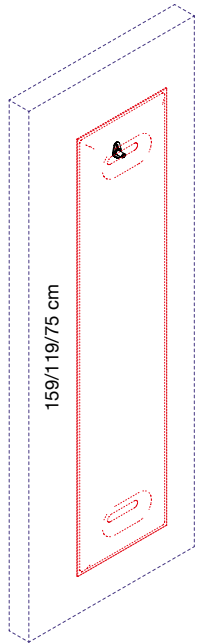
**7M210-GR**

Grigio
Grey
Gris
Gris
Grau

Aggancio semplice in tecnopolimero per fissaggio a parete tramite chiodo/vite (non inclusi) di un pannello Mitesco.

Easy connection in high-tech polymer for wall fixing by nail/screw (not included) of 1 Mitesco panel.

Accrochage simple en technopolymère pour fixation au mur par un clou/vis (pas inclus) d'un panneau Mitesco.

Enganche simple de polímero para fijación a pared por medio de clavo / tornillo (no incluydo) de un panel Mitesco.

Einfache Befestigung aus Technopolymer für die Wandmontage mittels Nagel/Schraube (nicht inkludiert) eines Mitesco-Panels.

ø 3 cm

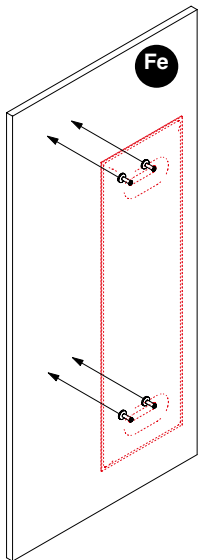
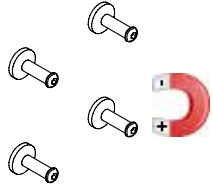

Fe = Ferro
Iron
Fer
Hierro
Eisen

**7M232**

Kit 4 magneti per il fissaggio diretto ad una superficie verticale in ferro di un pannello Mitesco.

Set of 4 magnets for direct fixing to a vertical iron surface, of 1 Mitesco panel.

Jeu de 4 aimants pour la fixation directe à une surface verticale en fer d'un panneau Mitesco.

Kit de 4 imanes para la fijación directa a una superficie vertical de hierro de un panel Mitesco.

Set von 4 Magneten zur direkten Befestigung auf einer vertikalen Eisenoberfläche, für 1 Mitesco-Paneel.

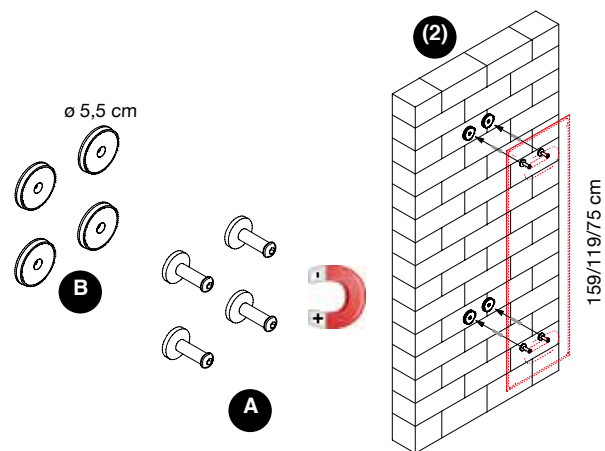
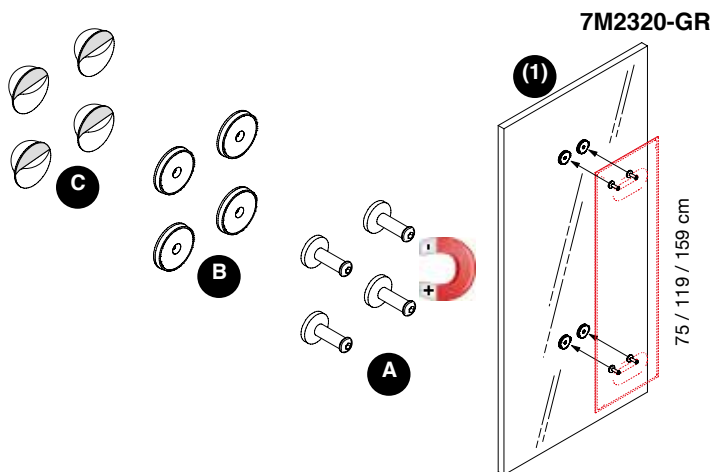

Kit per il fissaggio ad una superficie verticale in vetro o in muratura di un pannello Mitesco. Il kit è composto da: 4 magneti (A) / 4 dischi in acciaio e tecnopolimero grigio (B) / 4 dischi con biadesivo (C).

(1) Per le superfici in vetro applicare gli appositi dischetti con biadesivo (C).

(2) Per le superfici in muratura applicare direttamente i dischetti (B) tramite viti (non incluse)

Set for fixing to a glass or masonry vertical surface, of 1 Mitesco panel. Set composed of: 4 magnets (A) / 4 steel and high-tech polymer plates (B) / 4 plates with double-sided adhesive tape (C).

(1) For glass surfaces use the suitable plates with double-sided adhesive tape (C)

(2) For masonry surfaces fix directly the plates (B) with screws (not included)

Jeu pour fixation à une surface verticale en verre ou maçonnerie d'un panneau Mitesco. Le jeu se compose de: 4 aimants (A) / 4 disques en acier et technopolymère (B) / 4 disques avec bande biadhésive (C).

(1) Pour les surfaces en verre appliquer les disques par bande biadhésive (C)

(2) Pour les surfaces en maçonnerie appliquer directement les disques (B) par des vis (pas incluses)

Kit para fijación a una superficie vertical de vidrio o de mampostería de un panel Mitesco. Kit compuesto por: 4 imanes (A) / 4 discos de acero y polímero (B) / 4 discos con bi-adhesivo (C).

(1) Para las superficies de vidrio aplicar los discos con su propio bi-adhesivo (C)

(2) Para las superficies de mampostería aplicar directamente los discos (B) con tornillos (no incluidos)

Set zur Montage auf vertikal Glasoberflächen und Mauerwerk, für 1 Mitesco-Paneel. Set von: 4 Magneten (A) / 4 Scheiben aus Stahl und Technopolymer (B) / 4 doppelseitig klebende Scheiben (C).

(1) Für Glasoberflächen verwenden Sie die entsprechenden doppelseitig klebenden Scheiben (C)

(2) Für Mauerwerk befestigen Sie die Scheiben direkt (B) mit Schrauben (nicht inkludiert)

MAGNETIC



7M2320-GR



MITESCO WALL

design Michele De Lucchi

Snowsound® technology by Caimi Brevetti

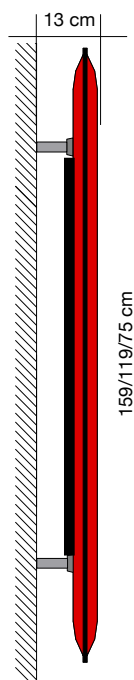
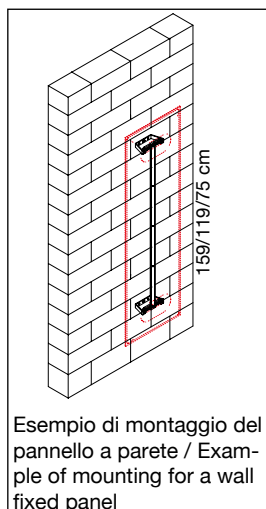
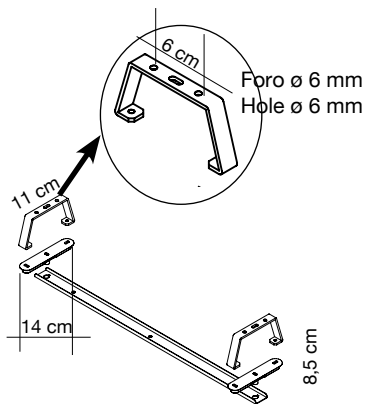

7M2476-GA Grigio argento
Silver grey
Gris argenté
Gris plata
Silbergrau

Per pannelli
For panels
L. 159 cm

Coppia attacchi distanziali in acciaio verniciato con polveri epossidiche e tecnopolimero per parete, completi di profilo livellatore per pannello Mitesco. Per montaggio a PARETE

Pair of spacer connections in powder coated steel and high-tech polymer for wall, supplied with leveler profile for Mitesco panel. For WALL mounting

7M2472-GA Grigio argento
Silver grey
Gris argenté
Gris plata
Silbergrau

Per pannelli
For panels
L. 119 cm

Paire d'accrochages espaceurs en acier peint en époxy et technopolymère pour mur, avec un profil niveleur pour panneau Mitesco. Pour montage MURAL

Par de enganches espaciadores de acero recubierto epoxi y polímero para pared, incluye perfil nivelador para panel Mitesco. Para montaje en PARED

Paar Distanzhalterbefestigungen aus pulverbeschichtetem Stahl und Technopolymer zur Wandmontage, inkl. Justierungsprofil für Mitesco-Paneel. Für WANDMONTAGE

7M2478-GA Grigio argento
Silver grey
Gris argenté
Gris plata
Silbergrau

Per pannelli
For panels
L. 75 cm

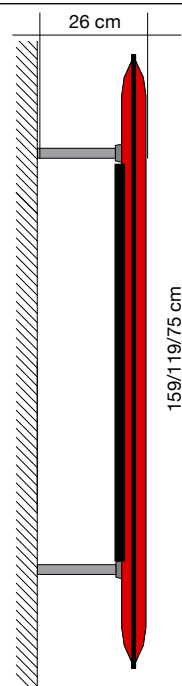
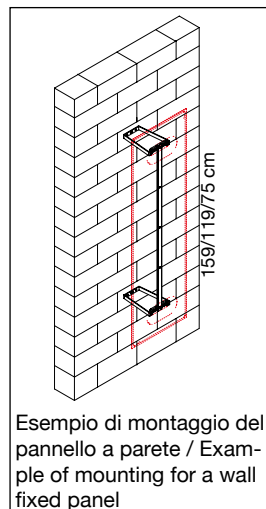
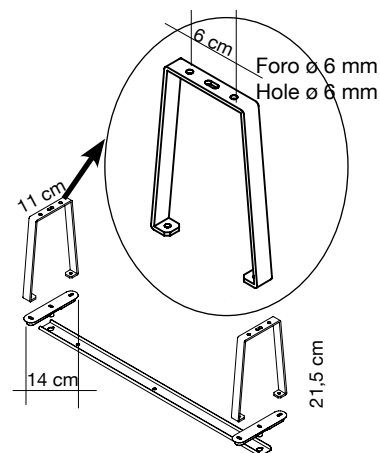

7M2426-GA Grigio argento
Silver grey
Gris argenté
Gris plata
Silbergrau

Per pannelli
For panels
L. 159 cm

Coppia attacchi distanziali in acciaio verniciato con polveri epossidiche e tecnopolimero per parete, completi di profilo livellatore per pannello Mitesco. Per montaggio a PARETE

Pair of spacer connections in powder coated steel and high-tech polymer for wall, supplied with leveler profile for Mitesco panel. For WALL mounting

7M2422-GA Grigio argento
Silver grey
Gris argenté
Gris plata
Silbergrau

Per pannelli
For panels
L. 119 cm

Paire d'accrochages espaceurs en acier peint en époxy et technopolymère pour mur, avec un profil niveleur pour panneau Mitesco. Pour montage MURAL

Par de enganches espaciadores de acero recubierto epoxi y polímero para pared, incluye perfil nivelador para panel Mitesco. Para montaje en PARED

Paar Distanzhalterbefestigungen aus pulverbeschichtetem Stahl und Technopolymer zur Wandmontage, inkl. Justierungsprofil für Mitesco-Paneel. Für WANDMONTAGE

7M2428-GA Grigio argento
Silver grey
Gris argenté
Gris plata
Silbergrau

Per pannelli
For panels
L. 75 cm

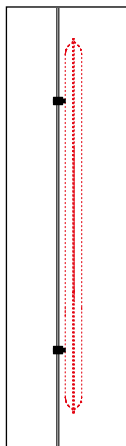
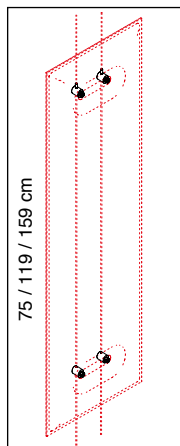
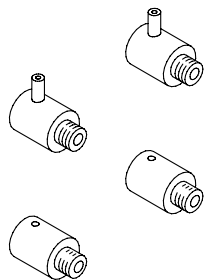

**7M214**

Kit 4 morsetti in metallo per cavi cod. 7M5170.
Applicabili direttamente a un pannello Mitesco.

Set of 4 steel clamps to use with cables code 7M5170
They can be applied directly to the Mitesco panel.

Jeu de 4 étaux en métal pour câbles réf. 7M5170.
On peut les appliquer directement à un panneau Mitesco.

Kit de 4 sujetadores de metal para cables cod. 7M5170.
Aplicables directamente a un panel Mitesco.

Set von 4 Klemmen zur Verwendung mit Stahlseilen Art. 7M5170.
Befestigung der Klemmen direkt am Mitesco-Paneel.

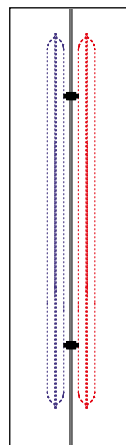
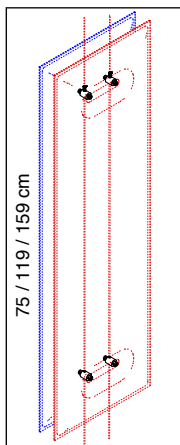
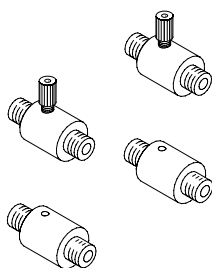
**7M218**

Kit 4 morsetti bifronte in metallo per cavi cod. 7M5170.
Applicabili direttamente a un pannello Mitesco.

Set of 4 double-sided steel clamps to use with cables code 7M5170
They can be applied directly to the Mitesco panel.

Jeu de 4 étaux bifronts en métal pour câbles réf. 7M5170.
On peut les appliquer directement à un panneau Mitesco.

Kit de 4 sujetadores doble cara de metal para cables cod. 7M5170.
Aplicables directamente a un panel Mitesco.

Set von 4 doppelseitiger Klemmen zur Verwendung mit Stahlseilen
Art. 7M5170.
Befestigung der Klemmen direkt am Mitesco-Paneel.

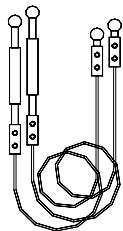

Portata massima
Maximum load

7M5170

1 coppia / 1 pair
1 paire / 1 par
1 Paar



1 coppia cavi d'acciaio (4+4 m) + 1 coppia tiranti

Pair of steel cables (4+4 m) + pair of tension rods

Paire de cables en acier (4+4 m) + paire de tirants

Par de cables de acero (4+4 m) + par de pesos

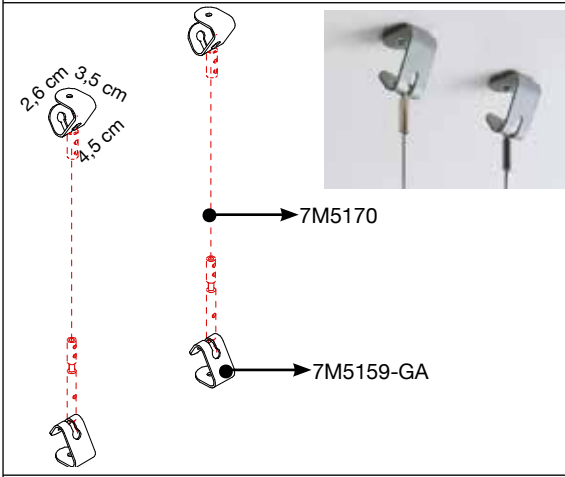
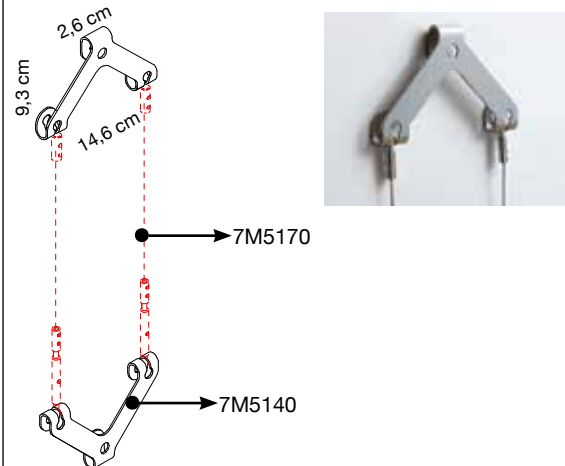
1 Paar Stahlseile (4+4 m) + 1 Paar Befestigungsendstücken

	<p>7M5158-GA Grigio argento Silver grey Gris argenté Gris plata Silbergrau</p> <p>2 coppie / 2 pairs 2 paires / 2 pares 2 Paar</p>	<p>1 coppia supporti in acciaio verniciato con polveri epossidiche per fissaggio a parete del cod. 7M5170. (Viti non incluse)</p> <p>1 pair of powder-coated steel supports for wall fixing of code 7M5170. (Screws not included)</p>
	<p>7M5158-BO Bianco opaco Mat white Blanc mat Blanco mate Mattweiß</p> <p>2 coppie / 2 pairs 2 paires / 2 pares 2 Paar</p>	<p>1 paire de supports en acier peint époxy pour fixation murale de la réf. 7M5170. (Vis pas incluses)</p> <p>1 par de soportes de acero recubierto epoxi para fijación a pared para cod. 7M5170. (Tornillos no incluidos)</p> <p>1 Paar Wandbefestigungen aus pulverbeschichtetem Stahl für Art. 7M5170. (Schrauben nicht inkludiert)</p>
	<p>7M5159-GA Grigio argento Silver grey Gris argenté Gris plata Silbergrau</p> <p>2 coppie / 2 pairs 2 paires / 2 pares 2 Paar</p>	<p>2 coppie in acciaio verniciato con polveri epossidiche per fissaggio a pavimento/soffitto del cod. 7M5170. (Viti non incluse)</p> <p>2 pairs of powder-coated steel supports for floor/ceiling fixing of code 7M5170. (Screws not included)</p>
	<p>7M5159-BO Bianco opaco Mat white Blanc mat Blanco mate Mattweiß</p> <p>2 coppie / 2 pairs 2 paires / 2 pares 2 Paar</p>	<p>2 paires de supports en acier peint époxy pour fixation sol/plafond de la réf. 7M5170. (Vis pas incluses)</p> <p>2 pares de soportes de acero recubierto epoxi para fijación suelo/techo para cod. 7M5170. (Tornillos no incluidos)</p> <p>2 Paar Decken/Bodenbefestigungen aus pulverbeschichtetem Stahl für Art. 7M5170. (Schrauben nicht inkludiert)</p>
	<p>7M5140 Grigio argento Silver grey Gris argenté Gris plata Silbergrau</p> <p>1 coppia / 1 pair 1 paire / 1 pare 1 Paar</p>	<p>1 coppia supporti in acciaio verniciato con polveri epossidiche per fissaggio a parete del cod. 7M5170. (Viti non incluse)</p> <p>1 pair of powder-coated steel supports for wall fixing of code 7M5170. (Screws not included)</p>
	<p>7M5140-BO Bianco opaco Mat white Blanc mat Blanco mate Mattweiß</p> <p>1 coppia / 1 pair 1 paire / 1 pare 1 Paar</p>	<p>1 paire de supports en acier peint époxy pour fixation murale de la réf. 7M5170. (Vis pas incluses)</p> <p>1 par de soportes de acero recubierto epoxi para fijación a pared para cod. 7M5170. (Tornillos no incluidos)</p> <p>1 Paar Wandbefestigungen aus pulverbeschichtetem Stahl für Art. 7M5170. (Schrauben nicht inkludiert)</p>



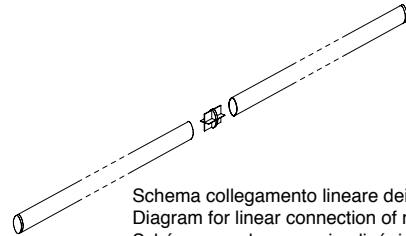
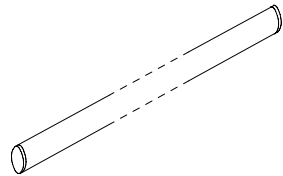
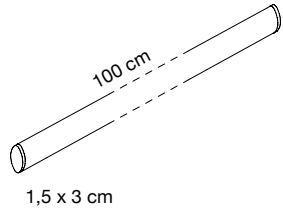

Schema collegamento lineare dei tubi
Diagram for linear connection of rails
Schéma pour la connexion linéaire des tubes
Schema de connexion linear de los tubos
Schema der gerader Stangenverbindung

7M5180

Cromato
Chrome-plated
Chromé
Cromado
Verchromt

1 coppia / 1 pair
1 paire / 1 pare
1 Paar

Coppia tubi ellittici in acciaio cromato completi di giunto per collegamento lineare.

Pair of elliptical rails in chrome-plated steel with joint for linear connection

Paire de tubes elliptiques en acier chromé avec jonction pour connexion linéaire

Par de tubos elícticos de acero cromado con enganche para enlace linear incluydo

1 Paar ovale Stangen aus verchromtem Stahl mit geradem Verbindungsstück

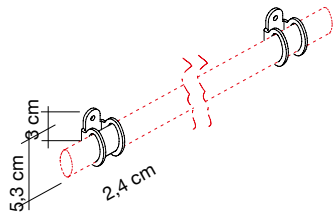
**7M5160-GA**

Grigio argento
Silver grey
Gris argenté
Gris plata
Silbergrau

2 coppie / 2 pairs
2 paires / 2 pare
2 Paar

2 coppie fissaggi a parete in acciaio verniciato con polveri epossidiche per cod. 7M5180. (Viti non incluse)

2 pairs of powder-coated steel wall connections for code 7M5180. (Screws not included)

2 paires de fixations murales en acier peint époxy pour réf. 7M5180. (Vis pas incluses)

7M5160-BO

Bianco opaco
Mat white
Blanc mat
Blanco mate
Mattweiß

2 coppie / 2 pairs
2 paires / 2 pare
2 Paar

2 pares de soportes à pared de acero recubierto epoxi para cod. 7M5180. (Tornillos no incluidos)

2 Paar Wandbefestigungen aus pulverbeschichtetem Stahl für Art.7M5180. (Schrauben nicht inkludiert)

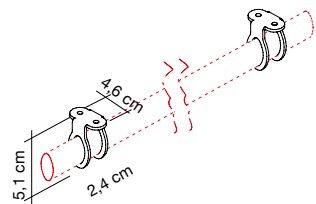
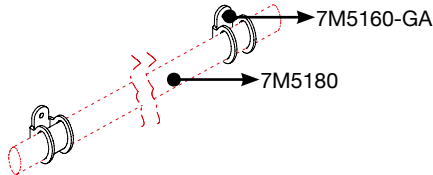
**7M5161-GA**

Grigio argento
Silver grey
Gris argenté
Gris plata
Silbergrau

2 coppie / 2 pairs
2 paires / 2 pare
2 Paar

2 coppie fissaggi a soffitto/pavimento in acciaio verniciato con polveri epossidiche per cod. 7M5180. (Viti non incluse)

2 pairs of powder-coated steel floor/ceiling connections for code 7M5180. (Screws not included)

2 paires de fixations sol/plafond en acier peint époxy pour réf. 7M5180. (Vis pas incluses)

7M5161-BO

Bianco opaco
Mat white
Blanc mat
Blanco mate
Mattweiß

2 coppie / 2 pairs
2 paires / 2 pare
2 Paar

2 pares de soportes suelo/techo de acero recubierto epoxi para cod. 7M5180. (Tornillos no incluidos)

2 Paar Decken/Bodenbefestigungen aus pulverbeschichtetem Stahl für Art. 7M5180. (Schrauben nicht inkludiert)

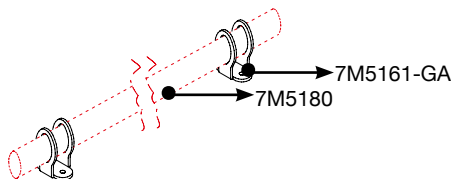

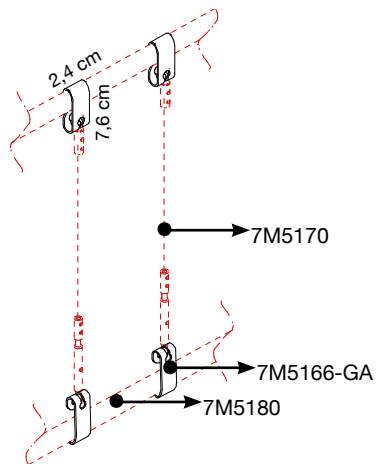

7M5166-GA

Grigio argento
Silver grey
Gris argenté
Gris plata
Silbergrau

2 coppie / 2 pairs
2 paires / 2 pare
2 Paar

2 coppie supporti in acciaio verniciato con polveri epossidiche per cod. 7M5180 e 7M5170

2 pairs of powder-coated steel supports for code 7M5180 and 7M5170

2 paires de supports en acier peint époxy pour réf. 7M5180 et 7M5170

7M5166-BO

Bianco opaco
Mat white
Blanc mat
Blanco mate
Mattweiß

2 coppie / 2 pairs
2 paires / 2 pare
2 Paar

2 pares de soportes de acero recubierto epoxi para cod. 7M5180 y 7M5170

2 Paar Befestigungshaken aus pulverbeschichtetem Stahl für Art. 7M5180 und 7M5170



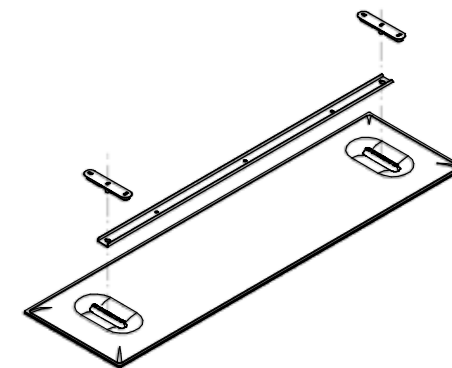
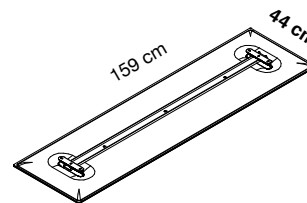
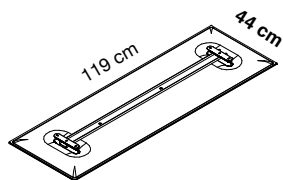
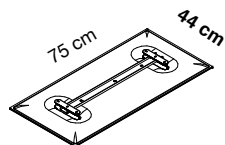

Colore Colour	Codice/Code Prezzo/Price	Codice/Code Prezzo/Price	Codice/Code Prezzo/Price
Bianco White Blanc	0001 7MC80-0001	7MC120-0001	7MC160-0001
Grigio argento Silver grey Gris argenté	8004 7MC80-8004	7MC120-8004	7MC160-8004
Grigio scuro Dark grey Gris foncé	8007 7MC80-8007	7MC120-8007	7MC160-8007
Beige Beige Beige	1008 7MC80-1008	7MC120-1008	7MC160-1008
Tortora Dove-grey Taupe	2005 7MC80-2005	7MC120-2005	7MC160-2005
Giallo Yellow Jaune	3008 7MC80-3008	7MC120-3008	7MC160-3008
Arancione Orange Orange	4030 7MC80-4030	7MC120-4030	7MC160-4030
Rosso Red Rouge	4027 7MC80-4027	7MC120-4027	7MC160-4027
Verde chiaro Light green Vert clair	7004 7MC80-7004	7MC120-7004	7MC160-7004
Verde Green Vert	7013 7MC80-7013	7MC120-7013	7MC160-7013
Blu Blue Bleu	6071 7MC80-6071	7MC120-6071	7MC160-6071
Nero Black Noir	8033 7MC80-8033	7MC120-8033	7MC160-8033

Pannello con imbottitura interna in poliester a **densità variabile** Snowsound® Technology. Rivestimento esterno in tessuto di poliester Trevira CS®. **Completo di profilo livellatore e attacchi per fissaggio a soffitto in metallo. Coperture frontali in metallo dello stesso colore del pannello.**

Panel with polyester internal padding with Snowsound® Technology **variable density**. Polyester covering in Trevira CS® fabric. **Complete with levelling profile and metal connections for fixing to ceiling. Metal front coverings in the same color as the panel.**

Panneau avec rembourrage interne en polyester à **densité variable** Snowsound® Technology. Revêtement externe en tissu de polyester Trevira CS®. **Fourni avec profil niveleur et joints en métal pour l'installation au plafond. Caches frontales en métal dans la même couleur du panneau.**

Panel con acolchado interior de poliéster de **densidad variable** Snowsound® Technology. Revestimiento exterior de tejido de poliéster Trevira CS®. **Se completa con un perfil nivelador y fijaciones de metal para techo. Coberturas frontales de metal del mismo color del panel.**

Paneel mit Polyester-Füllmaterial von **unterschiedlicher Dichte** Snowsound® Technology. Polyester-Bezug aus Trevira CS®-Material. **Deckenaufhängungs-Kit mit Nivellierprofil und Deckenbefestigungen aus Metall. Frontabdeckungen aus Metall in derselben Farbe wie den Paneel.**



Foro ø 6 mm
Hole ø 6 mm

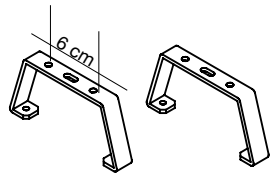

Esempio di montaggio del pannello a soffitto
Example of mounting for a ceiling fixed panel.
Da utilizzare con codici / To be used with
codes:
7MC80-XXXX
7MC120-XXXX
7MC160-XXXX

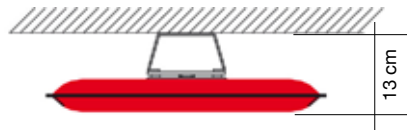

7MC247-GR

Grigio argento
Silver grey
Gris argenté
Gris plata
Silbergrau

1 coppia / 1 pair
1 paire / 1 pare
1 Paar

Coppia attacchi distanziali in acciaio verniciato con polveri epossidiche.

Per montaggio a SOFFITTO utilizzare con codici: 7MC80-XXXX - 7MC120-XXXX - 7MC160-XXXX

Pair of spacer connections in powder coated steel and high-tech polymer for ceiling.

For CEILING mounting use with codes: 7MC80-XXXX - 7MC120-XXXX - 7MC160-XXXX

Paire d'accrochages espaceurs en acier peint en époxy et technopolymère pour plafond.

Pour l'installation au plafond utiliser avec les réf.: 7MC80-XXXX - 7MC120-XXXX - 7MC160-XXXX

Par de enganches espaciadores de acero recubierto epoxi y polímero para techo.

Para montaje en TECHO usar con códigos: 7MC80-XXXX - 7MC120-XXXX - 7MC160-XXXX

Paar Distanzhalterbefestigungen aus pulverbeschichtetem Stahl und Technopolymer zur Deckenmontage.

Für DECKEN-Befestigung mit Art. 7MC80-XXXX - 7MC120-XXXX - 7MC160-XXXX benutzen.

Foro ø 6 mm
Hole ø 6 mm

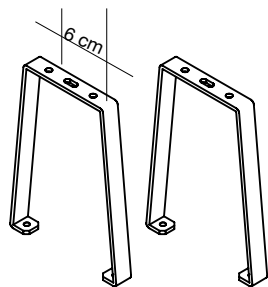

Esempio di montaggio del pannello a soffitto
Example of mounting for a ceiling fixed panel.
Da utilizzare con codici / To be used with
codes:
7MC80-XXXX
7MC120-XXXX
7MC160-XXXX

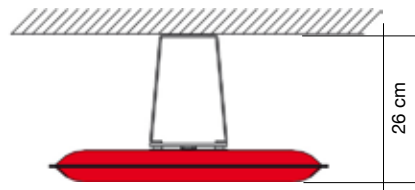

7MC242-GR

Grigio argento
Silver grey
Gris argenté
Gris plata
Silbergrau

1 coppia / 1 pair
1 paire / 1 pare
1 Paar

Coppia attacchi distanziali in acciaio verniciato con polveri epossidiche.

Per montaggio a SOFFITTO utilizzare con codici: 7MC80-XXXX - 7MC120-XXXX - 7MC160-XXXX

Pair of spacer connections in powder coated steel and high-tech polymer for ceiling.

For CEILING mounting use with codes: 7MC80-XXXX - 7MC120-XXXX - 7MC160-XXXX

Paire d'accrochages espaceurs en acier peint en époxy et technopolymère pour plafond.

Pour l'installation au plafond utiliser avec les réf.: 7MC80-XXXX - 7MC120-XXXX - 7MC160-XXXX

Par de enganches espaciadores de acero recubierto epoxi y polímero para techo.

Para montaje en TECHO usar con códigos: 7MC80-XXXX - 7MC120-XXXX - 7MC160-XXXX

Paar Distanzhalterbefestigungen aus pulverbeschichtetem Stahl und Technopolymer zur Deckenmontage.

Für DECKEN-Befestigung mit Art. 7MC80-XXXX - 7MC120-XXXX - 7MC160-XXXX benutzen.

MITESCO TOTEM

design **Michele De Lucchi**
Snowsound® technology by **Caimi Brevetti**

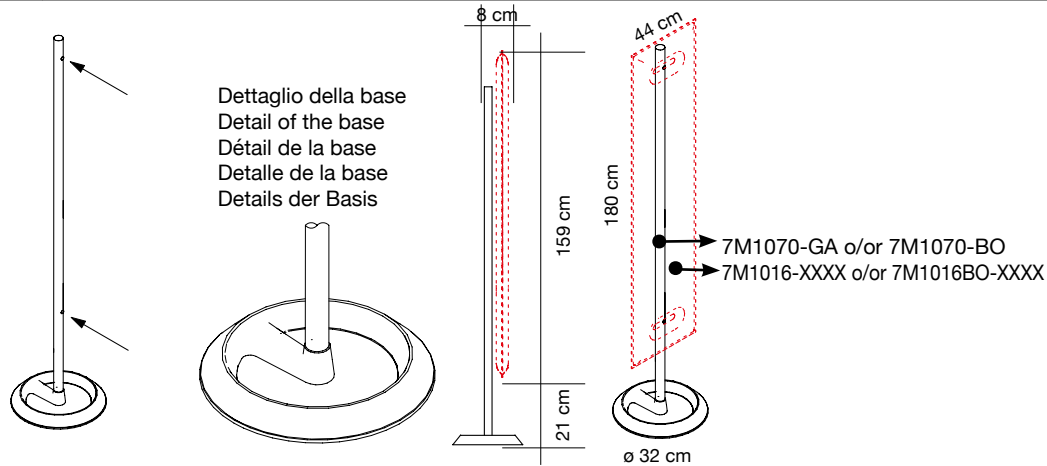

7M1070-GA
Grigio argento
Silver grey
Gris argenté
Gris plata
Silbergrau

7M1070-BO
Bianco opaco
Mat white
Blanc mat
Blanco mate
Mattweiß

Struttura in acciaio verniciato con polveri epossidiche con base in ghisa verniciata con polveri epossidiche per il montaggio di **1** pannello Mitesco 7M1016-XXXX, 7M1016BO-XXXX (XXXX = Variante colore).

Structure in powder-coated steel with base in powder-coated cast iron to mount **1** Mitesco panel code 7M1016-XXXX, 7M1016BO-XXXX (XXXX = Color option).

Structure en acier peint époxy avec base en fonte peinte époxy pour le montage de **1** panneau Mitesco réf. 7M1016-XXXX, 7M1016BO-XXXX (XXXX = option couleur)

Estructura de acero recubierto epoxi con base de hierro fundido recubierto epoxi para el montaje de **1** panel Mitesco 7M1016-XXXX, 7M1016BO-XXXX (XXXX = Variante color).

Standssäule aus pulverbeschichtetem Stahl mit Standfuß aus pulverbeschichtetem Gusseisen zur Aufstellung von **1** Mitesco-Panel Art. 7M1016-XXXX, 7M1016BO-XXXX (XXXX = Farbvariante).

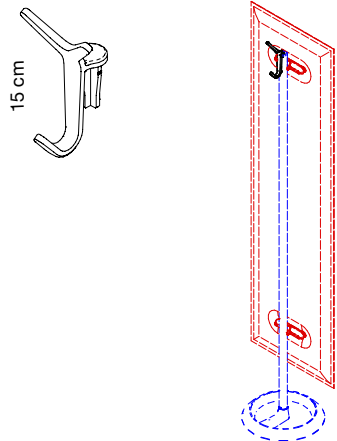

7M1697
Alluminio lucidato
Polished aluminium
Aluminium poli
Aluminio pulido
Poliertem Aluminium

Gancio portabiti in alluminio lucidato per strutture cod. 7M1070-GA e 7M1070-BO. **OPZIONALE**

Polished aluminium hook for structures code 7M1070-GA and 7M1070-BO. **OPTIONAL**

Crochet en aluminium poli pour structures code 7M1070-GA et 7M1070-BO. **OPTIONNEL**

Gancho en aluminio pulido para estructuras code 7M1070-GA y 7M1070-BO. **OPCIONAL**

Haken aus poliertem Aluminium für Standssäule Art. 7M1070-GA eund 7M1070-BO. **OPTIONAL erhältlich**

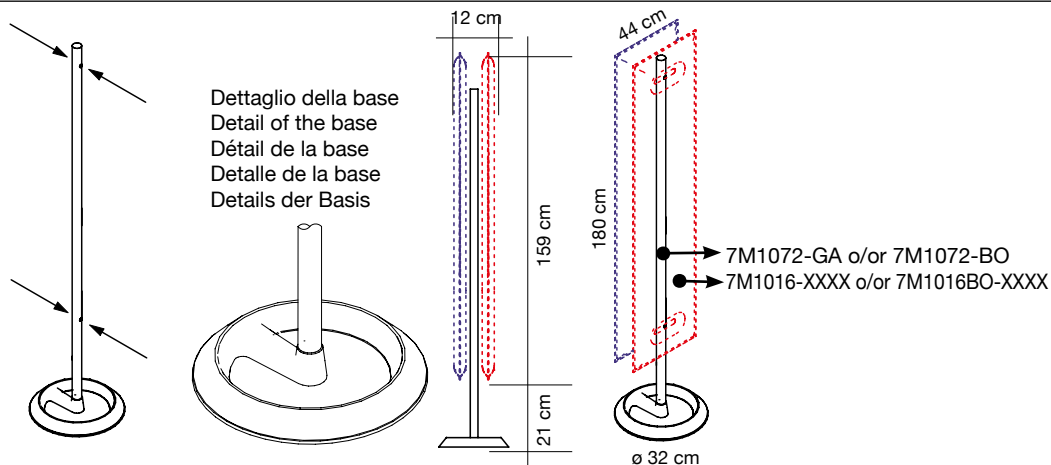

7M1072-GA
Grigio argento
Silver grey
Gris argenté
Gris plata
Silbergrau

7M1072-BO
Bianco opaco
Mat white
Blanc mat
Blanco mate
Mattweiß

Struttura in acciaio verniciato con polveri epossidiche con base in ghisa verniciata con polveri epossidiche per il montaggio di **2** pannelli Mitesco 7M1016-XXXX, 7M1016BO-XXXX (XXXX = Variante colore).

Structure in powder-coated steel with base in powder-coated cast iron to mount **2** Mitesco panels code 7M1016-XXXX, 7M1016BO-XXXX (XXXX = Color option).

Structure en acier peint époxy avec base en fonte peinte époxy pour le montage de **2** panneaux Mitesco réf. 7M1016-XXXX, 7M1016BO-XXXX (XXXX = option couleur)

Estructura de acero recubierto epoxi con base de hierro fundido recubierto epoxi para el montaje de **2** panels Mitesco 7M1016-XXXX, 7M1016BO-XXXX (XXXX = Variante color).

Standssäule aus pulverbeschichtetem Stahl mit Standfuß aus pulverbeschichtetem Gusseisen zur Aufstellung von **2** Mitesco-Panel Art. 7M1016-XXXX, 7M1016BO-XXXX (XXXX = Farbvariante).





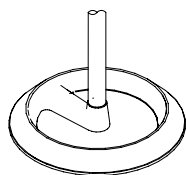

Dettaglio della base
Detail of the base
Détail de la base
Detalle de la base
Details der Basis

STRUTTURA MONOFRONTE ONE-SIDED FRAME

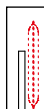

Dimension Codice/Code Prezzo/Price	Dimension Codice/Code Prezzo/Price	Dimension Codice/Code Prezzo/Price
--	--	--

Struttura in acciaio verniciato con polveri epossidiche con basi in ghisa verniciata con polveri epossidiche per il montaggio di 3 pannelli Mitesco.

Structure in powder-coated steel with bases in powder-coated cast iron to mount 3 Mitesco panels.

Structure en acier peint époxy avec bases en fonte peinte époxy pour le montage de 3 panneaux Mitesco.

Estructura de acero recubierto epoxi con bases de hierro fundido recubierto epoxi para el montaje de 3 paneles Mitesco.

Standssäulen aus pulverbeschichtetem Stahl mit Standfuß aus pulverbeschichtetem Gusseisen zur Aufstellung von 3 Mitesco-Paneelen.

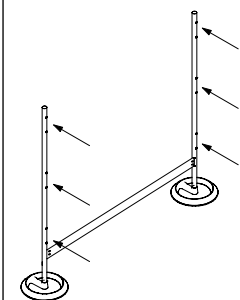

Grigio argento
Silver grey
Gris argenté
Gris plata
Silbergrau

Per pannelli For panels	Per pannelli For panels	Per pannelli For panels
L. 75 cm 7M3870-GA	L. 119 cm 7M3270-GA	L. 159 cm 7M3670-GA

Bianco opaco
Mat white
Blanc mat
Blanco mate
Mattweiß

Per pannelli For panels	Per pannelli For panels	Per pannelli For panels
L. 75 cm 7M3870-BO	L. 119 cm 7M3270-BO	L. 159 cm 7M3670-BO

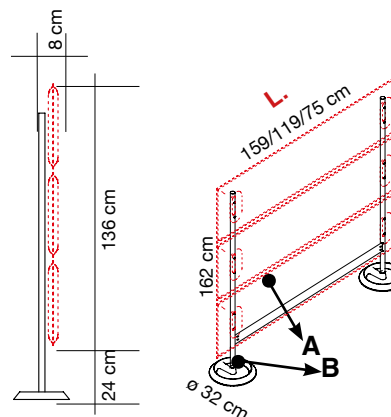

A	7M1008-XXXX o/or 7M1008BO-XXXX	L. 75 cm
B	7M3870-GA o/or 7M3870-BO	

o/or

A	7M1012-XXXX o/or 7M1012BO-XXXX	L. 119 cm
B	7M3270-GA o/or 7M3270-BO	

o/or

A	7M1016-XXXX o/or 7M1016BO-XXXX	L. 159 cm
B	7M3670-GA o/or 7M3670-BO	

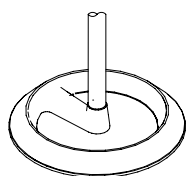

Dettaglio della base
Detail of the base
Détail de la base
Detalle de la base
Details der Basis

STRUTTURA BIFRONTE DOUBLE-SIDED FRAME

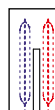

Dimension Codice/Code Prezzo/Price	Dimension Codice/Code Prezzo/Price	Dimension Codice/Code Prezzo/Price
--	--	--

Struttura in acciaio verniciato con polveri epossidiche con basi in ghisa verniciata con polveri epossidiche per il montaggio di 6 pannelli Mitesco.

Structure in powder-coated steel with bases in powder-coated cast iron to mount 6 Mitesco panels.

Structure en acier peint époxy avec bases en fonte peinte époxy pour le montage de 6 panneaux Mitesco.

Estructura de acero recubierto epoxi con bases de hierro fundido recubierto epoxi para el montaje de 6 paneles Mitesco.

Standssäulen aus pulverbeschichtetem Stahl mit Standfuß aus pulverbeschichtetem Gusseisen zur Aufstellung von 6 Mitesco-Paneelen.

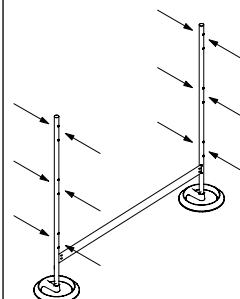

Grigio argento
Silver grey
Gris argenté
Gris plata
Silbergrau

Per pannelli For panels	Per pannelli For panels	Per pannelli For panels
L. 75 cm 7M6870-GA	L. 119 cm 7M6270-GA	L. 159 cm 7M6670-GA

Bianco opaco
Mat white
Blanc mat
Blanco mate
Mattweiß

Per pannelli For panels	Per pannelli For panels	Per pannelli For panels
L. 75 cm 7M6870-BO	L. 119 cm 7M6270-BO	L. 159 cm 7M6670-BO

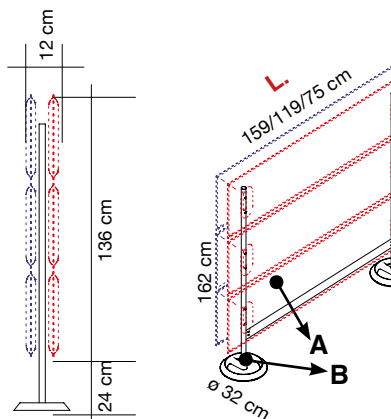

A	7M1008-XXXX o/or 7M1008BO-XXXX	L. 75 cm
B	7M6870-GA o/or 7M6870-BO	

o/or

A	7M1012-XXXX o/or 7M1012BO-XXXX	L. 119 cm
B	7M6270-GA o/or 7M6270-BO	

o/or

A	7M1016-XXXX o/or 7M1016BO-XXXX	L. 159 cm
B	7M6670-GA o/or 7M6670-BO	

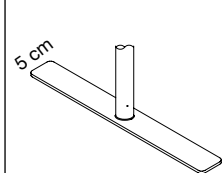

Dettaglio della base
Detail of the base
Détail de la base
Detaille de la base
Details der Basis

STRUTTURA MONOFRONTTE ONE-SIDED FRAME

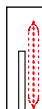

Struttura in acciaio verniciato con polveri epossidiche con basi in acciaio verniciato con polveri epossidiche per il montaggio di 2, 3 o 4 pannelli Mitesco.

Structure in powder-coated steel with bases in powder-coated steel to mount 2, 3 or 4 Mitesco panels.

Structure en acier peint époxy avec bases en acier peint époxy pour le montage de 2, 3 ou 4 panneaux Mitesco.

Estructura de acero recubierto epoxi con bases de acero recubierto epoxi para el montaje de 2, 3 o 4 paneles Mitesco.

Standsäulen aus pulverbeschichtetem Stahl mit Standfuß aus pulverbeschichtetem Stahl zur Aufstellung von 2, 3 oder 4 Mitesco-Paneeelen.

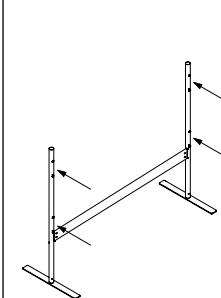

Grigio argento
Silver grey
Gris argenté
Gris plata
Silbergrau

Per pannelli
For panels
L. 75 cm
7M0850-GA

Per pannelli
For panels
L. 119 cm
7M0250-GA

Per pannelli
For panels
L. 159 cm
7M0650-GA

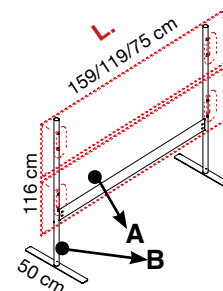
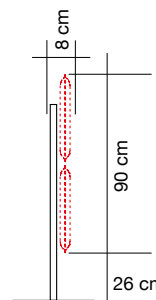

A 7M1008-XXXX o/or 7M1008BO-XXXX
B 7M0850-GA o/or 7M0850-BO **L. 75 cm**

o/or

A 7M1012-XXXX o/or 7M1012BO-XXXX
B 7M0250-GA o/or 7M0250-BO **L. 119 cm**

o/or

A 7M1016-XXXX o/or 7M1016BO-XXXX
B 7M0650-GA o/or 7M0650-BO **L. 159 cm**

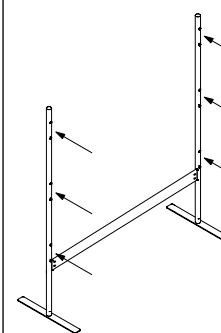

Grigio argento
Silver grey
Gris argenté
Gris plata
Silbergrau

Per pannelli
For panels
L. 75 cm
7M3850-GA

Per pannelli
For panels
L. 119 cm
7M3250-GA

Per pannelli
For panels
L. 159 cm
7M3650-GA

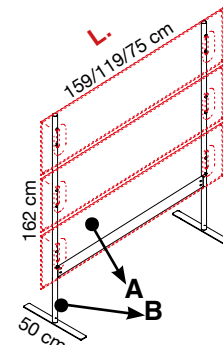
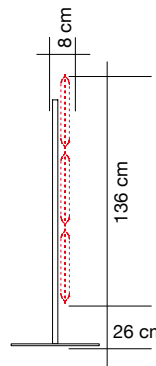

A 7M1008-XXXX o/or 7M1008BO-XXXX
B 7M3850-GA o/or 7M3850-BO **L. 75 cm**

o/or

A 7M1012-XXXX o/or 7M1012BO-XXXX
B 7M3250-GA o/or 7M3250-BO **L. 119 cm**

o/or

A 7M1016-XXXX o/or 7M1016BO-XXXX
B 7M3650-GA o/or 7M3650-BO **L. 159 cm**

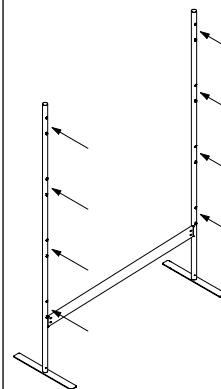

Grigio argento
Silver grey
Gris argenté
Gris plata
Silbergrau

Per pannelli
For panels
L. 75 cm
7M4850-GA

Per pannelli
For panels
L. 119 cm
7M4250-GA

Per pannelli
For panels
L. 159 cm
7M4650-GA

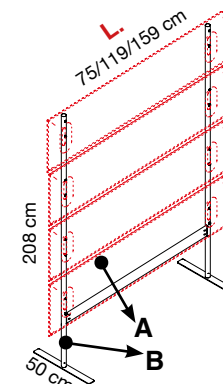
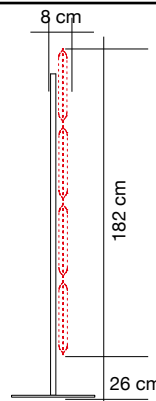

A 7M1008-XXXX o/or 7M1008BO-XXXX
B 7M4850-GA o/or 7M4850-BO **L. 75 cm**

o/or

A 7M1012-XXXX o/or 7M1012BO-XXXX
B 7M4250-GA o/or 7M4250-BO **L. 119 cm**

o/or

A 7M1016-XXXX o/or 7M1016BO-XXXX
B 7M4650-GA o/or 7M4650-BO **L. 159 cm**

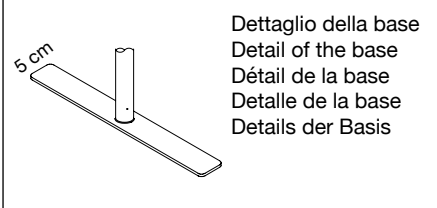

Dettaglio della base
Detail of the base
Détail de la base
Detalle de la base
Details der Basis

**STRUTTURA BIFRONTE
DOUBLE-SIDED FRAME**

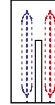

Dimension Codice/Code Prezzo/Price	Dimension Codice/Code Prezzo/Price	Dimension Codice/Code Prezzo/Price
--	--	--

Struttura in acciaio verniciato con polveri epossidiche con basi in acciaio verniciato con polveri epossidiche per il montaggio di **4, 6 o 8** pannelli Mitesco.

Structure in powder-coated steel with bases in powder-coated steel to mount **4, 6 or 8** Mitesco panels.

Structure en acier peint époxy avec bases en acier peint époxy pour le montage de **4, 6 ou 8** panneaux Mitesco.

Estructura de acero recubierto epoxi con bases de acero recubierto epoxi para el montaje de **4, 6 o 8** paneles Mitesco.

Standsäulen aus pulverbeschichtetem Stahl mit Standfuß aus pulverbeschichtetem Stahl zur Aufstellung von **4, 6 oder 8** Mitesco-Paneeelen.

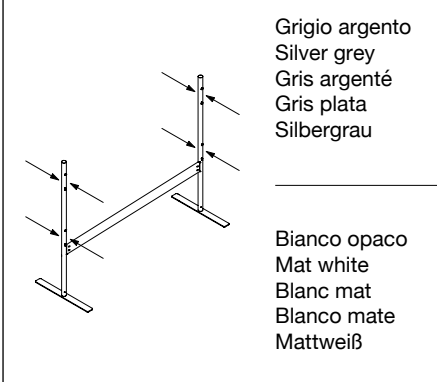

Grigio argento
Silver grey
Gris argenté
Gris plata
Silbergrau

Per pannelli For panels	Per pannelli For panels	Per pannelli For panels
L. 75 cm 7M2850-GA	L. 119 cm 7M2250-GA	L. 159 cm 7M2650-GA

Bianco opaco
Mat white
Blanc mat
Blanco mate
Mattweiß

Per pannelli For panels	Per pannelli For panels	Per pannelli For panels
L. 75 cm 7M2850-BO	L. 119 cm 7M2250-BO	L. 159 cm 7M2650-BO

A	7M1008-XXXX o/or 7M1008BO-XXXX	L. 75 cm
B	7M2250-GA o/or 7M2250-BO	
o/or		
A	7M1012-XXXX o/or 7M1012BO-XXXX	L. 119 cm
B	7M2250-GA o/or 7M2250-BO	
o/or		
A	7M1016-XXXX o/or 7M1016BO-XXXX	L. 159 cm
B	7M2650-GA o/or 7M2650-BO	

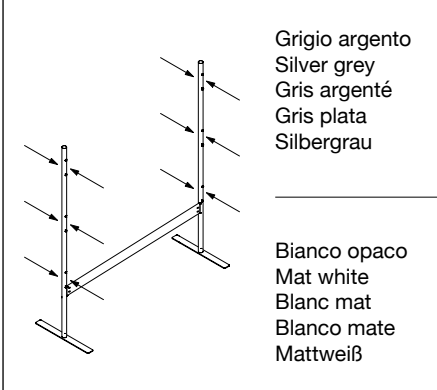

Grigio argento
Silver grey
Gris argenté
Gris plata
Silbergrau

Per pannelli For panels	Per pannelli For panels	Per pannelli For panels
L. 75 cm 7M6850-GA	L. 119 cm 7M6250-GA	L. 159 cm 7M6650-GA

Bianco opaco
Mat white
Blanc mat
Blanco mate
Mattweiß

Per pannelli For panels	Per pannelli For panels	Per pannelli For panels
L. 75 cm 7M6850-BO	L. 119 cm 7M6250-BO	L. 159 cm 7M6650-BO

A	7M1008-XXXX o/or 7M1008BO-XXXX	L. 75 cm
B	7M6850-GA o/or 7M6850-BO	
o/or		
A	7M1012-XXXX o/or 7M1012BO-XXXX	L. 119 cm
B	7M6250-GA o/or 7M6250-BO	
o/or		
A	7M1016-XXXX o/or 7M1016BO-XXXX	L. 159 cm
B	7M6650-GA o/or 7M6650-BO	

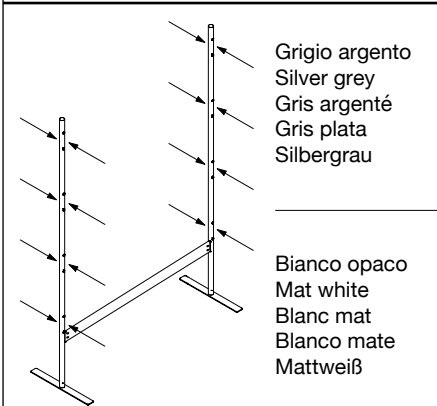

Grigio argento
Silver grey
Gris argenté
Gris plata
Silbergrau

Per pannelli For panels	Per pannelli For panels	Per pannelli For panels
L. 75 cm 7M8850-GA	L. 119 cm 7M8250-GA	L. 159 cm 7M8650-GA

Bianco opaco
Mat white
Blanc mat
Blanco mate
Mattweiß

Per pannelli For panels	Per pannelli For panels	Per pannelli For panels
L. 75 cm 7M8850-BO	L. 119 cm 7M8250-BO	L. 159 cm 7M8650-BO

A	7M1008-XXXX o/or 7M1008BO-XXXX	L. 75 cm
B	7M8850-GA o/or 7M8850-BO	
o/or		
A	7M1012-XXXX o/or 7M1012BO-XXXX	L. 119 cm
B	7M8250-GA o/or 7M8250-BO	
o/or		
A	7M1016-XXXX o/or 7M1016BO-XXXX	L. 159 cm
B	7M8650-GA o/or 7M8650-BO	

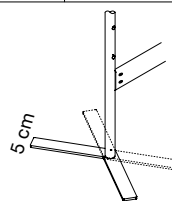

Dettaglio della base. La base può essere montata in due posizioni, interna o esterna.
Detail of the base. The base can be mounted in two positions, internal or external.

STRUTTURA MONOFRONTTE ONE-SIDED FRAME

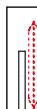

Struttura in acciaio verniciato con polveri epossidiche con basi in acciaio verniciato con polveri epossidiche per il montaggio di 2, 3 o 4 pannelli Mitesco.

Structure in powder-coated steel with bases in powder-coated steel to mount 2, 3 or 4 Mitesco panels.

Structure en acier peint époxy avec bases en acier peint époxy pour le montage de 2, 3 ou 4 panneaux Mitesco.

Estructura de acero recubierto epoxi con bases de acero recubierto epoxi para el montaje de 2, 3 o 4 paneles Mitesco.

Standsäulen aus pulverbeschichtetem Stahl mit Standfuß aus pulverbeschichtetem Stahl zur Aufstellung von 2, 3 oder 4 Mitesco-Paneeelen.

Dimension Codice/Code Prezzo/Price	Dimension Codice/Code Prezzo/Price	Dimension Codice/Code Prezzo/Price
--	--	--

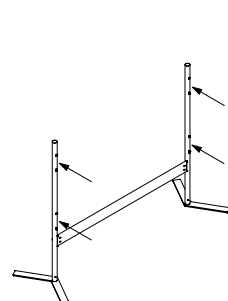

Grigio argento
Silver grey
Gris argenté
Gris plata
Silbergrau

Per pannelli For panels	Per pannelli For panels	Per pannelli For panels
L. 75 cm 7M0830-GA	L. 119 cm 7M0230-GA	L. 159 cm 7M0630-GA



Bianco opaco
Mat white
Blanc mat
Blanco mate
Mattweiß

Per pannelli For panels	Per pannelli For panels	Per pannelli For panels
L. 75 cm 7M0830-BO	L. 119 cm 7M0230-BO	L. 159 cm 7M0630-BO

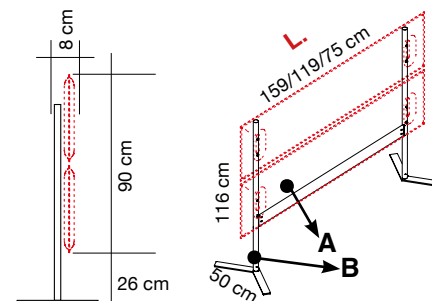

A	7M1008-XXXX o/or 7M1008BO-XXXX	L. 75 cm
B	7M0830-GA o/or 7M0830-BO	

o/or

A	7M1012-XXXX o/or 7M1012BO-XXXX	L. 119 cm
B	7M0230-GA o/or 7M0230-BO	

o/or

A	7M1016-XXXX o/or 7M1016BO-XXXX	L. 159 cm
B	7M0630-GA o/or 7M0630-BO	

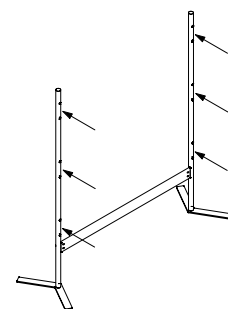

Grigio argento
Silver grey
Gris argenté
Gris plata
Silbergrau

Per pannelli For panels	Per pannelli For panels	Per pannelli For panels
L. 75 cm 7M3830-GA	L. 119 cm 7M3230-GA	L. 159 cm 7M3630-GA

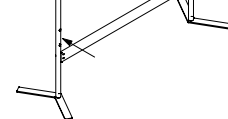

Bianco opaco
Mat white
Blanc mat
Blanco mate
Mattweiß

Per pannelli For panels	Per pannelli For panels	Per pannelli For panels
L. 75 cm 7M3830-BO	L. 119 cm 7M3230-BO	L. 159 cm 7M3630-BO

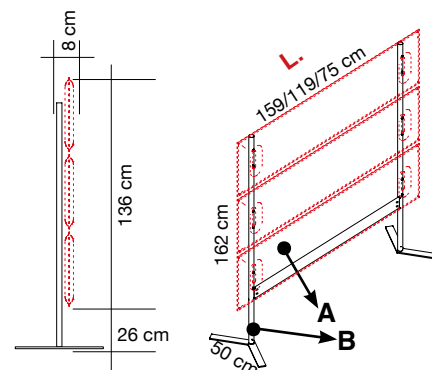

A	7M1008-XXXX o/or 7M1008BO-XXXX	L. 75 cm
B	7M3830-GA o/or 7M3830-BO	

o/or

A	7M1012-XXXX o/or 7M1012BO-XXXX	L. 119 cm
B	7M3230-GA o/or 7M3230-BO	

o/or

A	7M1016-XXXX o/or 7M1016BO-XXXX	L. 159 cm
B	7M3630-GA o/or 7M3630-BO	

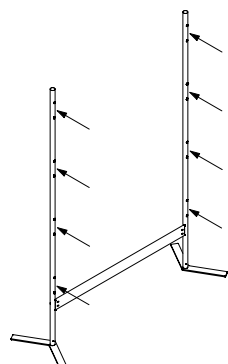

Grigio argento
Silver grey
Gris argenté
Gris plata
Silbergrau

Per pannelli For panels	Per pannelli For panels	Per pannelli For panels
L. 75 cm 7M4830-GA	L. 119 cm 7M4230-GA	L. 159 cm 7M4630-GA

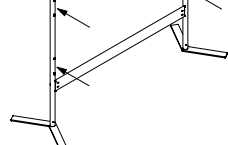

Bianco opaco
Mat white
Blanc mat
Blanco mate
Mattweiß

Per pannelli For panels	Per pannelli For panels	Per pannelli For panels
L. 75 cm 7M4830-BO	L. 119 cm 7M4230-BO	L. 159 cm 7M4630-BO

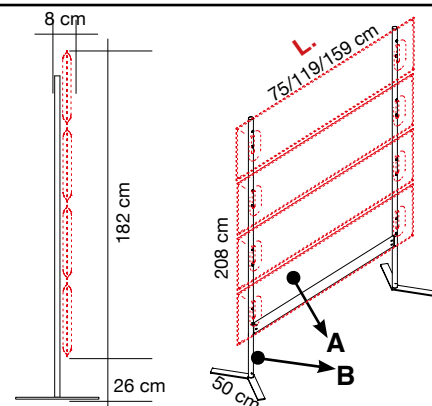

A	7M1008-XXXX o/or 7M1008BO-XXXX	L. 75 cm
B	7M4830-GA o/or 7M4830-BO	

o/or

A	7M1012-XXXX o/or 7M1012BO-XXXX	L. 119 cm
B	7M4230-GA o/or 7M4230-BO	

o/or

A	7M1016-XXXX o/or 7M1016BO-XXXX	L. 159 cm
B	7M4630-GA o/or 7M4630-BO	

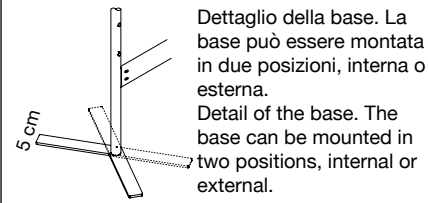

Dettaglio della base. La base può essere montata in due posizioni, interna o esterna.
Detail of the base. The base can be mounted in two positions, internal or external.

STRUTTURA BIFRONTE DOUBLE-SIDED FRAME

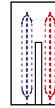

Struttura in acciaio verniciato con polveri epossidiche con basi in acciaio verniciato con polveri epossidiche per il montaggio di 4, 6 o 8 pannelli Mitesco.

Structure in powder-coated steel with bases in powder-coated steel to mount 4, 6 or 8 Mitesco panels.

Structure en acier peint époxy avec bases en acier peint époxy pour le montage de 4, 6 ou 8 panneaux Mitesco.

Estructura de acero recubierto epoxi con bases de acero recubierto epoxi para el montaje de 4, 6 o 8 paneles Mitesco.

Standssäulen aus pulverbeschichtetem Stahl mit Standfuß aus pulverbeschichtetem Stahl zur Aufstellung von 4, 6 oder 8 Mitesco-Paneelen.

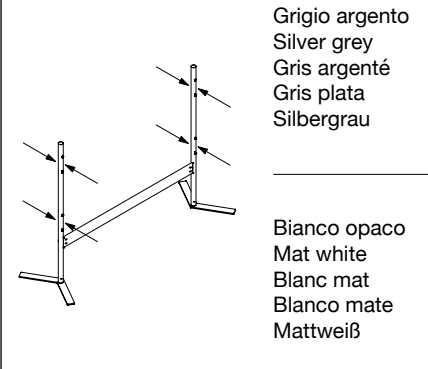

Grigio argento
Silver grey
Gris argenté
Gris plata
Silbergrau

Dimension Codice/Code Prezzo/Price	Dimension Codice/Code Prezzo/Price	Dimension Codice/Code Prezzo/Price
Per pannelli For panels L. 75 cm 7M2830-GA	Per pannelli For panels L. 119 cm 7M2230-GA	Per pannelli For panels L. 159 cm 7M2630-GA

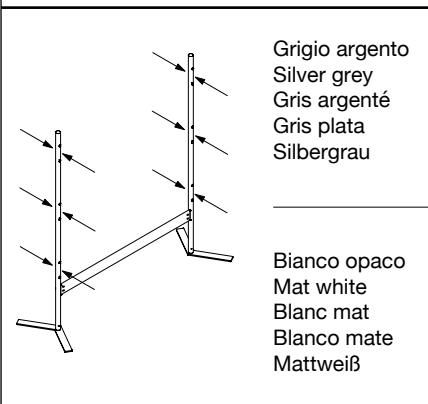

Bianco opaco
Mat white
Blanc mat
Blanco mate
Mattweiß

Dimension Codice/Code Prezzo/Price	Dimension Codice/Code Prezzo/Price	Dimension Codice/Code Prezzo/Price
Per pannelli For panels L. 75 cm 7M2830-BO	Per pannelli For panels L. 119 cm 7M2230-BO	Per pannelli For panels L. 159 cm 7M2630-BO

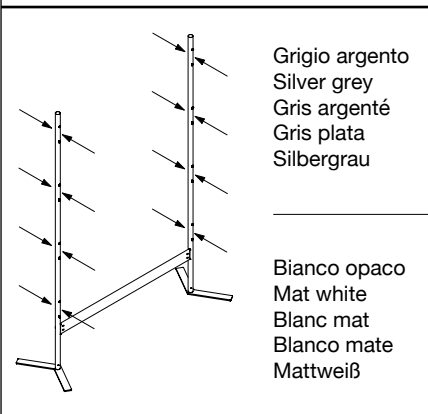

Grigio argento
Silver grey
Gris argenté
Gris plata
Silbergrau

Dimension Codice/Code Prezzo/Price	Dimension Codice/Code Prezzo/Price	Dimension Codice/Code Prezzo/Price
Per pannelli For panels L. 75 cm 7M8830-GA	Per pannelli For panels L. 119 cm 7M8230-GA	Per pannelli For panels L. 159 cm 7M8630-GA

Bianco opaco
Mat white
Blanc mat
Blanco mate
Mattweiß

Dimension Codice/Code Prezzo/Price	Dimension Codice/Code Prezzo/Price	Dimension Codice/Code Prezzo/Price
Per pannelli For panels L. 75 cm 7M8830-BO	Per pannelli For panels L. 119 cm 7M8230-BO	Per pannelli For panels L. 159 cm 7M8630-BO

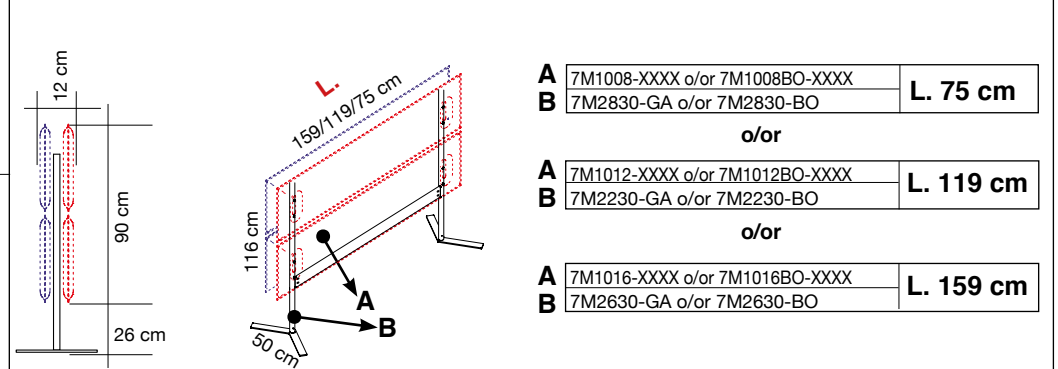

A	7M1008-XXXX o/or 7M1008BO-XXXX	L. 75 cm
B	7M2830-GA o/or 7M2830-BO	

o/or

A	7M1012-XXXX o/or 7M1012BO-XXXX	L. 119 cm
B	7M2230-GA o/or 7M2230-BO	

o/or

A	7M1016-XXXX o/or 7M1016BO-XXXX	L. 159 cm
B	7M2630-GA o/or 7M2630-BO	

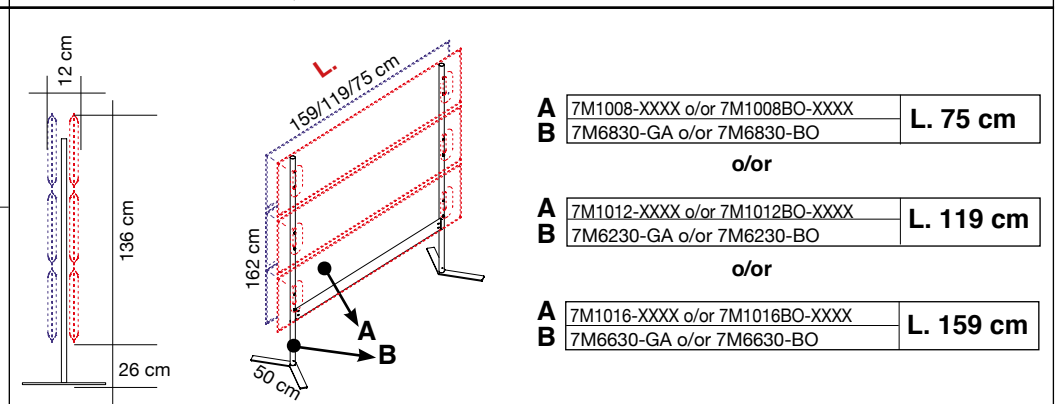

A	7M1008-XXXX o/or 7M1008BO-XXXX	L. 75 cm
B	7M6830-GA o/or 7M6830-BO	

o/or

A	7M1012-XXXX o/or 7M1012BO-XXXX	L. 119 cm
B	7M6230-GA o/or 7M6230-BO	

o/or

A	7M1016-XXXX o/or 7M1016BO-XXXX	L. 159 cm
B	7M6630-GA o/or 7M6630-BO	

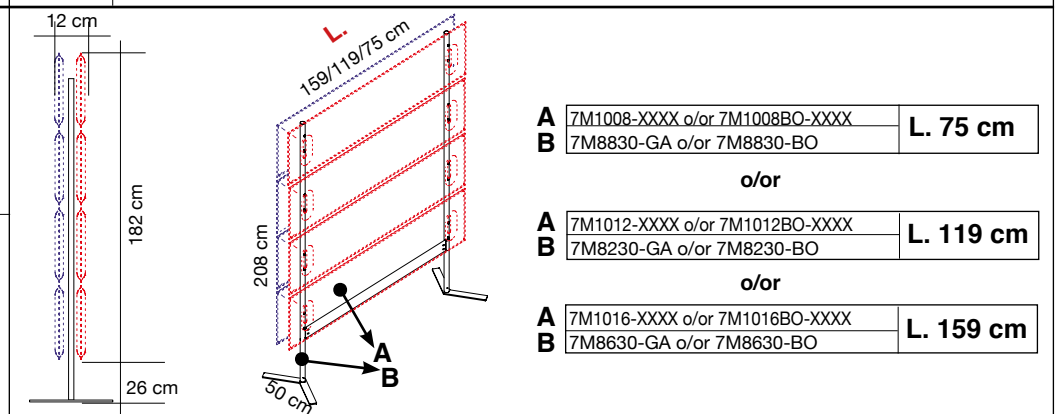

A	7M1008-XXXX o/or 7M1008BO-XXXX	L. 75 cm
B	7M8830-GA o/or 7M8830-BO	

o/or

A	7M1012-XXXX o/or 7M1012BO-XXXX	L. 119 cm
B	7M8230-GA o/or 7M8230-BO	

o/or

A	7M1016-XXXX o/or 7M1016BO-XXXX	L. 159 cm
B	7M8630-GA o/or 7M8630-BO	

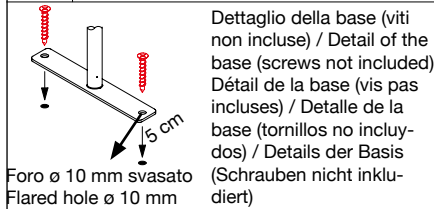

STRUTTURA MONOFRONTE ONE-SIDED FRAME



Struttura in acciaio verniciato con polveri epossidiche con basi in acciaio verniciato con polveri epossidiche per il montaggio di 2, 3 o 4 pannelli Mitesco.

Structure in powder-coated steel with bases in powder-coated steel to mount 2, 3 or 4 Mitesco panels.

Structure en acier peint époxy avec bases en acier peint époxy pour le montage de 2, 3 ou 4 panneaux Mitesco.

Estructura de acero recubierto epoxi con bases de acero recubierto epoxi para el montaje de 2, 3 o 4 paneles Mitesco.

Standsäulen aus pulverbeschichtetem Stahl mit Standfuß aus pulverbeschichtetem Stahl zur Aufstellung von 2, 3 oder 4 Mitesco-Paneeelen.

Dimension Codice/Code Prezzo/Price	Dimension Codice/Code Prezzo/Price	Dimension Codice/Code Prezzo/Price
--	--	--

<p>Grigio argento Silver grey Gris argenté Gris plata Silbergrau</p>	Per pannelli For panels L. 75 cm 7M0825-GA	Per pannelli For panels L. 119 cm 7M0225-GA	Per pannelli For panels L. 159 cm 7M0625-GA
	Per pannelli For panels L. 75 cm 7M0825-BO	Per pannelli For panels L. 119 cm 7M0225-BO	Per pannelli For panels L. 159 cm 7M0625-BO
<p>Bianco opaco Mat white Blanc mat Blanco mate Mattweiß</p>			

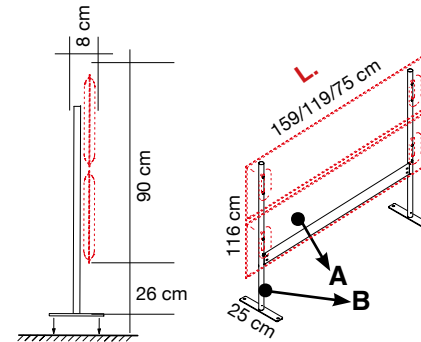

A	7M1008-XXXX o/or 7M1008BO-XXXX	L. 75 cm
B	7M0825-GA o/or 7M0825-BO	

o/or

A	7M1012-XXXX o/or 7M1012BO-XXXX	L. 119 cm
B	7M0225-GA o/or 7M0225-BO	

o/or

A	7M1016-XXXX o/or 7M1016BO-XXXX	L. 159 cm
B	7M0625-GA o/or 7M0625-BO	

<p>Grigio argento Silver grey Gris argenté Gris plata Silbergrau</p>	Per pannelli For panels L. 75 cm 7M3825-GA	Per pannelli For panels L. 119 cm 7M3225-GA	Per pannelli For panels L. 159 cm 7M3625-GA
	Per pannelli For panels L. 75 cm 7M3825-BO	Per pannelli For panels L. 119 cm 7M3225-BO	Per pannelli For panels L. 159 cm 7M3625-BO
<p>Bianco opaco Mat white Blanc mat Blanco mate Mattweiß</p>			

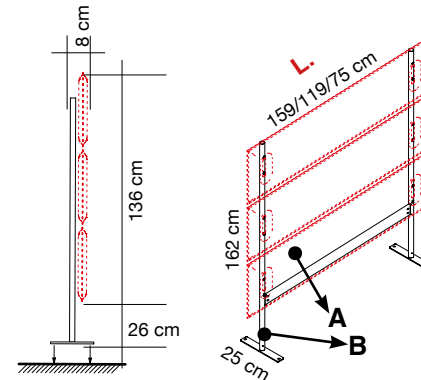

A	7M1008-XXXX o/or 7M1008BO-XXXX	L. 75 cm
B	7M3825-GA o/or 7M3825-BO	

o/or

A	7M1012-XXXX o/or 7M1012BO-XXXX	L. 119 cm
B	7M3225-GA o/or 7M3225-BO	

o/or

A	7M1016-XXXX o/or 7M1016BO-XXXX	L. 159 cm
B	7M3625-GA o/or 7M3625-BO	

<p>Grigio argento Silver grey Gris argenté Gris plata Silbergrau</p>	Per pannelli For panels L. 75 cm 7M4825-GA	Per pannelli For panels L. 119 cm 7M4225-GA	Per pannelli For panels L. 159 cm 7M4625-GA
	Per pannelli For panels L. 75 cm 7M4825-BO	Per pannelli For panels L. 119 cm 7M4225-BO	Per pannelli For panels L. 159 cm 7M4625-BO
<p>Bianco opaco Mat white Blanc mat Blanco mate Mattweiß</p>			

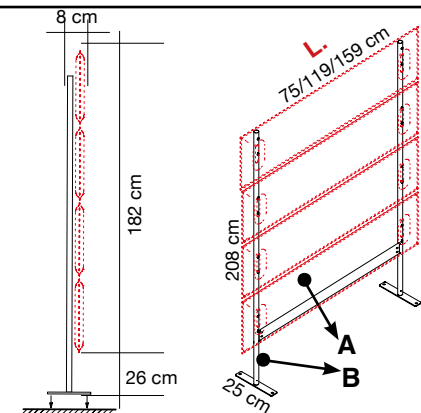

A	7M1008-XXXX o/or 7M1008BO-XXXX	L. 75 cm
B	7M4825-GA o/or 7M4825-BO	

o/or

A	7M1012-XXXX o/or 7M1012BO-XXXX	L. 119 cm
B	7M4225-GA o/or 7M4225-BO	

o/or

A	7M1016-XXXX o/or 7M1016BO-XXXX	L. 159 cm
B	7M4625-GA o/or 7M4625-BO	

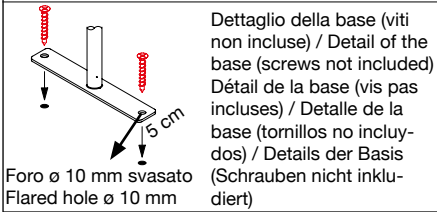

**STRUTTURA BIFRONTTE
DOUBLE-SIDED FRAME**

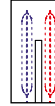

Struttura in acciaio verniciato con polveri epossidiche con basi in acciaio verniciato con polveri epossidiche per il montaggio di **4, 6 o 8** pannelli Mitesco.

Structure in powder-coated steel with bases in powder-coated steel to mount **4, 6 or 8** Mitesco panels.

Structure en acier peint époxy avec bases en acier peint époxy pour le montage de **4, 6 ou 8** panneaux Mitesco.

Estructura de acero recubierto epoxi con bases de acero recubierto epoxi para el montaje de **4, 6 o 8** paneles Mitesco.

Standsäulen aus pulverbeschichtetem Stahl mit Standfuß aus pulverbeschichtetem Stahl zur Aufstellung von **4, 6 oder 8** Mitesco-Paneelen.

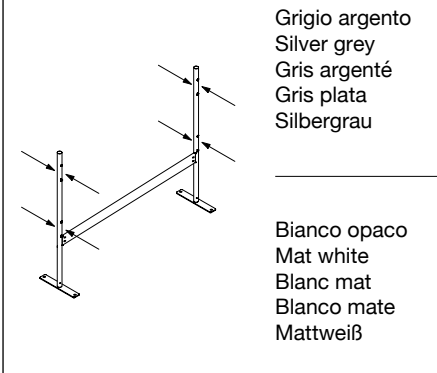

Dimension Codice/Code Prezzo/Price	Dimension Codice/Code Prezzo/Price	Dimension Codice/Code Prezzo/Price
Per pannelli For panels L. 75 cm 7M2825-GA	Per pannelli For panels L. 119 cm 7M2225-GA	Per pannelli For panels L. 159 cm 7M2625-GA
Per pannelli For panels L. 75 cm 7M2825-BO	Per pannelli For panels L. 119 cm 7M2225-BO	Per pannelli For panels L. 159 cm 7M2625-BO

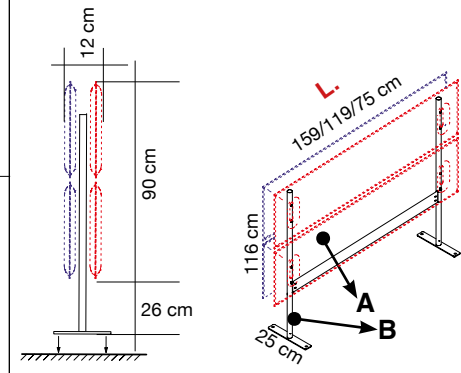

A	7M1008-XXXX o/or 7M1008BO-XXXX	L. 75 cm
B	7M2825-GA o/or 7M2825-BO	
o/or		
A	7M1012-XXXX o/or 7M1012BO-XXXX	L. 119 cm
B	7M2225-GA o/or 7M2225-BO	
o/or		
A	7M1016-XXXX o/or 7M1016BO-XXXX	L. 159 cm
B	7M2625-GA o/or 7M2625-BO	

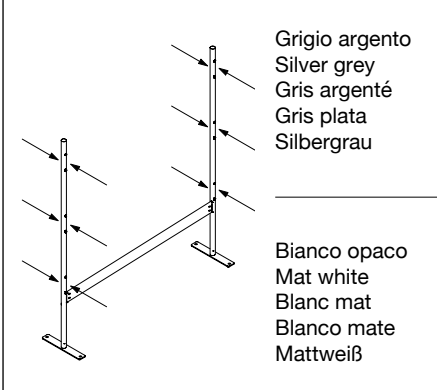

Dimension Codice/Code Prezzo/Price	Dimension Codice/Code Prezzo/Price	Dimension Codice/Code Prezzo/Price
Per pannelli For panels L. 75 cm 7M6825-GA	Per pannelli For panels L. 119 cm 7M6225-GA	Per pannelli For panels L. 159 cm 7M6625-GA
Per pannelli For panels L. 75 cm 7M6825-BO	Per pannelli For panels L. 119 cm 7M6225-BO	Per pannelli For panels L. 159 cm 7M6625-BO

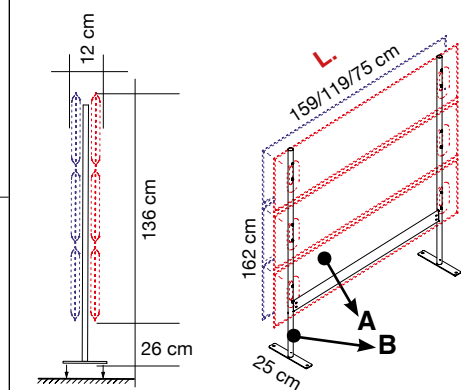

A	7M1008-XXXX o/or 7M1008BO-XXXX	L. 75 cm
B	7M6825-GA o/or 7M6825-BO	
o/or		
A	7M1012-XXXX o/or 7M1012BO-XXXX	L. 119 cm
B	7M6225-GA o/or 7M6225-BO	
o/or		
A	7M1016-XXXX o/or 7M1016BO-XXXX	L. 159 cm
B	7M6625-GA o/or 7M6625-BO	

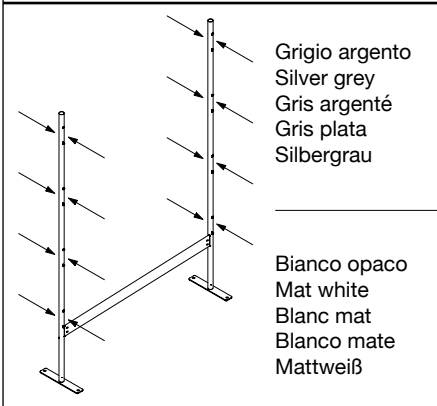

Dimension Codice/Code Prezzo/Price	Dimension Codice/Code Prezzo/Price	Dimension Codice/Code Prezzo/Price
Per pannelli For panels L. 75 cm 7M8825-GA	Per pannelli For panels L. 119 cm 7M8225-GA	Per pannelli For panels L. 159 cm 7M8625-GA
Per pannelli For panels L. 75 cm 7M8825-BO	Per pannelli For panels L. 119 cm 7M8225-BO	Per pannelli For panels L. 159 cm 7M8625-BO

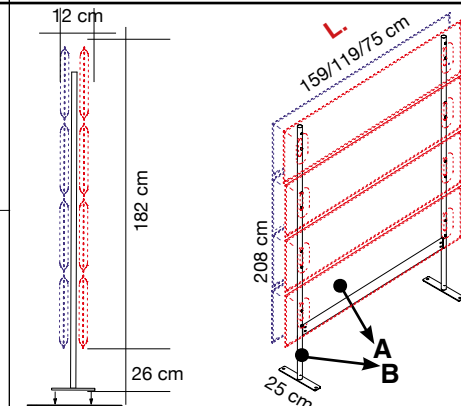

A	7M1008-XXXX o/or 7M1008BO-XXXX	L. 75 cm
B	7M8825-GA o/or 7M8825-BO	
o/or		
A	7M1012-XXXX o/or 7M1012BO-XXXX	L. 119 cm
B	7M8225-GA o/or 7M8225-BO	
o/or		
A	7M1016-XXXX o/or 7M1016BO-XXXX	L. 159 cm
B	7M8625-GA o/or 7M8625-BO	

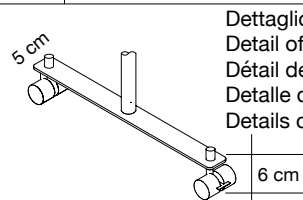

Dettaglio della base
Detail of the base
Détail de la base
Detalle de la base
Details der Basis

STRUTTURA MONOFRONTALE ONE-SIDED FRAME

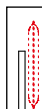

Struttura e basi in acciaio verniciato con polveri epossidiche, ruote in tecnopolimero (2 con freno e 2 senza) per il montaggio di 2, 3 o 4 pannelli Mitesco.

Frame and bases in powder-coated steel, polymer castors (2 with and 2 without brakes), to mount 2, 3 or 4 Mitesco panels.

Structure et bases acier peint époxy, roulettes polymère (2 avec freins et 2 sans) pour montage de 2, 3 ou 4 panneaux Mitesco.

Estructura y bases de acero recubierto epoxi, ruedas en polimero (2 con freno y 2 sin) para el montaje de 2, 3 o 4 paneles Mitesco.

Standsäulen und Standfuß aus pulverbeschichtetem Stahl, Rollen aus Technopolymer (2 davon feststellbar) zur Aufstellung von 2, 3 oder 6 Mitesco-Paneelen.

Dimension Codice/Code Prezzo/Price	Dimension Codice/Code Prezzo/Price	Dimension Codice/Code Prezzo/Price
--	--	--

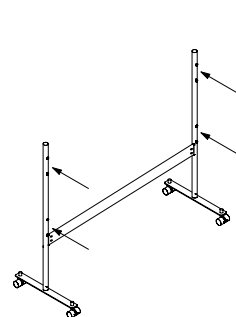

Grigio argento
Silver grey
Gris argenté
Gris plata
Silbergrau

Per pannelli For panels	Per pannelli For panels	Per pannelli For panels
L. 75 cm 7M0860-RGA	L. 119 cm 7M0260-RGA	L. 159 cm 7M0660-RGA

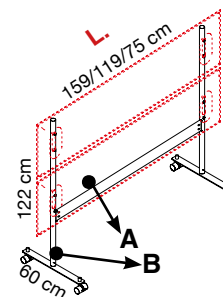
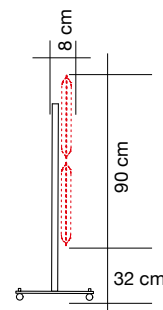

A	7M1008-XXXX o/or 7M1008BO-XXXX	L. 75 cm
B	7M0860-RGA o/or 7M0860-RBO	

o/or

A	7M1012-XXXX o/or 7M1012BO-XXXX	L. 119 cm
B	7M0260-RGA o/or 7M0260-RBO	

o/or

A	7M1016-XXXX o/or 7M1016BO-XXXX	L. 159 cm
B	7M0660-RGA o/or 7M0660-RBO	

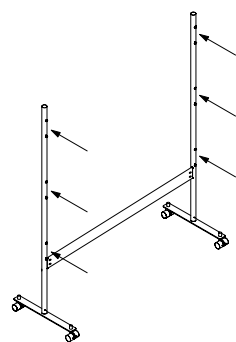

Grigio argento
Silver grey
Gris argenté
Gris plata
Silbergrau

Per pannelli For panels	Per pannelli For panels	Per pannelli For panels
L. 75 cm 7M3860-RGA	L. 119 cm 7M3260-RGA	L. 159 cm 7M3660-RGA

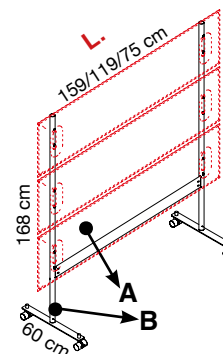
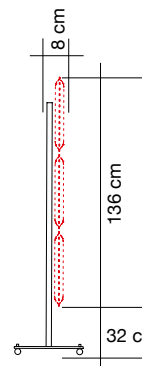

A	7M1008-XXXX o/or 7M1008BO-XXXX	L. 75 cm
B	7M3860-RGA o/or 7M3860-RBO	

o/or

A	7M1012-XXXX o/or 7M1012BO-XXXX	L. 119 cm
B	7M3260-RGA o/or 7M3260-RBO	

o/or

A	7M1016-XXXX o/or 7M1016BO-XXXX	L. 159 cm
B	7M3660-RGA o/or 7M3660-RBO	

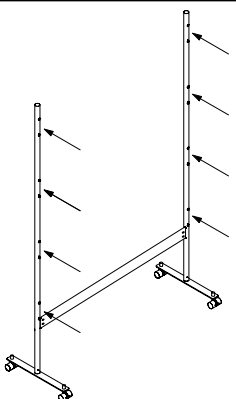

Grigio argento
Silver grey
Gris argenté
Gris plata
Silbergrau

Per pannelli For panels	Per pannelli For panels	Per pannelli For panels
L. 75 cm 7M4860-RGA	L. 119 cm 7M4260-RGA	L. 159 cm 7M4660-RGA

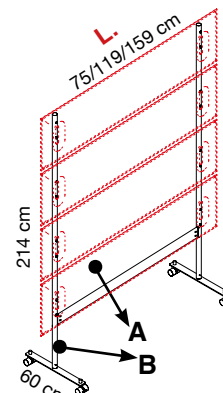
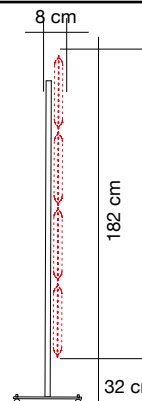

A	7M1008-XXXX o/or 7M1008BO-XXXX	L. 75 cm
B	7M4860-RGA o/or 7M4860-RBO	

o/or

A	7M1012-XXXX o/or 7M1012BO-XXXX	L. 119 cm
B	7M4260-RGA o/or 7M4260-RBO	

o/or

A	7M1016-XXXX o/or 7M1016BO-XXXX	L. 159 cm
B	7M4660-RGA o/or 7M4660-RBO	

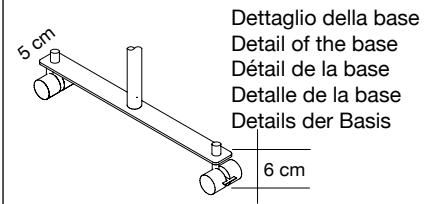

Dettaglio della base
Detail of the base
Détail de la base
Detaille der Basis

**STRUTTURA BIFRONTTE
DOUBLE-SIDED FRAME**

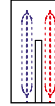

Struttura e basi in acciaio verniciato con polveri epossidiche, ruote in tecnopolimero (2 con freno e 2 senza) per il montaggio di 4, 6 o 8 pannelli Mitesco.

Frame and bases in powder-coated steel, polymer castors (2 with and 2 without brakes), to mount 4, 6 or 8 Mitesco panels.

Structure et bases acier peint époxy, roulettes polymère (2 avec freins et 2 sans) pour montage de 4, 6 ou 8 panneaux Mitesco.

Estructura y bases de acero recubierto epoxi, ruedas en polimero (2 con freno y 2 sin) para montaje de 4, 6 o 8 paneles Mitesco

Standsäulen und Standfuß aus pulverbeschichtetem Stahl, Rollen aus Technopolymer (2 davon feststellbar) zur Aufstellung von 4, 6 oder 8 Mitesco-Paneelen.

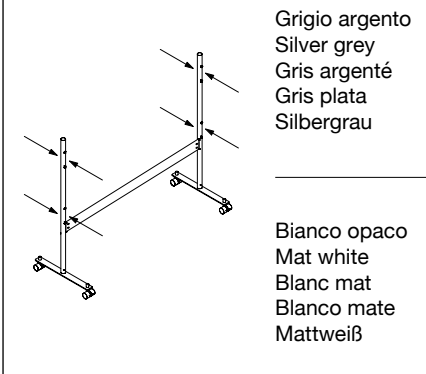

Grigio argento
Silver grey
Gris argenté
Gris plata
Silbergrau

Dimension Codice/Code Prezzo/Price	Dimension Codice/Code Prezzo/Price	Dimension Codice/Code Prezzo/Price
Per pannelli For panels L. 75 cm 7M2860-RGA	Per pannelli For panels L. 119 cm 7M2260-RGA	Per pannelli For panels L. 159 cm 7M2660-RGA

Bianco opaco
Mat white
Blanc mat
Blanco mate
Mattweiß

Per pannelli For panels L. 75 cm 7M2860-RBO	Per pannelli For panels L. 119 cm 7M2260-RBO	Per pannelli For panels L. 159 cm 7M2660-RBO
---	--	--

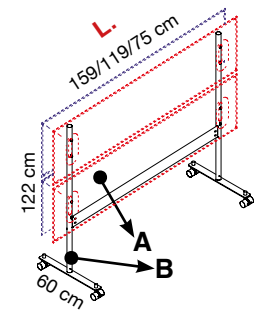
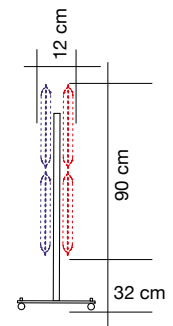

A	7M1008-XXXX o/or 7M1008BO-XXXX	L. 75 cm
B	7M2860-RGA o/or 7M2860-RBO	
o/or		
A	7M1012-XXXX o/or 7M1012BO-XXXX	L. 119 cm
B	7M2260-RGA o/or 7M2260-RBO	
o/or		
A	7M1016-XXXX o/or 7M1016BO-XXXX	L. 159 cm
B	7M2660-RGA o/or 7M2660-RBO	

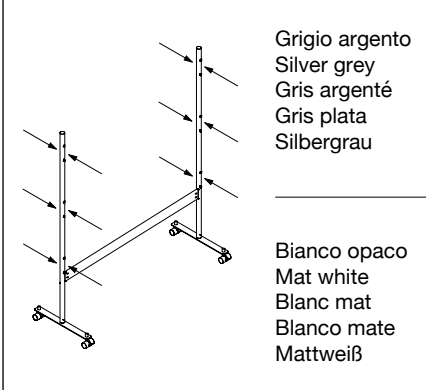

Grigio argento
Silver grey
Gris argenté
Gris plata
Silbergrau

Per pannelli For panels L. 75 cm 7M6860-RGA	Per pannelli For panels L. 119 cm 7M6260-RGA	Per pannelli For panels L. 159 cm 7M6660-RGA
---	--	--

Bianco opaco
Mat white
Blanc mat
Blanco mate
Mattweiß

Per pannelli For panels L. 75 cm 7M6860-RBO	Per pannelli For panels L. 119 cm 7M6260-RBO	Per pannelli For panels L. 159 cm 7M6660-RBO
---	--	--

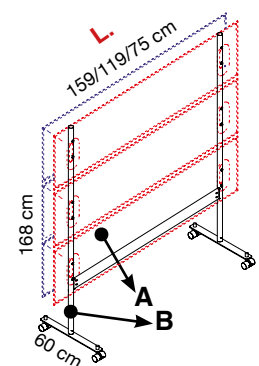
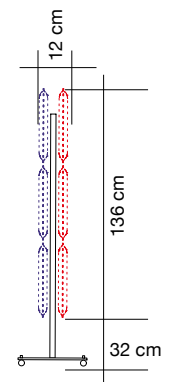

A	7M1008-XXXX o/or 7M1008BO-XXXX	L. 75 cm
B	7M6860-RGA o/or 7M6860-RBO	
o/or		
A	7M1012-XXXX o/or 7M1012BO-XXXX	L. 119 cm
B	7M6260-RGA o/or 7M6260-RBO	
o/or		
A	7M1016-XXXX o/or 7M1016BO-XXXX	L. 159 cm
B	7M6660-RGA o/or 7M6660-RBO	

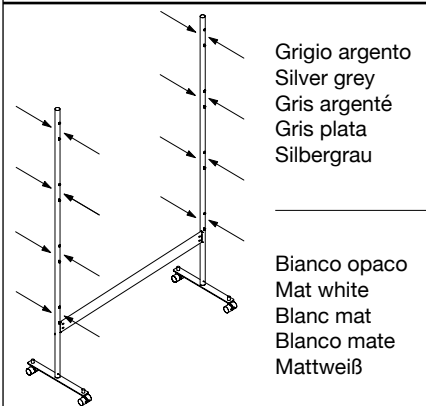

Grigio argento
Silver grey
Gris argenté
Gris plata
Silbergrau

Per pannelli For panels L. 75 cm 7M8860-RGA	Per pannelli For panels L. 119 cm 7M8260-RGA	Per pannelli For panels L. 159 cm 7M8660-RGA
---	--	--

Bianco opaco
Mat white
Blanc mat
Blanco mate
Mattweiß

Per pannelli For panels L. 75 cm 7M8860-RBO	Per pannelli For panels L. 119 cm 7M8260-RBO	Per pannelli For panels L. 159 cm 7M8660-RBO
---	--	--

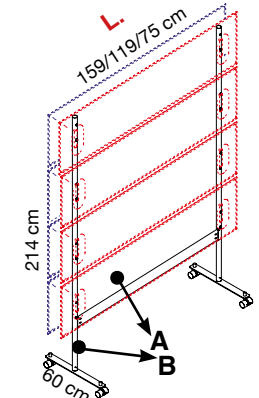
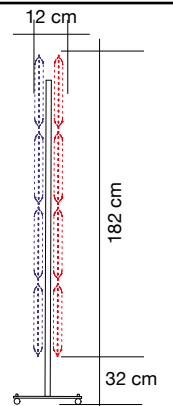

A	7M1008-XXXX o/or 7M1008BO-XXXX	L. 75 cm
B	7M8860-RGA o/or 7M8860-RBO	
o/or		
A	7M1012-XXXX o/or 7M1012BO-XXXX	L. 119 cm
B	7M8260-RGA o/or 7M8260-RBO	
o/or		
A	7M1016-XXXX o/or 7M1016BO-XXXX	L. 159 cm
B	7M8660-RGA o/or 7M8660-RBO	

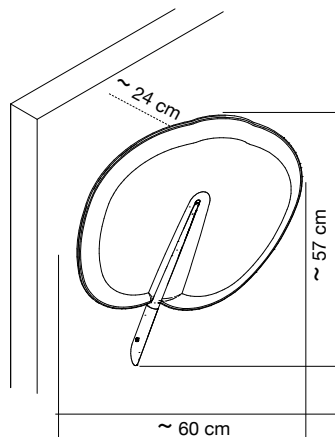

Colore
Colour

Bianco
White
Blanc
0012

Verde chiaro
Light green
Vert clair
7004

Grigio scuro
Dark grey
Gris foncé
8007

Codice/Code
Prezzo/Price

7LA1/CL-0012

7LA1/CL-7004

7LA1/CL-8007

Pannello orientabile con imbottitura interna in poliestere a **densità variabile** Snowsound® Technology. Rivestimento esterno in tessuto di poliestere Trevira CS®. Completo di attacco in metallo cromato per fissaggio a parete e a soffitto.

Adjustable panel with **variable density** polyester internal padding Snowsound® Technology. External polyester covering in Trevira CS® fabric. Equipped with chrome-plated metal plate for wall or ceiling fixing.

Panneau orientable avec rembourrage interne en polyester à **densité variable** Snowsound® Technology. Revêtement externe en tissu de polyester Trevira CS®.

Fourni avec connexion métallique chromée pour montage mural ou a plafond.

Panel orientable con acolchado interior de poliéster de **densidad variable** Snowsound® Technology. Revestimiento exterior en tejido de poliéster Trevira CS®. Se completa con placa metálica cromada para montaje en pared o techo.

Neigbares Akustikpaneel, innen mit Polyester in **unterschiedlicher Dichte** unter Verwendung der Snowsound®-Technologie gepolstert. Oberfläche aus Polyesterstoff Trevira CS®. Inklusive Halterung aus verchromtem Metall für die Wand- oder Deckenmontage.

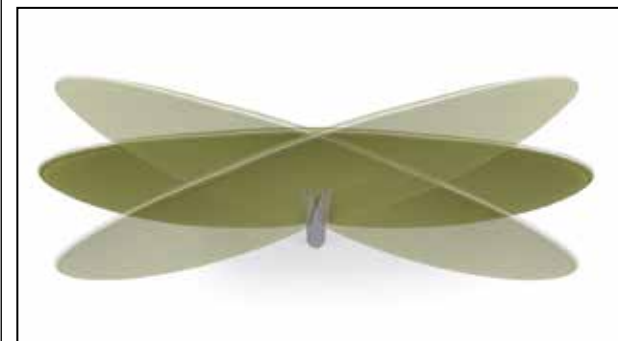

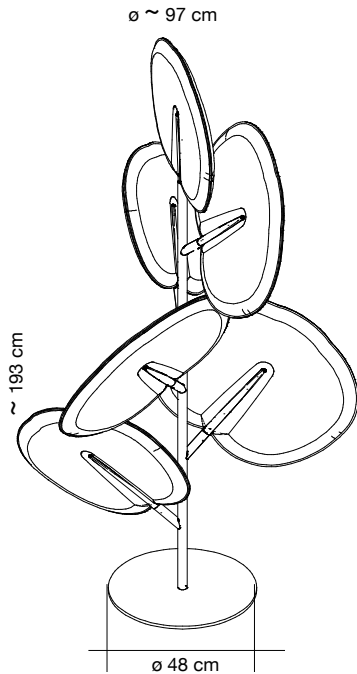

Colore
Colour

Bianco
White
Blanc
0012

Verde chiaro
Light green
Vert clair
7004

Grigio scuro
Dark grey
Gris foncé
8007

Codice/Code
Prezzo/Price

7LT6/CL-0012

7LT6/CL-7004

7LT6/CL-8007

Struttura in metallo cromato con base in acciaio verniciato con polveri epossidiche completo di 6 pannelli orientabili con imbottitura interna in poliester a **densità variabile** Snowsound® Technology. Rivestimento esterno in tessuto di poliester Trevira CS®.

Structure in chrome-plated metal with powder-coated steel base with 6 adjustable panels composed of **variable density** polyester internal padding Snowsound® Technology. External polyester covering in Trevira CS® fabric.

Structure en metal chromé avec base en acier peint epoxy avec 6 panneaux orientables avec rembourrage interne en polyester à **densité variable** Snowsound® Technology. Revêtement externe en tissu de polyester Trevira CS®.

Estructura de metal cromado con base de acero recubierto epoxy con 6 panels orientables con acolchado interior de poliéster de **densidad variable** Snowsound® Technology. Revestimiento exterior en tejido de poliéster Trevira CS®.

Standsäule aus verchromtem Metall mit Standfuß aus pulverbeschichtetem Stahl, mit 6 neigbaren Akustikpaneelen, innen mit Polyester in **unterschiedlicher Dichte** unter Verwendung der Snowsound®-Technologie gepolstert. Oberfläche aus Polyesterstoff Trevira CS®.

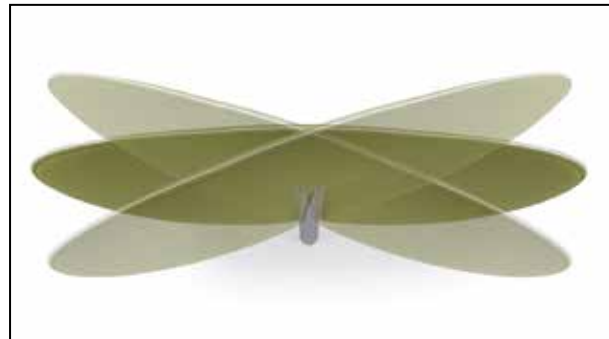

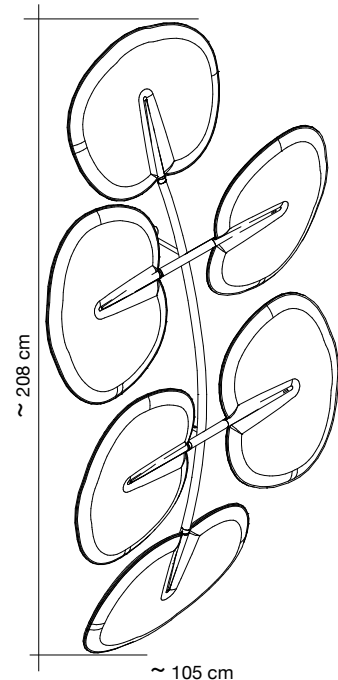

Colore
Colour

Bianco
White
Blanc
0012

Codice/Code
Prezzo/Price

7LW6/CL-0012

Struttura in metallo cromato per fissaggio a parete o a soffitto completa di 6 pannelli orientabili con imbottitura interna in poliester a **densità variabile** Snowsound® Technology. Rivestimento esterno in tessuto di poliester Trevira CS®.

Structure in chrome-plated metal for wall or ceiling fixing with 6 adjustable panels composed of **variable density** polyester internal padding Snowsound® Technology. External polyester covering in Trevira CS® fabric.

Structure en metal chromé pour montage mural ou à plafond avec 6 panneaux orientables avec rembourrage interne en polyester à **densité variable** Snowsound® Technology. Revêtement externe en tissu de polyester Trevira CS®.

Estructura de metal cromado para montaje en pared o techo con 6 paneles orientables con acolchado interior de poliéster de **densidad variable** Snowsound® Technology. Revestimiento exterior en tejido de poliéster Trevira CS®.

Halterung aus verchromtem Metall für die Wand- oder Deckenmontage mit 6 neigbaren Akustikpaneelen, innen mit Polyester in **unterschiedlicher Dichte** unter Verwendung der Snowsound®-Technologie gepolstert. Oberfläche aus Polyesterstoff Trevira CS®.

Verde chiaro
Light green
Vert clair
7004

7LW6/CL-7004

Grigio scuro
Dark grey
Gris foncé
8007

7LW6/CL-8007

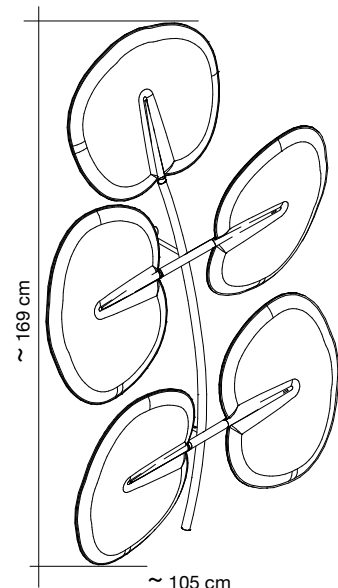

Colore
Colour

Bianco
White
Blanc
0012

Codice/Code
Prezzo/Price

7LW5/CL-0012

Struttura in metallo cromato per fissaggio a parete o a soffitto completa di 5 pannelli orientabili con imbottitura interna in poliester a **densità variabile** Snowsound® Technology. Rivestimento esterno in tessuto di poliester Trevira CS®.

Structure in chrome-plated metal for wall or ceiling fixing with 5 adjustable panels composed of **variable density** polyester internal padding Snowsound® Technology. External polyester covering in Trevira CS® fabric.

Structure en metal chromé pour montage mural ou à plafond avec 5 panneaux orientables avec rembourrage interne en polyester à **densité variable** Snowsound® Technology. Revêtement externe en tissu de polyester Trevira CS®.

Estructura de metal cromado para montaje en pared o techo con 5 paneles orientables con acolchado interior de poliéster de **densidad variable** Snowsound® Technology. Revestimiento exterior en tejido de poliéster Trevira CS®.

Halterung aus verchromtem Metall für die Wand- oder Deckenmontage mit 5 neigbaren Akustikpaneelen, innen mit Polyester in **unterschiedlicher Dichte** unter Verwendung der Snowsound®-Technologie gepolstert. Oberfläche aus Polyesterstoff Trevira CS®.

Verde chiaro
Light green
Vert clair
7004

7LW5/CL-7004

Grigio scuro
Dark grey
Gris foncé
8007

7LW5/CL-8007

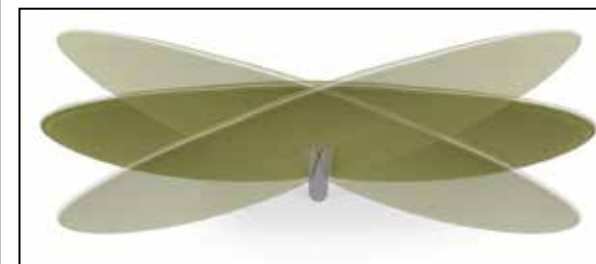

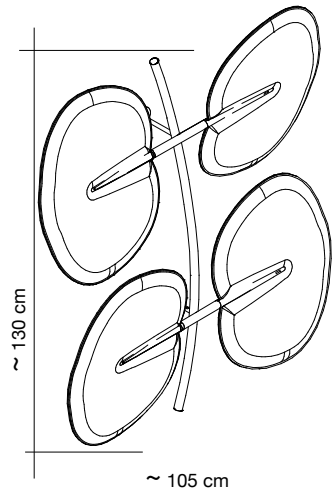

Colore
Colour

Bianco
White
Blanc
0012

Verde chiaro
Light green
Vert clair
7004

Grigio scuro
Dark grey
Gris foncé
8007

Codice/Code
Prezzo/Price

7LW4/CL-0012

Struttura in metallo cromato per fissaggio a parete o a soffitto completa di 4 pannelli orientabili con imbottitura interna in poliester a **densità variabile** Snowsound® Technology. Rivestimento esterno in tessuto di poliester Trevira CS®.

Structure in chrome-plated metal for wall or ceiling fixing with 4 adjustable panels composed of **variable density** polyester internal padding Snowsound® Technology. External polyester covering in Trevira CS® fabric.

7LW4/CL-7004

Structure en metal chromé pour montage mural ou à plafond avec 4 panneaux orientables avec rembourrage interne en polyester à **densité variable** Snowsound® Technology. Revêtement externe en tissu de polyester Trevira CS®.

7LW4/CL-8007

Estructura de metal cromado para montaje en pared o techo con 4 paneles orientables con acolchado interior de poliéster de **densidad variable** Snowsound® Technology. Revestimiento exterior en tejido de poliéster Trevira CS®.

Halterung aus verchromtem Metall für die Wand- oder Deckenmontage mit 4 neigbaren Akustikpaneelen, innen mit Polyester in **unterschiedlicher Dichte** unter Verwendung der Snowsound®-Technologie gepolstert. Oberfläche aus Polyesterstoff Trevira CS®.

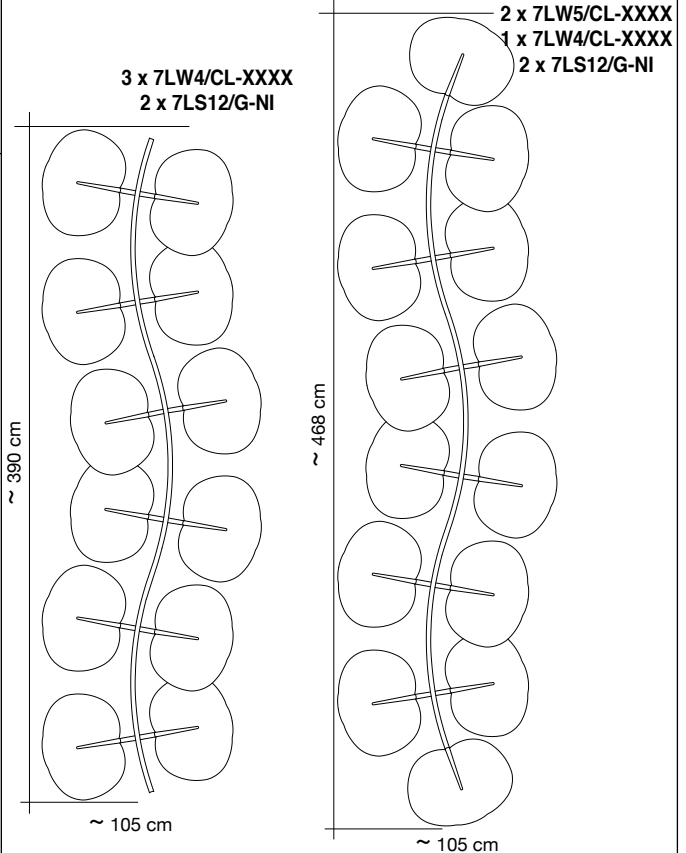
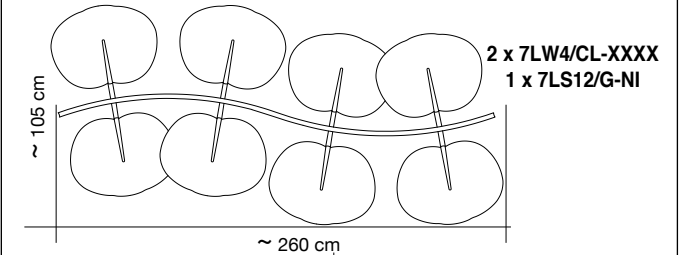
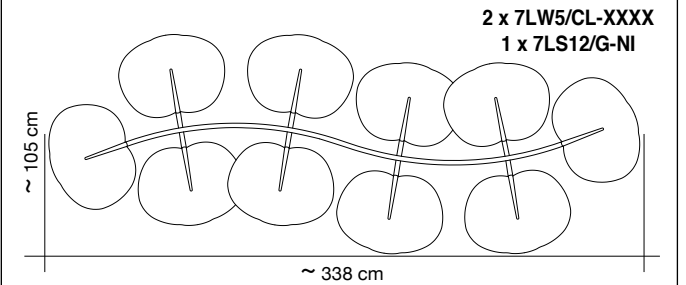

7LS12/G-NI

Giunto di collegamento strutture in metallo cromato. Per art. 7LW5/CL-XXXX e 7LW4/CL-XXXX (XXXX = variante colore)

Chrome-plated metal connecting joint for structures. For articles 7LW5/CL-XXXX and 7LW4/CL-XXXX (XXXX = Color option).

Joint de raccordement pour structures en metal chromé. Pour les articles 7LW5/CL-XXXX et 7LW4/CL-XXXX (XXXX = option couleur).

Junta de unión para estructuras de metal cromado. Para cod. 7LW5/CL-XXXX e 7LW4/CL-XXXX (XXXX = Variante color).

Verbindungsstück für verchromte Metallkonstruktionen. Für Art. 7LW5/CL-XXXX e 7LW4/CL-XXXX (XXXX = Farbvariante).

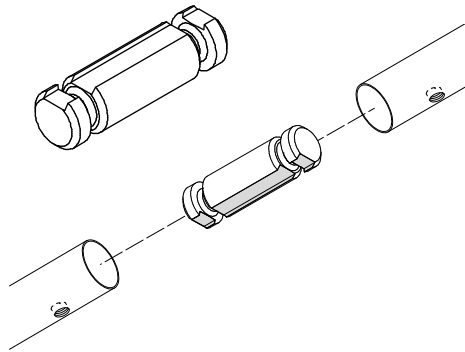

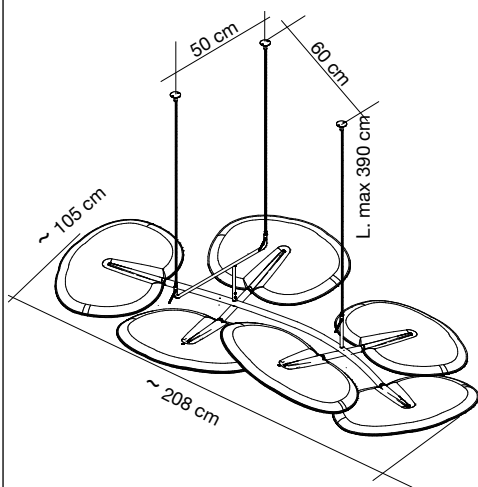

Colore
Colour

Bianco
White
Blanc
0012

Codice/Code
Prezzo/Price

7LC6/CL-0012

Struttura in metallo cromato per fissaggio a soffitto completa di 6 pannelli orientabili con imbottitura interna in poliester a **densità variabile** Snowsound® Technology. Rivestimento esterno in tessuto di poliester Trevira CS®.

Structure in chrome-plated metal for ceilingl fixing with 6 adjustable panels composed of **variable density** polyester internal padding Snowsound® Technology. External polyester covering in Trevira CS® fabric.

Structure en metal chromé pour montage au plafond avec 6 panneaux orientables avec rembourrage interne en polyester à **densité variable** Snowsound® Technology. Revêtement externe en tissu de polyester Trevira CS®.

Estructura de metal cromado para montaje en techo con 6 paneles orientables con acolchado interior de poliéster de **densidad variable** Snowsound® Technology. Revestimiento exterior en tejido de poliéster Trevira CS®

Halterung aus verchromtem Metall für die Deckenmontage mit 6 neigbaren Akustikpaneelen, innen mit Polyester in **unterschiedlicher Dichte** unter Verwendung der Snowsound®-Technologie gepolstert. Oberfläche aus Polyesterstoff Trevira CS®.

Verde chiaro
Light green
Vert clair
7004

7LC6/CL-7004

Grigio scuro
Dark grey
Gris foncé
8007

7LC6/CL-8007

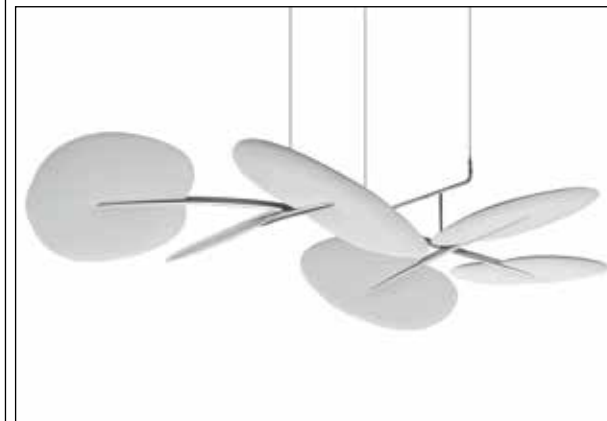

Kit per fissaggio a soffitto composto da: 3 piastre a soffitto a 2 fori - 3 cavi in acciaio - 3 attacchi a telaio

Kit for the ceiling fixing composed of: 3 ceiling plates with 2 holes - 3 steel cables - 3 hangings

Kit d'accrochage au plafond composé de: 3 platines pour plafond à 2 trous - 3 câbles en acier - 3 accrochages

Kit para el montaje al techo compuesto por: 3 placas de techo con 2 huecos - 3 cables de acero, 3 enganches

Set für die Deckenbefestigung bestehend aus: 3 Deckenmontageplatten mit 2 Befestigungsbohrungen, 3 Stahlseile, 3 Befestigungen

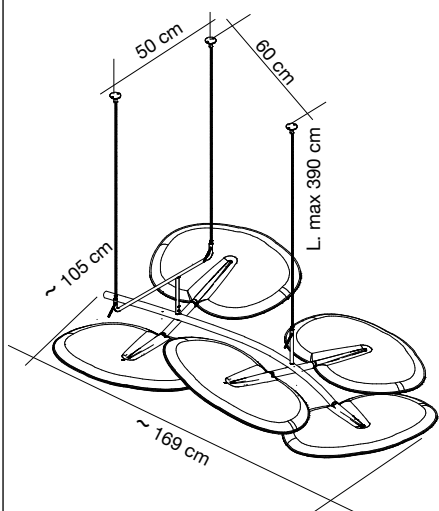

Colore
Colour

Bianco
White
Blanc
0012

Codice/Code
Prezzo/Price

7LC5/CL-0012

Struttura in metallo cromato per fissaggio a soffitto completa di 5 pannelli orientabili con imbottitura interna in poliester a **densità variabile** Snowsound® Technology. Rivestimento esterno in tessuto di poliester Trevira CS®.

Structure in chrome-plated metal for ceilingl fixing with 5 adjustable panels composed of **variable density** polyester internal padding Snowsound® Technology. External polyester covering in Trevira CS® fabric.

Structure en metal chromé pour montage au plafond avec 5 panneaux orientables avec rembourrage interne en polyester à **densité variable** Snowsound® Technology. Revêtement externe en tissu de polyester Trevira CS®.

Estructura de metal cromado para montaje en techo con 5 paneles orientables con acolchado interior de poliéster de **densidad variable** Snowsound® Technology. Revestimiento exterior en tejido de poliéster Trevira CS®

Halterung aus verchromtem Metall für die Deckenmontage mit 5 neigbaren Akustikpaneelen, innen mit Polyester in **unterschiedlicher Dichte** unter Verwendung der Snowsound®-Technologie gepolstert. Oberfläche aus Polyesterstoff Trevira CS®.

Verde chiaro
Light green
Vert clair
7004

7LC5/CL-7004

Grigio scuro
Dark grey
Gris foncé
8007

7LC5/CL-8007

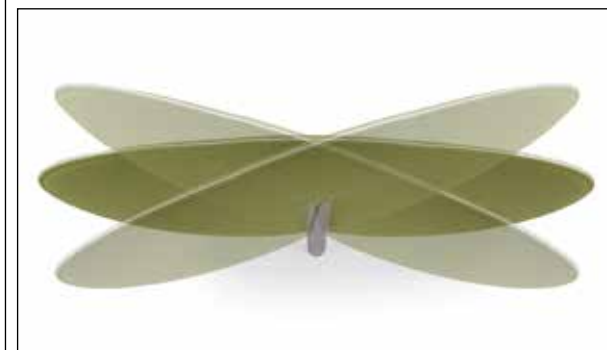

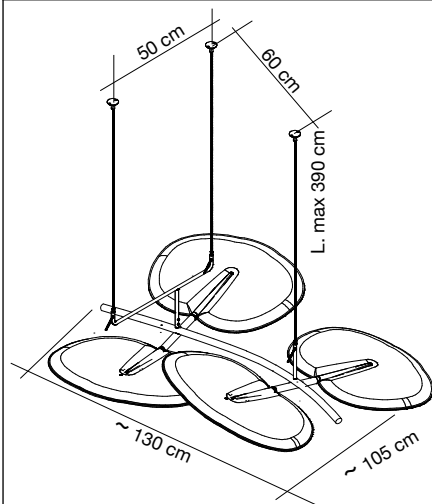

Colore
Colour

Bianco
White
Blanc
0012

Verde chiaro
Light green
Vert clair
7004

Grigio scuro
Dark grey
Gris foncé
8007

Codice/Code
Prezzo/Price

7LC4/CL-0012

Struttura in metallo cromato per fissaggio a soffitto completa di 4 pannelli orientabili con imbottitura interna in poliester a **densità variabile** Snowsound® Technology. Rivestimento esterno in tessuto di poliester Trevira CS®.

7LC4/CL-7004

Structure en metal chromé pour montage au plafond avec 4 panneaux orientables avec rembourrage interne en polyester à **densité variable** Snowsound® Technology. Revêtement externe en tissu de polyester Trevira CS®.

7LC4/CL-8007

Estructura de metal cromado para montaje en techo con 4 paneles orientables con acolchado interior de poliester de **densidad variable** Snowsound® Technology. Revestimiento exterior en tejido de poliester Trevira CS®.

Halterung aus verchromtem Metall für die Deckenmontage mit 4 neigbaren Akustikpaneelen, innen mit Polyester in **unterschiedlicher Dichte** unter Verwendung der Snowsound®-Technologie gepolstert. Oberfläche aus Polyesterstoff Trevira CS®.

7LS12/G-NI

Giunto di collegamento strutture in metallo cromato. Per art. 7LW5/CL-XXXX e 7LW4/CL-XXXX (XXXX = variante colore)

Chrome-plated metal connecting joint for structures. For articles 7LW5/CL-XXXX e 7LW4/CL-XXXX (XXXX = Color option).

Joint de raccordement pour structures en metal chromé. Pour les articles 7LW5/CL-XXXX e 7LW4/CL-XXXX (XXXX = option couleur).

Junta de unión para estructuras de metal cromado. Para cod. 7LW5/CL-XXXX e 7LW4/CL-XXXX (XXXX = Variante color).

Verbindungsstück für verchromte Metallkonstruktionen. Für Art. 7LW5/CL-XXXX e 7LW4/CL-XXXX (XXXX = Farbvariante).

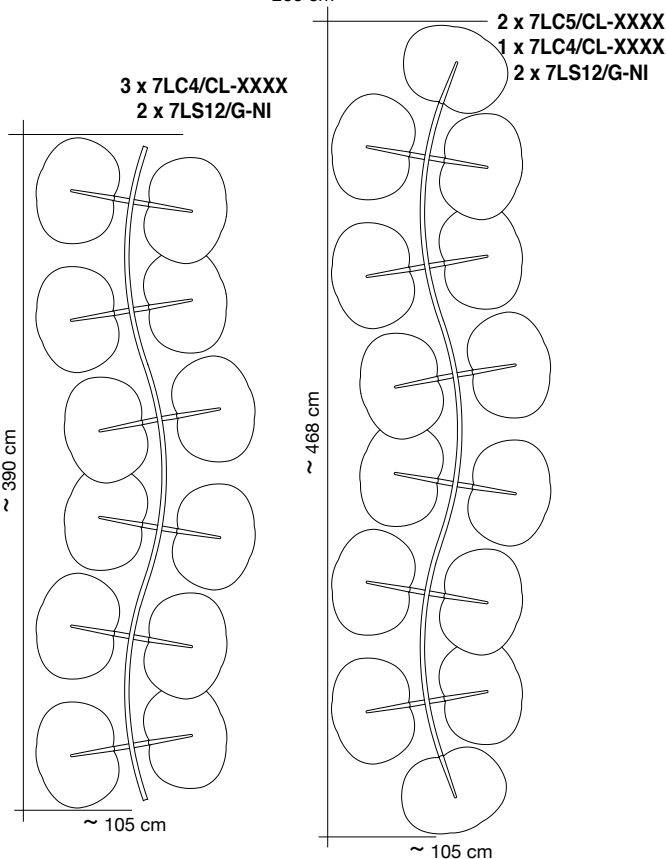
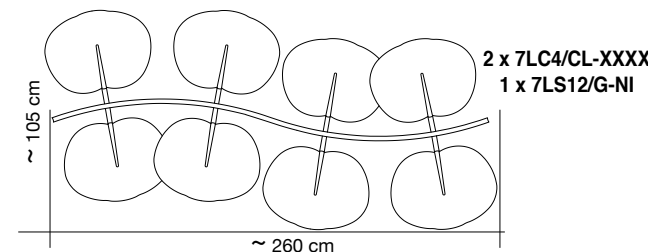
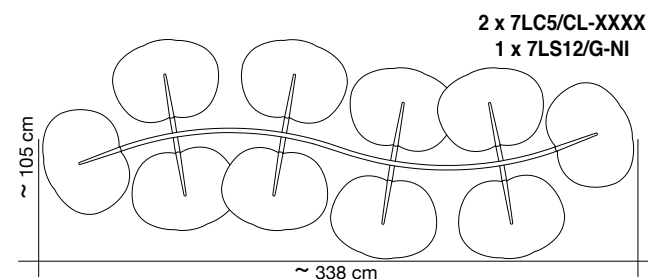
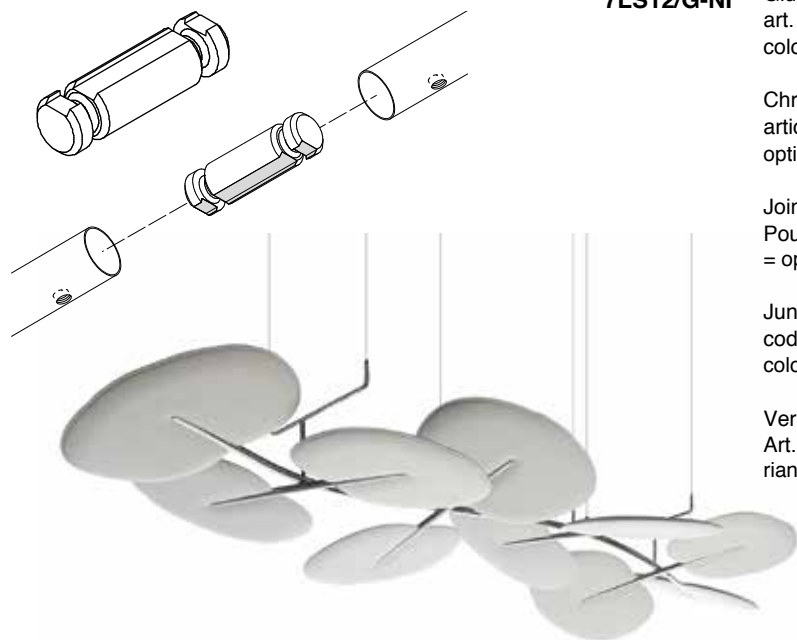

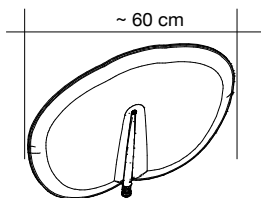

Colore
Colour

Codice/Code
Prezzo/Price

Bianco
White
Blanc
0012

7LP60S1/CL-0012

Verde chiaro
Light green
Vert clair
7004

7LP60S1/CL-7004

Grigio scuro
Dark grey
Gris foncé
8007

7LP60S1/CL-8007

Pannello orientabile con imbottitura interna in poliester a **densità variabile** Snowsound® Technology. Rivestimento esterno in tessuto di poliester Trevira CS®.
Completo di attacco in metallo cromato per fissaggio a strutture Botanica Totem cod. 7LT6S-CLBO

Adjustable panel with **variable density** polyester internal padding Snowsound® Technology. External polyester covering in Trevira CS® fabric.
Equipped with chrome-plated metal plate for fixing to Botanica Totem code 7LT6S-CLBO

Panneau orientable avec rembourrage interne en polyester à **densité variable** Snowsound® Technology. Revêtement externe en tissu de polyester Trevira CS®.
Fourni avec connexion métallique chromée pour montage à la structure Botanica Totem art. 7LT6S-CLBO

Panel orientable con acolchado interior de poliéster de **densidad variable** Snowsound® Technology. Revestimiento exterior en tejido de poliéster Trevira CS®.
Se completa con placa metálica cromada para montaje a la estructura Botanica Totem cod. 7LT6S-CLBO

Neigbares Akustikpaneel, innen mit Polyester in **unterschiedlicher Dichte** unter Verwendung der Snowsound®-Technologie gepolstert. Oberfläche aus Polyesterstoff Trevira CS®.
Inklusive Halterung aus verchromtem Metall für Botanica Totem Art 7LT6S-CLBO.

7LT6S-CLBO

Bianco opaco /
Cromato
Mat white /
Chrome-plated
Blanc mat /
Chromé
Blanco mate /
Cromado
Matweiß /
Verchromtem

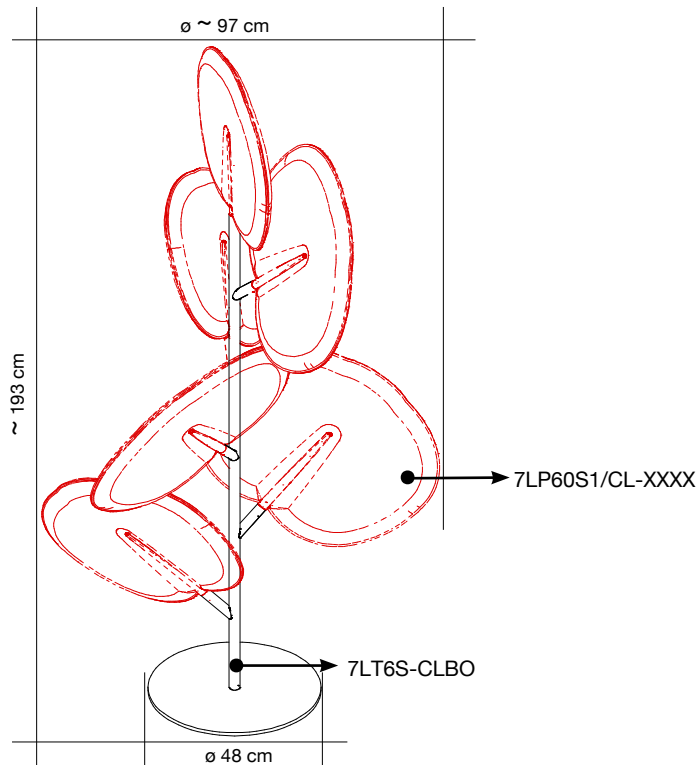
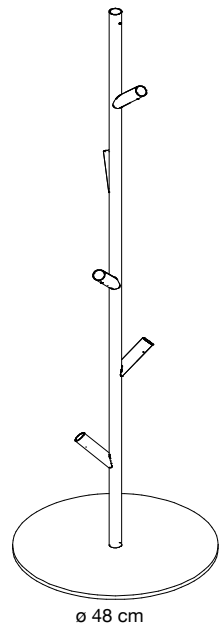

Struttura in metallo cromato con base in acciaio verniciato con polveri epossidiche per il montaggio di 6 pannelli Botanica 7LP60S1/CL-XXXX (XXXX = Variante colore).

Structure in chrome-plated metal with powder-coated steel base to mount 6 Botanica panels code 7LP60S1/CL-XXXX (XXXX = Color option).

Structure en metal chromé avec base en acier peint époxy pour l'accrochage de 6 panneaux Botanica 7LP60S1/CL-XXXX (XXXX = option couleur)

Estructura de metal cromado con base de acero recubierto epoxi para el montaje de 6 paneles Botanica 7LP60S1/CL-XXXX (XXXX = Variante color).

Standsäule aus verchromtem Metall mit Standfuß aus pulverbeschichtetem Stahl, für 6 Botanica-Paneele Art. 7LP60S1/CL-XXXX (XXXX = Farbvariante).



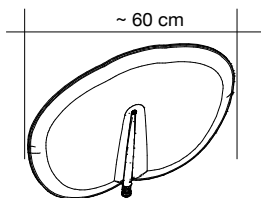

Colore
Colour

Bianco
White
Blanc
0012

Codice/Code
Prezzo/Price

7LP60S1/CL-0012

Pannello orientabile con imbottitura interna in poliester a **densità variabile** Snowsound® Technology. Rivestimento esterno in tessuto di poliester Trevira CS®. Completo di attacco in metallo cromato per fissaggio a strutture Botanica Wall cod. 7LS12C-CL e Botanica Celing. cod. 7LS12W-CL

Adjustable panel with **variable density** polyester internal padding Snowsound® Technology. External polyester covering in Trevira CS® fabric. Equipped with chrome-plated metal plate for fixing Botanica Wall code 7LS12C-CL and Botanica Celing. code 7LS12W-CL

Verde chiaro
Light green
Vert clair
7004

7LP60S1/CL-7004

Panneau orientable avec rembourrage interne en polyester à **densité variable** Snowsound® Technology. Revêtement externe en tissu de polyester Trevira CS®. Fourni avec connexion métallique chromée pour montage à las structures Botanica Wall art. 7LS12C-CL et Botanica Celing. art. 7LS12W-CL

Grigio scuro
Dark grey
Gris foncé
8007

7LP60S1/CL-8007

Panel orientable con acolchado interior de poliéster de **densidad variable** Snowsound® Technology. Revestimiento exterior en tejido de poliéster Trevira CS®. PSe completa con placa metálica cromada para montaje a la estructuras Botanica Wall cod. 7LS12C-CL y Botanica Celing. cod. 7LS12W-CL

Neigbares Akustikpaneel, innen mit Polyester in **unterschiedlicher Dichte** unter Verwendung der Snowsound®-Technologie gepolstert. Oberfläche aus Polyesterstoff Trevira CS®. Inklusive Halterung aus verchromtem Metall für Strukturen Botanica Wall Art7LS12C-CL und Botanica Celing. Art 7LS12W-CL.

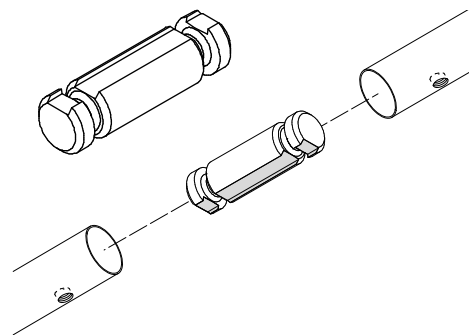

7LS12/G-NI

Giunto di collegamento strutture in metallo cromato. Per art. 7LS12W-CL e 7LS12C-CL.

Chrome-plated metal connecting joint for structures. For articles 7LS12W-CL and 7LS12C-CL.

Joint de raccordement pour structures en metal chromé. Pour les articles 7LS12W-CL et 7LS12C-CL.

Junta de unión para estructuras de metal cromado. Para cod. 7LS12W-CL y 7LS12C-CL.

Verbindungsstück für verchromte Metalkonstruktionen. Für Art. 7LS12W-CL und 7LS12C-CL.

Codice/Code
Prezzo/Price

7LS12W-CL

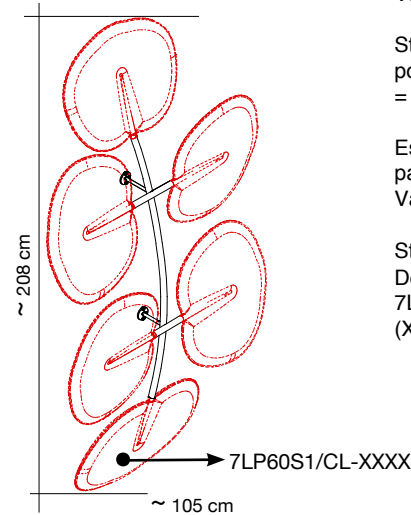
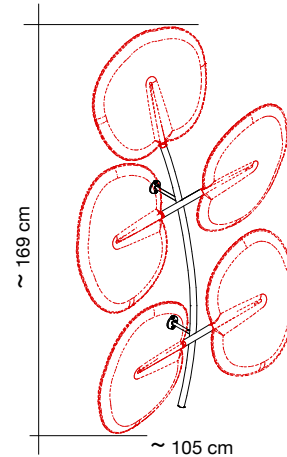
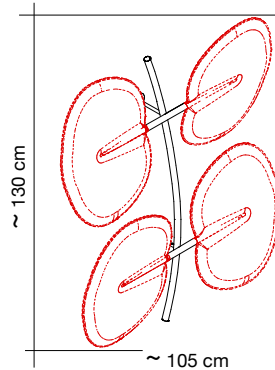
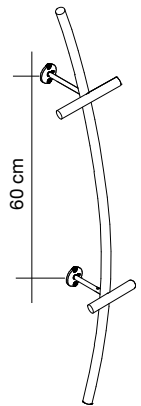

Struttura in metallo cromato per fissaggio a parete o a soffitto di 4, 5 o 6 pannelli Botanica 7LP60S1/CL-XXXX (XXXX = Variante colore).

Structure in chrome-plated metal for wall or ceiling fixing for 4, 5 or 6 Botanica panels code 7LP60S1/CL-XXXX (XXXX = Variante colore).

Structure en metal chromé pour montage mural ou à plafond pour 4, 5 ou 6 panneaux Botanica 7LP60S1/CL-XXXX (XXXX = Variante colore).

Estructura de metal cromado para montaje en pared o techo para 4, 5 o 6 paneles Botanica 7LP60S1/CL-XXXX (XXXX = Variante colore).

Standssäule aus verchromtem Metall für die Wand- oder Deckenmontage für 4, 5 oder 6 Akustikpaneel, Botanica Art. 7LP60S1/CL-XXXX (XXXX = Variante colore).

7LS12C-CL

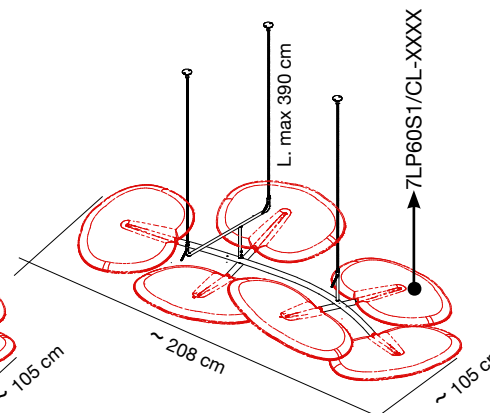
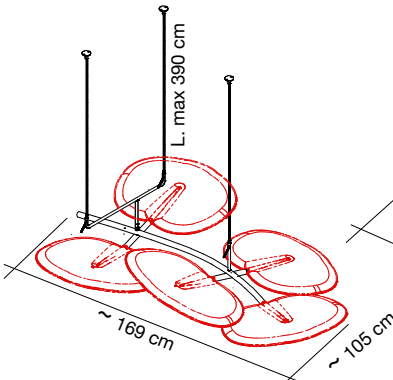
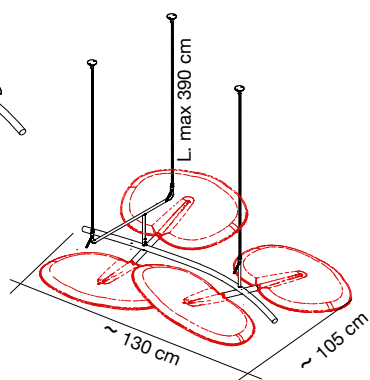
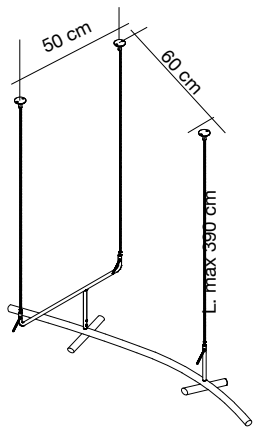

Struttura in metallo cromato per fissaggio a soffitto di 4, 5 o 6 pannelli Botanica 7LP60S1/CL-XXXX (XXXX = Variante colore). Kit per fissaggio a soffitto composto da: 3 piastre a soffitto a 2 fori - 3 cavi in acciaio - 3 attacchi a telaio

Structure in chrome-plated metal for ceiling fixing for 4, 5 or 6 Botanica panels code 7LP60S1/CL-XXXX (XXXX = Variante colore). Kit for the ceiling fixing composed of: 3 ceiling plates with 2 holes - 3 steel cables - 3 hangings

Structure en metal chromé pour montage au plafond pour 4, 5 ou 6 panneaux Botanica 7LP60S1/CL-XXXX (XXXX = Variante colore). Kit d'accrochage au plafond composé de: 3 platines pour plafond à 2 trous - 3 câbles en acier - 3 accrochages

Estructura de metal cromado para montaje en techo para 4, 5 o 6 paneles Botanica 7LP60S1/CL-XXXX (XXXX = Variante colore). Kit para el montaje al techo compuesto por: 3 placas de techo con 2 huecos - 3 cables de acero, 3 enganches

Standssäule aus verchromtem Metall für die Deckenmontage für 4, 5 oder 6 Akustikpaneel, Botanica Art. 7LP60S1/CL-XXXX (XXXX = Variante colore). Set für die Deckenbefestigung bestehend aus: 3 Deckenmontageplatten mit 2 Befestigungsbohrungen, 3 Stahlseile, 3 Befestigungen

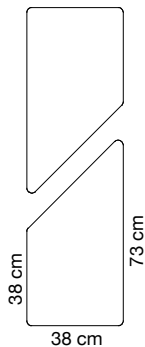
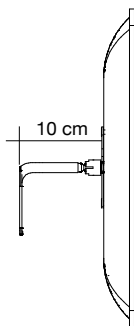

Colore
Colour

Bianco
White
Blanc
0012

Codice/Code
Prezzo/Price

7FF3807/2-0012

1 coppia /1 pair
1 paire / 1 pare
1 Paar

Coppia di pannelli con imbottitura interna in poliester a **densità variabile** Snowsound® Technology. Rivestimento esterno in tessuto di poliester Trevira CS®. Completo di braccio in acciaio cromato per fissaggio a parete o soffitto (viti non incluse). Il pannello è inclinabile in tutte le direzioni e può ruotare di 360°.

Pair of panels with **variable density** polyester internal padding Snowsound® Technology. External polyester covering in Trevira CS® fabric. Equipped with chrome-plated steel bracket for wall or ceiling fixing (screws not included). The panel can be tilted in any direction and can rotate 360 degrees.

Paire de panneaux avec rembourrage interne en polyester à **densité variable** Snowsound® Technology. Revêtement externe en tissu de polyester Trevira CS®. Fourni avec bras en acier chromé pour fixation au mur ou à plafond (vis non incluses) Le panneau peut être incliné dans toutes les directions et pivoter sur 360°.

Par de paneles con acolchado interior de poliéster de **densidad variable** Snowsound® Technology. Revestimiento exterior en tejido de poliéster Trevira CS®. Se completa con brazo de acero cromado para fijación a pared o techo (tornillos no incluidos). El panel tiene inclinación en todas direcciones y puede rotar a 360°.

1 Paar Paneele mit Polyester-Füllmaterial von **unterschiedlicher Dichte** (Snowsound® Technologie). Polyester-Bezug aus Trevira CS®-Material. Ausgestattet mit einem Montagewinkel mit Kugelgelenk zur Befestigung an der Wand oder Decke (Schrauben nicht inkludiert). Das Paneel kann in jede Richtung geneigt und um 360 Grad gedreht werden.

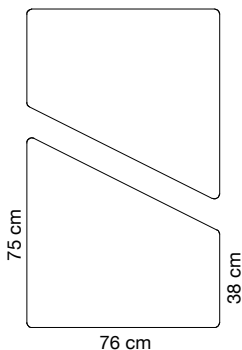
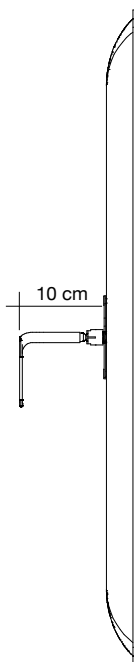

Colore
Colour

Bianco
White
Blanc
0012

Codice/Code
Prezzo/Price

7FF7607/2-0012

1 coppia /1 pair
1 paire / 1 pare
1 Paar



Colore
Colour

Codice/Code
Prezzo/Price

Bianco
White
Blanc
0012

7FFD12/CL-0012

Struttura in acciaio cromato con base in acciaio verniciato con polveri epossidiche completa di 12 pannelli Flat.

Chrome-plated steel structure with epoxy powder-coated steel base, complete with 12 Flat panels.

Structure en acier chromé avec base en acier peint epoxy avec poudres époxy et 12 panneaux Flat.

Estructura de acero cromado con base de acero pintado con polvos epoxídicos y 12 paneles Flat.

Struktur bestehend aus 2 Standsäulen aus verchromtem Stahl mit Bodenplatte aus pulverbeschichtetem Stahl, inklusive 12 Flat Paneelen.

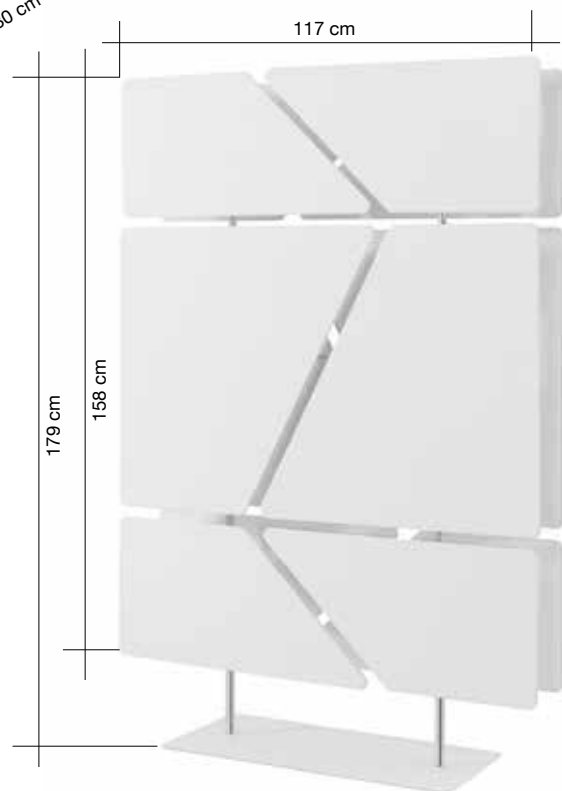
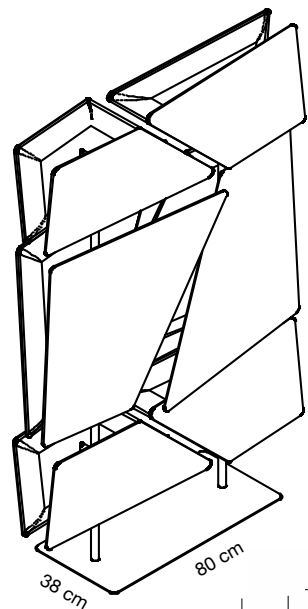

FLAP

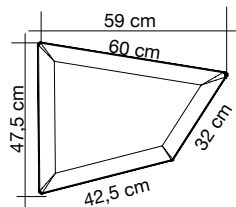
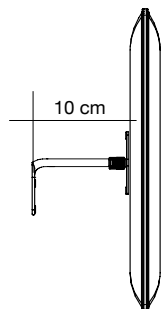

FLAP

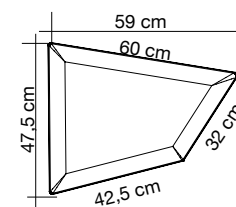
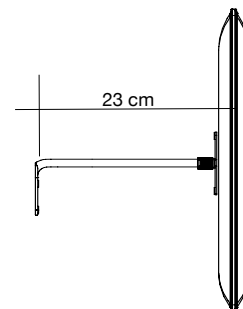

Colore Colour	Codice/Code Prezzo/Price	Colore Colour	Codice/Code Prezzo/Price	Colore Colour	Codice/Code Prezzo/Price	Colore Colour	Codice/Code Prezzo/Price
Bianco White Blanc 0001	7F1007-0001	Arancione Orange Orange 4030	7F1007-4030	Bianco White Blanc 0001	7F1020-0001	Arancione Orange Orange 4030	7F1020-4030
Grigio argento Silver grey Gris argenté 8004	7F1007-8004	Rosso Red Rouge 4027	7F1007-4027	Grigio argento Silver grey Gris argenté 8004	7F1020-8004	Rosso Red Rouge 4027	7F1020-4027
Grigio scuro Dark grey Gris foncé 8007	7F1007-8007	Verde chiaro Light green Vert clair 7004	7F1007-7004	Grigio scuro Dark grey Gris foncé 8007	7F1020-8007	Verde chiaro Light green Vert clair 7004	7F1020-7004
Beige Beige Beige 1008	7F1007-1008	Verde Green Vert 7013	7F1007-7013	Beige Beige Beige 1008	7F1020-1008	Verde Green Vert 7013	7F1020-7013
Tortora Dove-grey Taupe 2005	7F1007-2005	Blu Blue Bleu 6071	7F1007-6071	Tortora Dove-grey Taupe 2005	7F1020-2005	Blu Blue Bleu 6071	7F1020-6071
Giallo Yellow Jaune 3008	7F1007-3008	Nero Black Noir 8033	7F1007-8033	Giallo Yellow Jaune 3008	7F1020-3008	Nero Black Noir 8033	7F1020-8033

MAXIFLAP

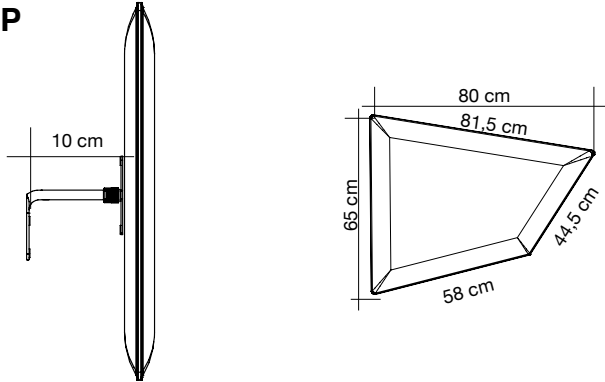

MAXIFLAP

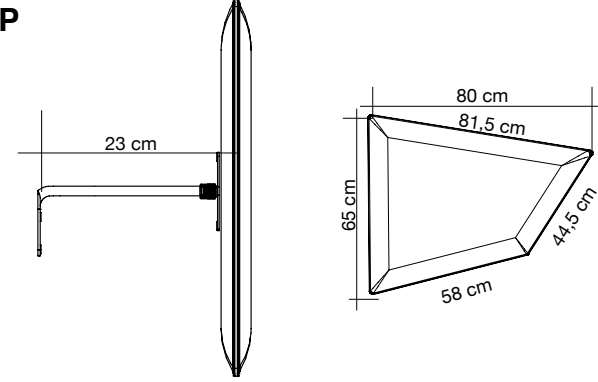

Colore Colour	Codice/Code Prezzo/Price	Colore Colour	Codice/Code Prezzo/Price	Colore Colour	Codice/Code Prezzo/Price	Colore Colour	Codice/Code Prezzo/Price
Bianco White Blanc 0001	7F2007-0001	Arancione Orange Orange 4030	7F2007-4030	Bianco White Blanc 0001	7F2020-0001	Arancione Orange Orange 4030	7F2020-4030
Grigio argento Silver grey Gris argenté 8004	7F2007-8004	Rosso Red Rouge 4027	7F2007-4027	Grigio argento Silver grey Gris argenté 8004	7F2020-8004	Rosso Red Rouge 4027	7F2020-4027
Grigio scuro Dark grey Gris foncé 8007	7F2007-8007	Verde chiaro Light green Vert clair 7004	7F2007-7004	Grigio scuro Dark grey Gris foncé 8007	7F2020-8007	Verde chiaro Light green Vert clair 7004	7F2020-7004
Beige Beige Beige 1008	7F2007-1008	Verde Green Vert 7013	7F2007-7013	Beige Beige Beige 1008	7F2020-1008	Verde Green Vert 7013	7F2020-7013
Tortora Dove-grey Taupe 2005	7F2007-2005	Blu Blue Bleu 6071	7F2007-6071	Tortora Dove-grey Taupe 2005	7F2020-2005	Blu Blue Bleu 6071	7F2020-6071
Giallo Yellow Jaune 3008	7F2007-3008	Nero Black Noir 8033	7F2007-8033	Giallo Yellow Jaune 3008	7F2020-3008	Nero Black Noir 8033	7F2020-8033

Alcuni esempi di possibili composizioni con pannelli Flap/Maxiflap cod. 7F1007-XXXX / 7F1020-XXXX / 7F2007-XXXX e 7F2020-XXXX (XXXX = Variante colore) e relativi ingombri indicativi.

Some examples of possible compositions with panels Flap/Maxiflap cod. 7F1007-XXXX / 7F1020-XXXX / 7F2007-XXXX and 7F2020-XXXX (XXXX = Color option) and related indicative dimensions.

Quelques exemples de compositions possibles avec les panneaux Flap/Maxiflap code 7F1007-XXXX / 7F1020-XXXX / 7F2007-XXXX et 7F2020-XXXX (XXXX = option couleur) et dimensions indicatives.

Algunos ejemplos de posibles composiciones con paneles Flap/Maxiflap cod. 7F1007-XXXX / 7F1020-XXXX / 7F2007-XXXX y 7F2020-XXXX (XXXX = Variante color) y dimensiones indicativas correspondientes.

Einige Beispiele von möglichen Zusammenstellungen der Flap/Maxiflap-Paneele Art.Nr. 7F1007-XXXX / 7F1020-XXXX / 7F2007-XXXX und 7F2020-XXXX (XXXX = Farbvariante) mit den jeweiligen ungefähren Abmessungen.

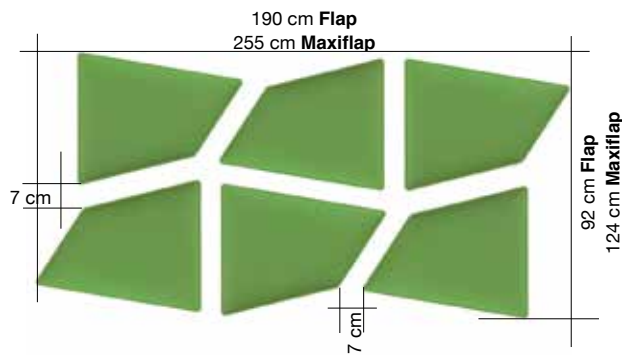
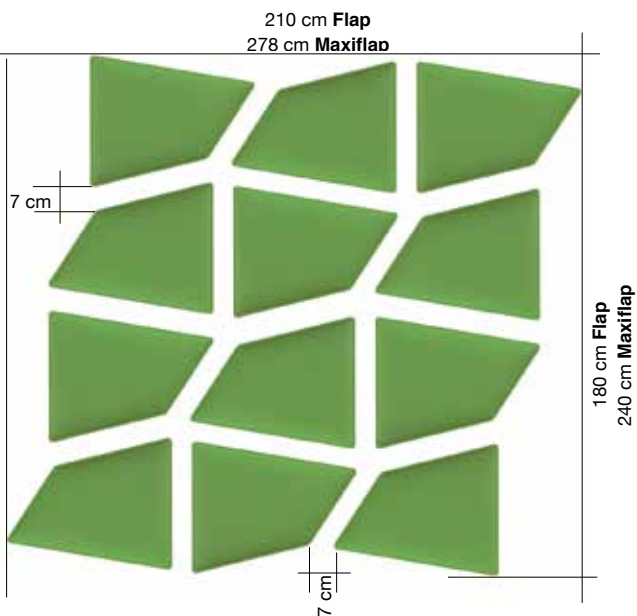
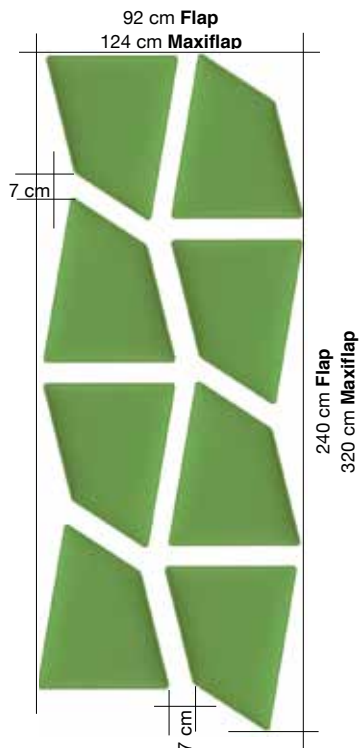
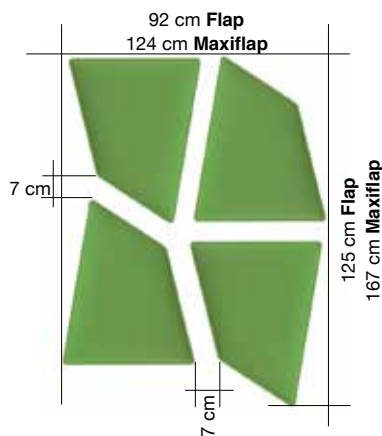

design **Alberto Meda, Francesco Meda**
Snowsound® technology by **Caimi Brevetti**

Descrizione

Description

Pannello con imbottitura interna in poliestere a **densità variabile** Snowsound® Technology. Rivestimento esterno in tessuto di poliestere Trevira CS®. Completo di braccio in acciaio cromato per fissaggio a parete o a soffitto (viti non incluse). Il pannello è inclinabile in tutte le direzioni e può ruotare di 360°.

Panel with polyester internal padding with Snowsound® Technology **variable density**. Polyester covering in Trevira CS® fabric. Equipped with chrome-plated steel bracket for wall or ceiling fixing (screws not included). The panel can be tilted in any direction and can rotate 360 degrees.

Panneau avec rembourrage interne en polyester à **densité variable** Snowsound® Technology. Revêtement externe en tissu de polyester Trevira CS®. Fourni avec bras en acier chromé pour fixation au mur ou au plafond (vis pas inclus). Le panneau peut être incliné dans toutes les directions et pivoter sur 360°.

Panel con acolchado interior de poliéster de **densidad variable** Snowsound® Technology. Revestimiento exterior en tejido de poliéster Trevira CS®. Completo con brazo de acero cromado para fijación a pared o al techo (tornillos no incluidos). El panel es inclinable en todas direcciones y puede rotar a 360°.

Panel mit Polyester-Füllmaterial von **unterschiedlicher Dichte** Snowsound® Technology. Polyester-Bezug aus Trevira CS®-Material. Ausgestattet mit einem Montagewinkel mit Kugelgelenk zur Befestigung an Wand oder Decke (Schrauben nicht inkludiert). Das Paneel kann in jede Richtung geneigt und um 360 Grad gedreht werden.

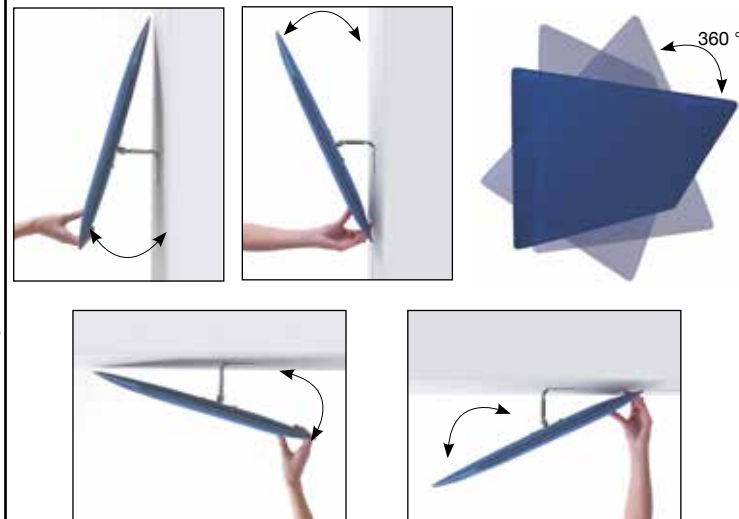

Esempio utilizzo dime fornite con i pannelli Flap/Maxiflap cod. 7F1007-XXXX / 7F1020-XXXX / 7F2007-XXXX e 7F2020-XXXX (XXXX = Variante colore).

Example for the use of templates provided with Flap/Maxiflap panels cod. 7F1007-XXXX / 7F1020-XXXX / 7F2007-XXXX and 7F2020-XXXX (XXXX = Color option).

Exemples d'utilisation modèles fournis avec les panneaux Flap/Maxiflap code 7F1007-XXXX / 7F1020-XXXX / 7F2007-XXXX et 7F2020-XXXX (XXXX = option couleur).

Ejemplo de uso de las plantillas suministradas con los paneles Flap/Maxiflap cod. 7F1007-XXXX / 7F1020-XXXX / 7F2007-XXXX y 7F2020-XXXX (XXXX = Variante color).

Beispiel für die Verwendung der mit den Flap/Maxiflap Paneelen Art.Nr. 7F1007-XXXX / 7F1020-XXXX / 7F2007-XXXX und 7F2020-XXXX (XXXX = Farbvariante) mitgelieferten Papierschablone.

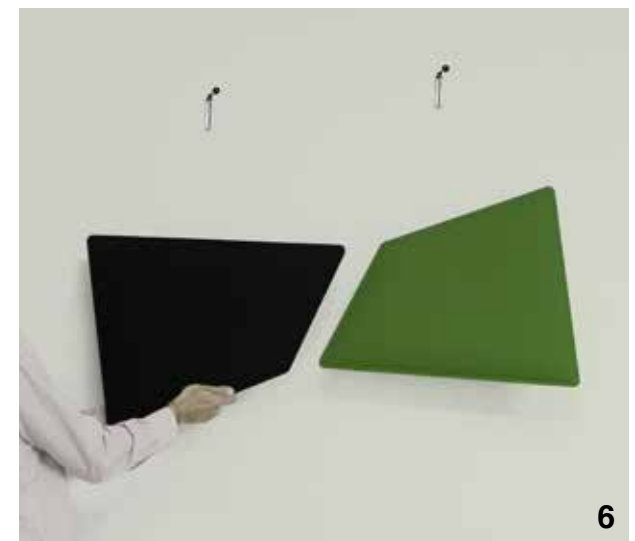
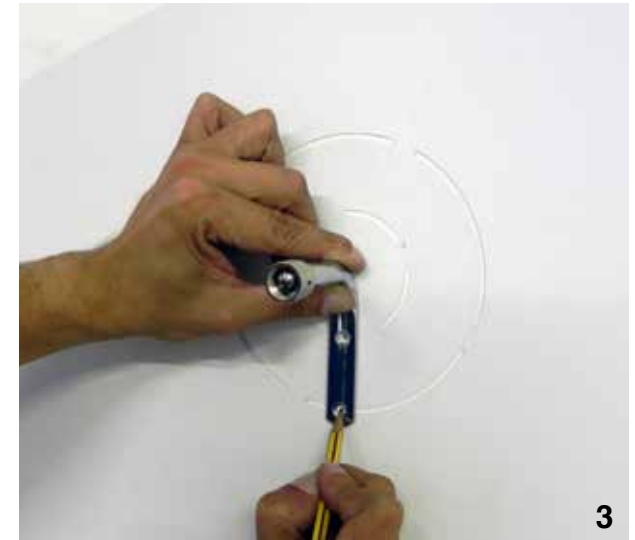
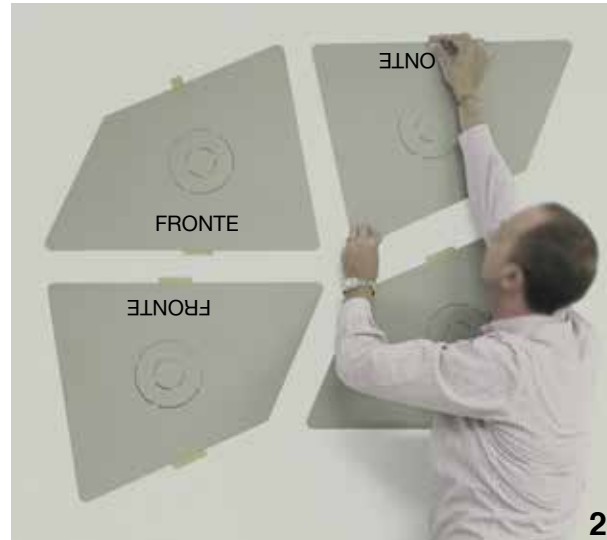

7FL110

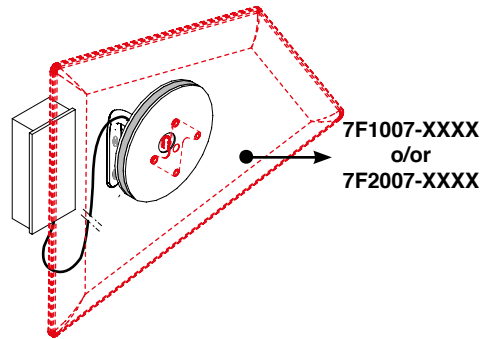
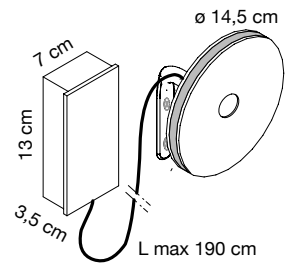

Led (6 W - 3200° K) per pannelli Flap (cod. 7F1007-XXXX) e Maxiflap (cod. 7F2007-XXXX) completo di alimentatore.

Led (6 W - 3200° K) for Flap (cod. 7F1007-XXXX) and Maxiflap (cod. 7F2007-XXXX) panels, complete with power supply.

Led (6 W - 3200° K) pour panneaux Flap (réf. 7F1007-XXXX) et Maxiflap (réf. 7F2007-XXXX) avec alimentation.

Led (6 W - 3200° K) para paneles Flap (cod. 7F1007-XXXX) y Maxiflap (cod. 7F2007-XXXX) se completa con la fuente de alimentación.

LED-Beleuchtung (6 W - 3200° K) für die Paneele Flap (Art. Nr. 7F1007-XXXX) und Maxiflap (Art. Nr. 7F2007-XXXX), inklusive Stromzufuhr.

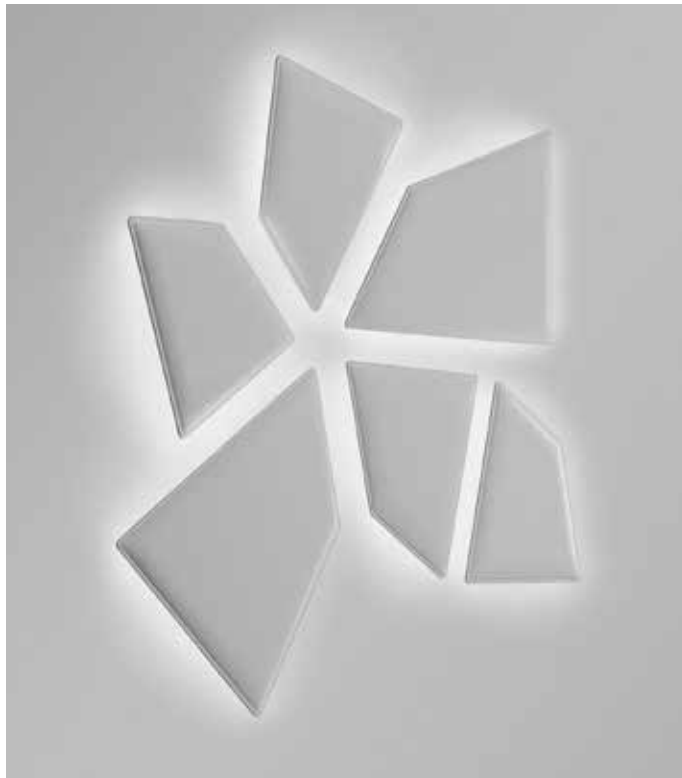

7FCL150

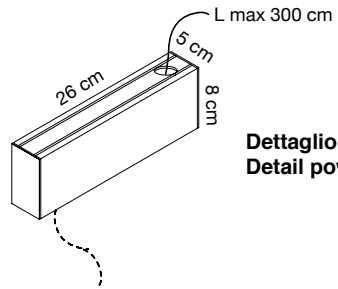
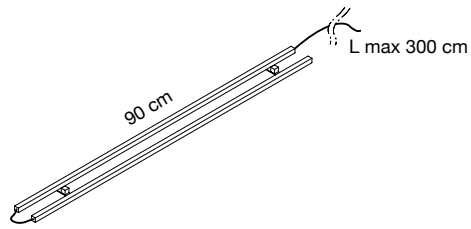

**Dettaglio alimentatore
Detail power supply**

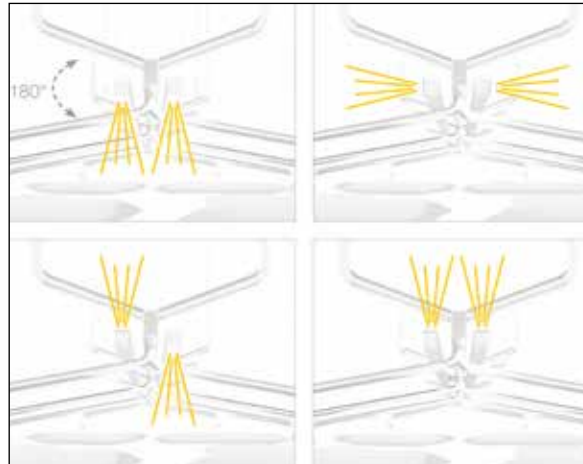
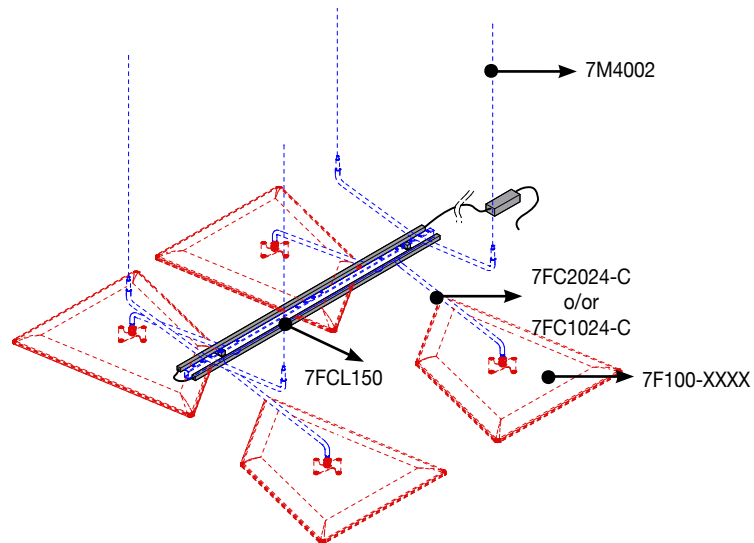

Coppia di profili con Led orientabili (2 x 25 W - 3000° K) per 1 telaio Flap cod. 7FC2024-C o 7FC1024-C + alimentatore (60 W) completo di carter di copertura in alluminio.

Pair of profiles with adjustable Led (2 x 25 W - 3000° K) for one Flap frame (product code 7FC2024-C or C-7FC1024) + Power supply (60 W) complete with aluminum cover

Paire de profils avec Led orientables (2 x 25 W - 3000° K) pour 1 structure Flap réf. 7FC2024-C ou 7FC1024-C + alimentateur (60 W) avec carter de couverture en aluminium.

Set de 2 perfiles con Led ajustables (2 x 25 W - 3000° K) para 1 estructurar Flap cod. 7FC2024-C o 7FC1024-C + unidad de alimentación (60 W) completa de carter de cobertura en aluminio.

Ein Paar Profile mit justierbaren LED (2 x 25 W - 3000° K) für eine Flap-Halterung zur Deckenmontage (Art. Nr. 7FC2024-C oder C-7FC1024) + Stromzufuhr (60 W) inklusive Abdeckung aus Aluminium.



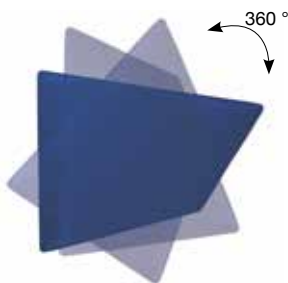
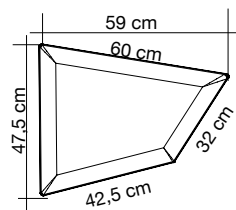
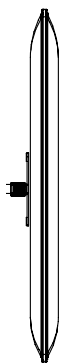

Colore Colour	Codice/Code Prezzo/Price	Colore Colour	Codice/Code Prezzo/Price
Bianco White Blanc 0001	7F100-0001	Arancione Orange Orange 4030	7F100-4030
Grigio argento Silver grey Gris argenté 8004	7F100-8004	Rosso Red Rouge 4027	7F100-4027
Grigio scuro Dark grey Gris foncé 8007	7F100-8007	Verde chiaro Light green Vert clair 7004	7F100-7004
Beige Beige Beige 1008	7F100-1008	Verde Green Vert 7013	7F100-7013
Tortora Dove-grey Taupe 2005	7F100-2005	Blu Blue Bleu 6071	7F100-6071
Giallo Yellow Jaune 3008	7F100-3008	Nero Black Noir 8033	7F100-8033

Descrizione Description

Pannello con imbottitura interna in poliester a **densità variabile** Snowsound® Technology. Rivestimento esterno in tessuto di poliester Trevira CS®. Completo di piastra e snodo in acciaio cromato per fissaggio ai telai a soffitto cod. 7FC1024-C e 7FC2024-C e ai totem cod. 7FT3006-BO e 7FT3006-N. Il pannello è inclinabile in tutte le direzioni e può ruotare di 360°.

Panel with polyester internal padding with Snowsound® Technology **variable density**. Polyester covering in Trevira CS® fabric. Equipped with plate and chrome-plated joint for fixing to frames hanging from the ceiling code 7FC1024-C and 7FC2024-C and to free-standing supports code 7FT3006-BO and 7FT3006-N. The panel can be tilted in any direction and can rotate 360 degrees.

Panneau avec rembourrage interne en polyester à **densité variable** Snowsound® Technology. Revêtement externe en tissu de polyester Trevira CS®. Fourni avec plaque et articulation en acier chromé pour la fixation des châssis au plafond code 7FC1024-C et 7FC2024-C, et aux totems code 7FT3006-BO et 7FT3006-N. Le panneau peut être incliné dans toutes les directions et pivoter sur 360°.

Panel con acolchado interior de poliéster de **densidad variable** Snowsound® Technology. Revestimiento exterior en tejido de poliéster Trevira CS®. Completo con placa y articulación de acero cromado para fijación al bastidor al techo 7FC1024-C et 7FC2024-C y a los totem FT3006-BO et 7FT3006-N. El panel es inclinable en todas direcciones y puede rotar a 360°

Akustikpaneel, innen mit Polyester in **unterschiedlicher Dichte** unter Verwendung der Snowsound®-Technologie gepolstert. Oberfläche aus Polyesterstoff Trevira CS®. Ausgestattet mit einer Montageplatte und einem verchromten Gelenk zur Befestigung an Rahmenkonstruktionen zur Deckenabhängung Art.Nr. 7FC1024-C und 7FC2024-C bzw. zur Befestigung and Standsäulen Art.Nr. 7FT3006-BO und 7FT3006-N. Das Paneel kann in jede Richtung geneigt und um 360 Grad gedreht werden.

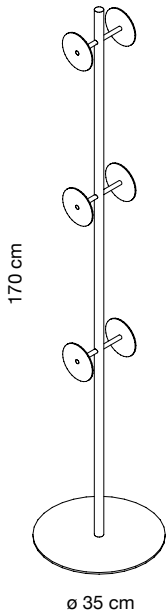

7FT3006-BO

Bianco opaco / Cromato
 Mat white / Chrome-plated
 Blanc mat / Chromé
 Blanco mate / Cromado
 Matweiß / Verchromtem

7FT3006-N

Nero / Cromato
 Black / Chrome-plated
 Noir / Chromé
 Negro / Cromado
 Schwarz / Verchromtem

Struttura in acciaio cromato con base in acciaio verniciato con polveri epossidiche colore bianco o nero per il montaggio di **6** pannelli Flap 7F100-XXXX (XXXX = Variante colore).

Structure in chrome-plated steel with mat white or black powder-coated steel base to mount **6** Flap panels code 7F100-XXXX (XXXX = Color option).

Structure en acier chromé avec base en acier peint époxy blanc mat ou noir pour l'accrochage de **6** panneaux Flap 7F100-XXXX (XXXX = option couleur)

Estructura de acero cromado con base de acero recubierto epoxi blanco mate o negro para el montaje de **6** panels Flap 7F100-XXXX (XXXX = Variante color).

Standssäule aus verchromtem Stahl mit Standfuß aus pulverbeschichtetem Stahl, matweiß oder schwarz für **6** Flap-Paneele Art. 7F100-XXXX (XXXX = Farbvariante).

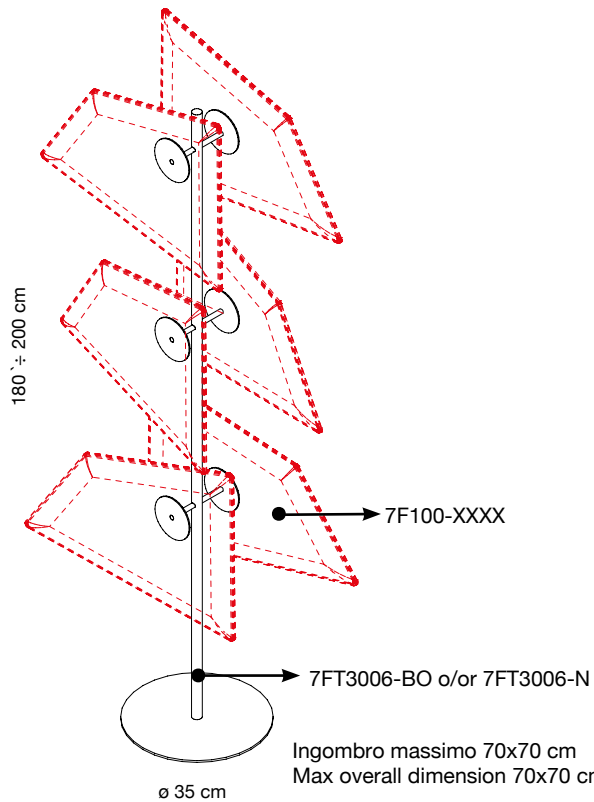

7M4002

Cromato
 Chrome-plated
 Chromé
 Cromado
 Verchromt

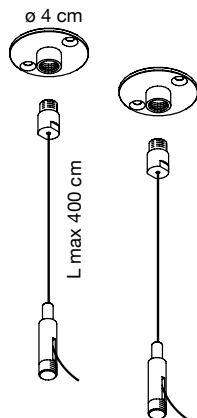

Kit per fissaggio a soffitto dei telai Flap 7FC2024-C e 7FC1024-C composto da:

2 piastre a soffitto a 2 fori - 2 cavi in acciaio - 2 attacchi a telaio

Kit for the ceiling fixing of frames Flap 7FC2024-C and 7FC1024-C composed of: 2 ceiling plates with 2 holes - 2 steel cables - 2 hangings

Kit d'accrochage au plafond pour châssis Flap 7FC2024-C et 7FC1024-C composé de:

2 platines pour plafond à 2 trous - 2 câbles en acier - 2 accrochages

Kit para el montaje al techo de bastidor Flap 7FC2024-C y 7FC1024-C compuesto por:

2 placas de techo con 2 huecos - 2 cables de acero, 2 enganches

Set für die Deckenbefestigung der netzartigen Struktur Flap 7FC2024-C und 7FC1024-C, bestehend aus:

2 Deckenmontageplatten mit 2 Befestigungsbohrungen, 2 Stahlseile, 2 Befestigungen

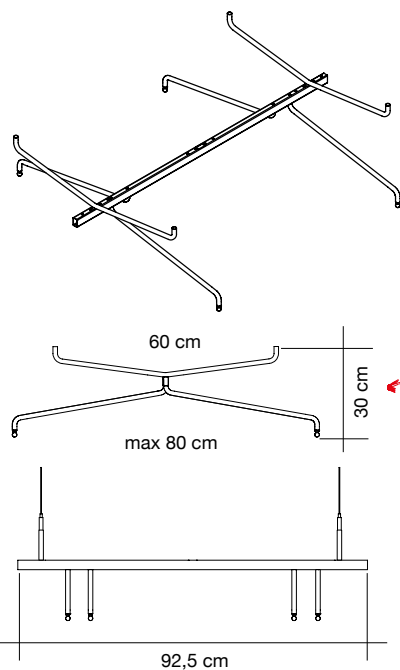

7FC2024-C

Cromato
 Chrome-plated
 Chromé
 Cromado
 Verchromt

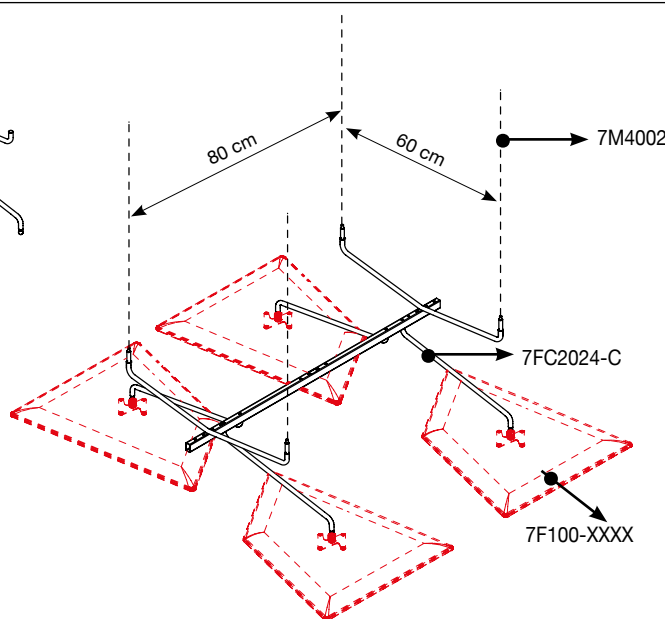

Telaio in acciaio cromato per appendimento a soffitto di 4 pannelli Flap cod. 7F100-XXXX (XXXX = Variante colore).

Telaio singolo, **NON MODULARE**. Per utilizzo in composizioni singole.

Chrome-plated frame for fixing to the ceiling four Flap panels code 7F100-XXX (XXXX = Color option).

Single frame, **NOT MODULAR**. For use in single structures.

Châssis en acier chromé pour l'accrochage au plafond de 4 panneaux Flap code 7F100-XXXX (XXXX = option couleur)

Châssis simple, **NON MODULABLE**. Pour compositions simples.

Bastidor de acero cromado para fijación al techo de 4 paneles Flap cod. 7F100-XXXX (XXXX = Variante color).

Bastidor solo, **NO MODULAR**, para utilización con composiciones individuales.

Verchromte Halterung zur Deckenmontage von vier Flap Paneelen Art.Nr. 7F100-XXX (XXXX = Farbvariante).

Einzelne Halterung, **NICHT MODULAR**. Zur Verwendung in Einzelkonstruktionen.

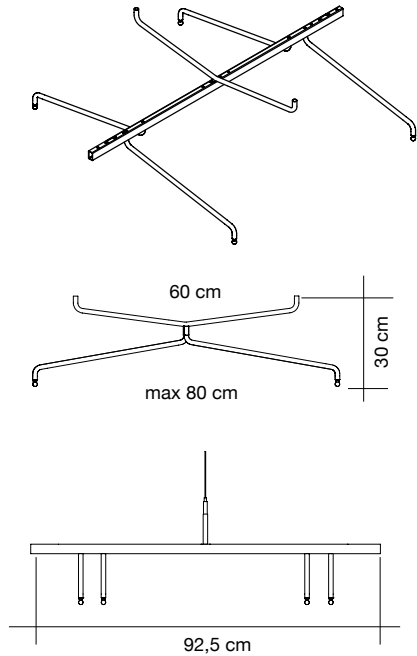

7FC1024-C
Cromato
Chrome-plated
Chromé
Cromado
Verchromt

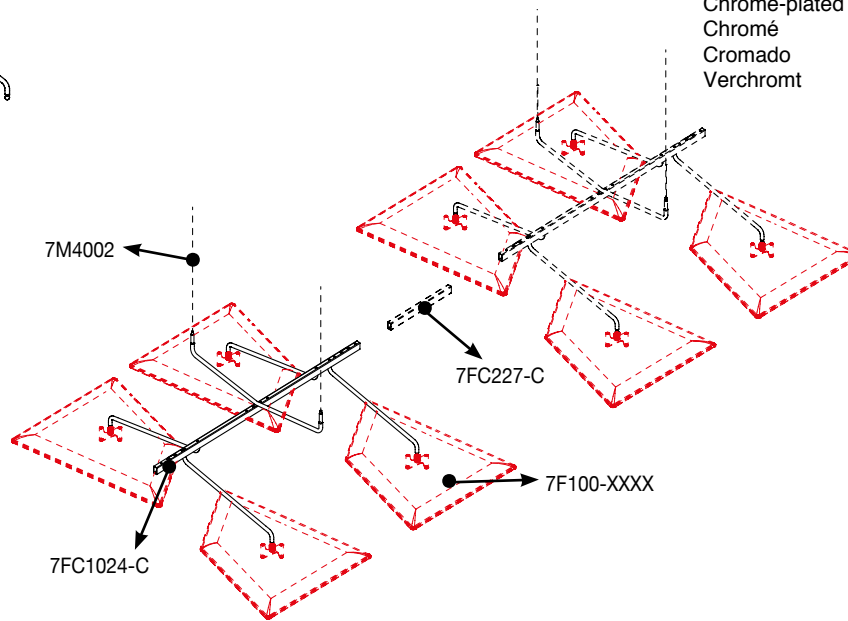

Telaio in acciaio cromato per appendimento a soffitto di 4 pannelli Flap cod. 7F100-XXXX (XXXX = Variante colore).
Telaio **MODULARE**, per utilizzo in composizioni collegate in linea mediante giunto lineare 7FC227-C.

Chrome-plated frame for fixing to the ceiling four Flap panels code 7F100-XXX (XXXX = Color option).
MODULAR frame for use with in line compositions linked through linear joint code 7FC227-C

Châssis en acier chromé pour l'accrochage au plafond de 4 panneaux Flap code 7F100-XXXX (XXXX = option couleur).
Châssis **MODULABLE**. Pour compositions linéaires avec joint linéaire code 7FC227-C

Bastidor de acero cromado para fijación al techo de 4 paneles Flap cod. 7F100-XXXX (XXXX = Variante color).
Bastidor **MODULAR** para utilización en composiciones vinculadas en línea con enganche lineal 7FC227-C.

Verchromte Halterung zur Deckenmontage von vier Flap Paneelen Art.Nr. 7F100-XXX (XXXX = Farbvariante).
MODULARE Halterung zur Verwendung in zusammengesetzten Konstruktionen, die mit dem Reihenverbinder Art. Nr. 7FC227-C verbunden werden.

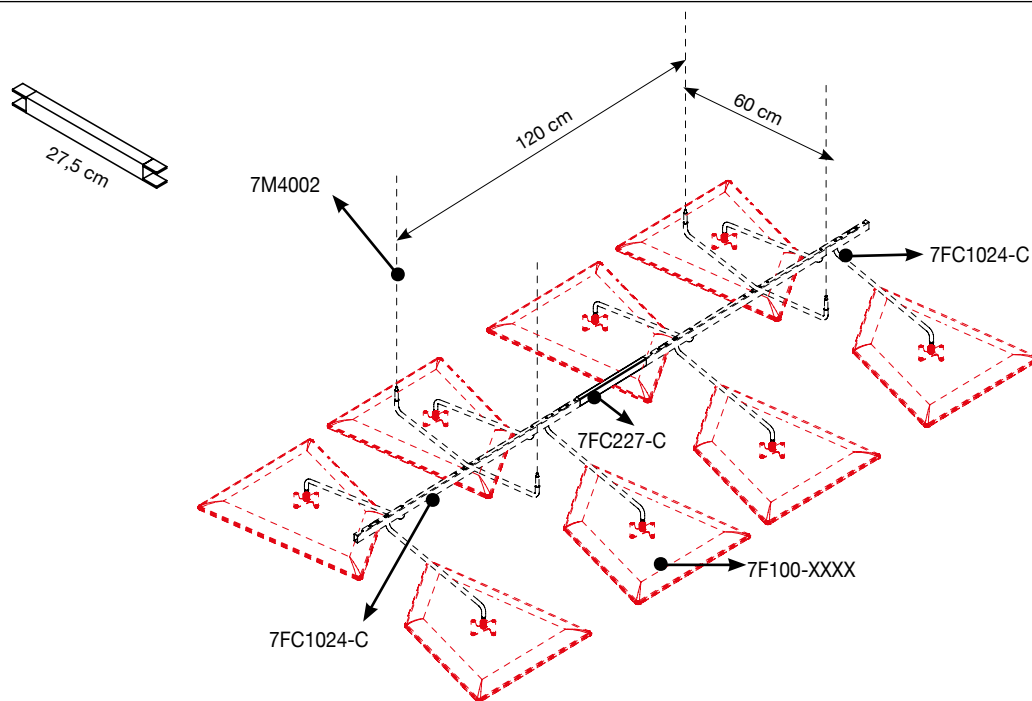

7FC227-C
Cromato
Chrome-plated
Chromé
Cromado
Verchromt

Giunto lineare in acciaio cromato per telai da 4 pannelli Flap cod. 7FC1024-C.

Chrome-plated joint for four Flap panels frame code 7FC1024-C.

Joint linéaire en acier chromé pour châssis 4 panneaux Flap code 7FC1024-C.

Enganche lineal de acero cromado para bastidores de 4 paneles Flap cod 7FC1024-C.

Reihenverbinder für Halterung 7FC1024-C.

FLAP CEILING

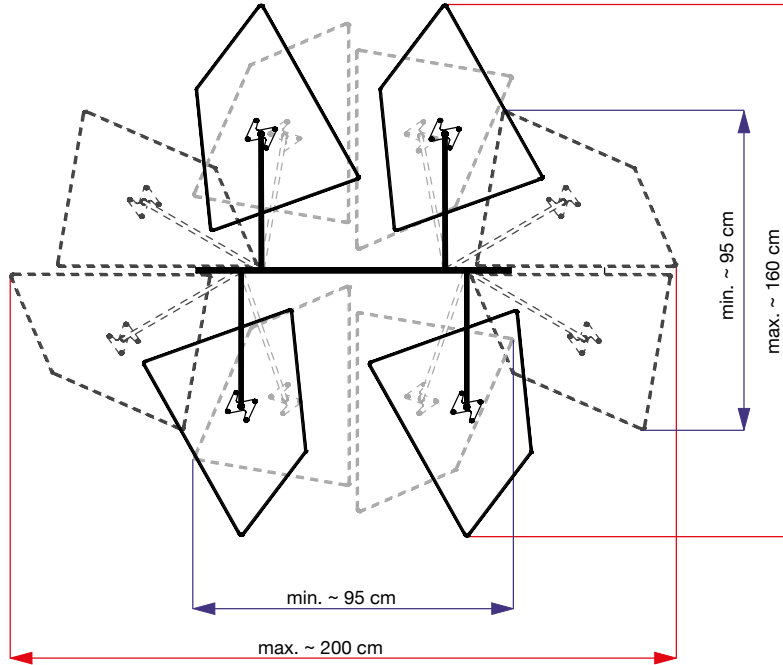

**code
7FC2024-C**

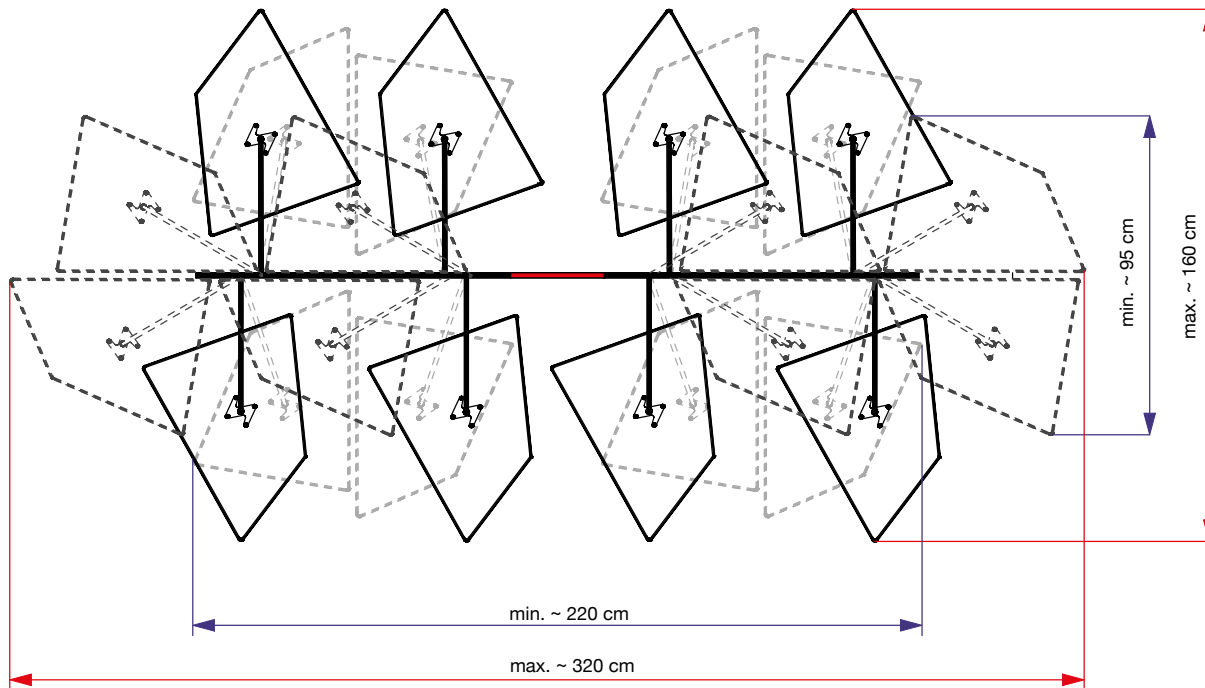

**code
7FC1024-C**

+

**code
7FC227-C**

+

**code
7FC1024-C**

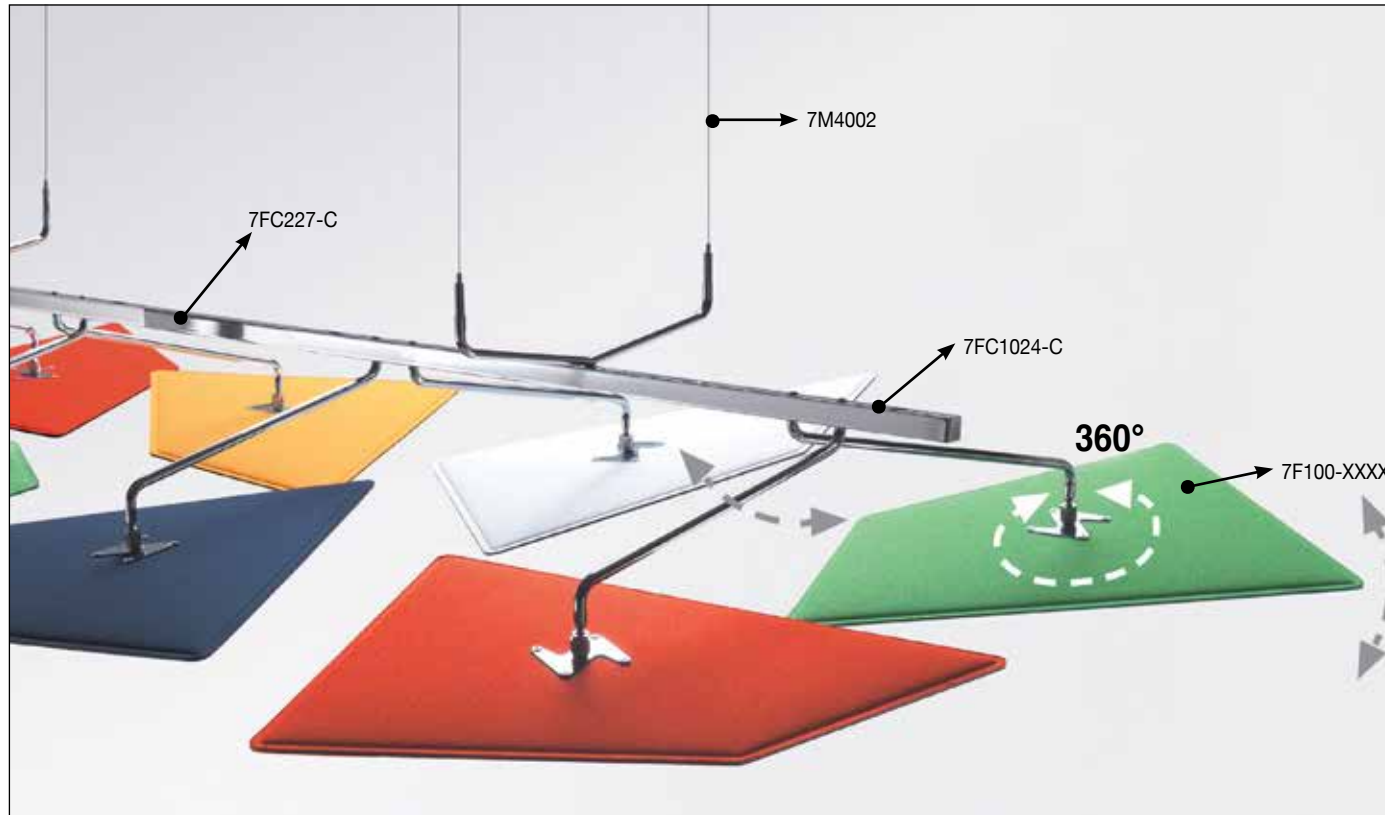

FLAP

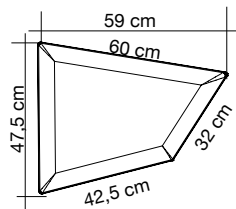
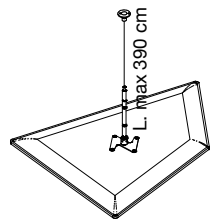

Colore
Colour

Codice/Code
Prezzo/Price

Bianco
White
Blanc
0001

7FC9100-0001

Colore
Colour

Arancione
Orange
Orange
4030

Codice/Code
Prezzo/Price

7FC9100-4030

Grigio argento
Silver grey
Gris argenté
8004

7FC9100-8004

Rosso
Red
Rouge
4027

7FC9100-4027

Grigio scuro
Dark grey
Gris foncé
8007

7FC9100-8007

Verde chiaro
Light green
Vert clair
7004

7FC9100-7004

Beige
Beige
Beige
1008

7FC9100-1008

Verde
Green
Vert
7013

7FC9100-7013

Tortora
Dove-grey
Taupe
2005

7FC9100-2005

Blu
Blue
Bleu
6071

7FC9100-6071

Giallo
Yellow
Jaune
3008

7FC9100-3008

Nero
Black
Noir
8033

7FC9100-8033

MAXI FLAP

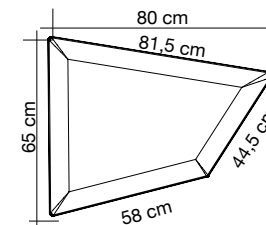
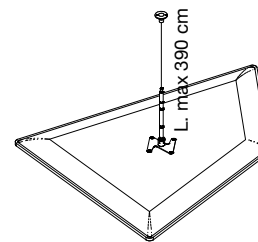

Colore
Colour

Codice/Code
Prezzo/Price

Bianco
White
Blanc
0001

7FC9200-0001

Colore
Colour

Arancione
Orange
Orange
4030

Codice/Code
Prezzo/Price

7FC9200-4030

Grigio argento
Silver grey
Gris argenté
8004

7FC9200-8004

Rosso
Red
Rouge
4027

7FC9200-4027

Grigio scuro
Dark grey
Gris foncé
8007

7FC9200-8007

Verde chiaro
Light green
Vert clair
7004

7FC9200-7004

Beige
Beige
Beige
1008

7FC9200-1008

Verde
Green
Vert
7013

7FC9200-7013

Tortora
Dove-grey
Taupe
2005

7FC9200-2005

Blu
Blue
Bleu
6071

7FC9200-6071

Giallo
Yellow
Jaune
3008

7FC9200-3008

Nero
Black
Noir
8033

7FC9200-8033

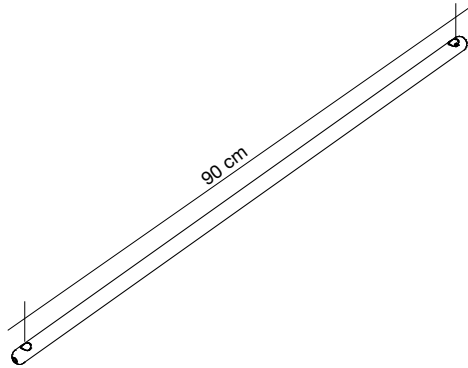

7FT90-C
Cromato
Chrome-plated
Chromé
Cromado
Verchromt

Barra di collegamento in acciaio cromato
Chrome-plated steel connecting rod
Barre de liaison en acier chromé
Barra de acoplamiento de acero cromado
Chromstahl-Verbindungsstange

Descrizione pannello
Panel description

Pannello con imbottitura interna in poliester a **densità variabile** Snowsound® Technology. Rivestimento esterno in tessuto di poliester Trevira CS®. Piastra e snodo in acciaio cromato. Astina cromata con sistema di regolazione dell'altezza del cavo. Completo di kit per fissaggio a soffitto composto da piastra a soffitto a 2 fori e cavo in acciaio. Il pannello è inclinabile in tutte le direzioni e può ruotare di 360°.

Panel with polyester internal padding with Snowsound® Technology **variable density**. Polyester covering in Trevira CS® fabric. Chrome-plated steel plate and joint. Chrome-plated rod with cable height adjustment system. Equipped with Kit for the ceiling fixing composed of: ceiling plate with 2 holes and steel cable. The panel can be tilted in any direction and can rotate 360 degrees.

Panneau avec rembourrage interne en polyester à **densité variable** Snowsound® Technology. Revêtement externe en tissu de polyester Trevira CS®. Platine et articulation en acier chromé. Tige chromée avec système de réglage de la hauteur du câble. Fourni avec kit d'accrochage au plafond composé de plaque pour plafond à 2 trous et câble en acier. Le panneau peut être incliné dans toutes les directions et pivoter sur 360°.

Panel con acolchado interior de poliéster de **densidad variable** Snowsound® Technology. Revestimiento exterior en tejido de poliéster Trevira CS®. Placa y articulación de acero cromado. Varilla cromada con sistema de ajuste de la altura del cable. Completo de kit para el montaje al techo compuesto por placa de techo con 2 huecos y cable de acero. El panel es inclinable en todas direcciones y puede rotar a 360°.

Panel mit Polyester-Füllmaterial von **unterschiedlicher Dichte** Snowsound® Technology. Polyester-Bezug aus Trevira CS®-Material. Platte und Gelenk aus Chromstahl. Verchromter Stab mit System zur Regelung der Kabelhöhe. Ausgestattet mit Set für die Deckenbefestigung bestehend aus Deckenmontageplatten mit 2 Befestigungsbohrungen und Stahlseile. Das Paneel kann in jede Richtung geneigt und um 360 Grad gedreht werden.

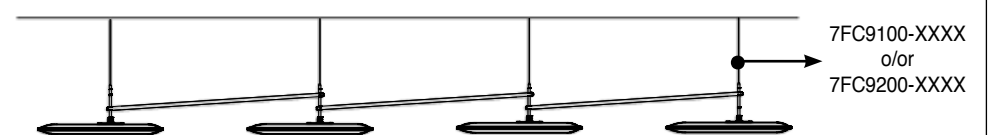
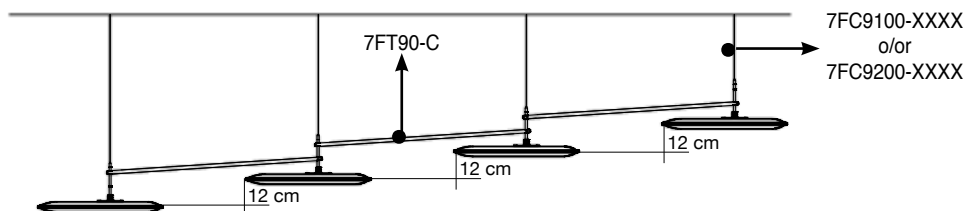

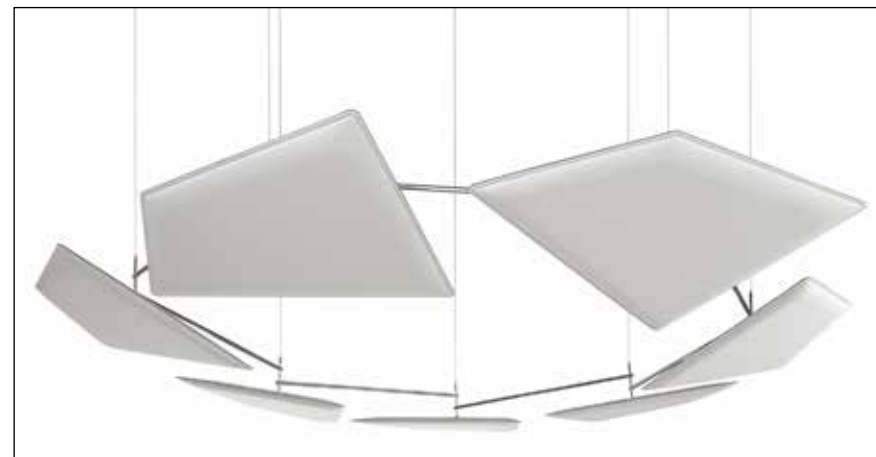
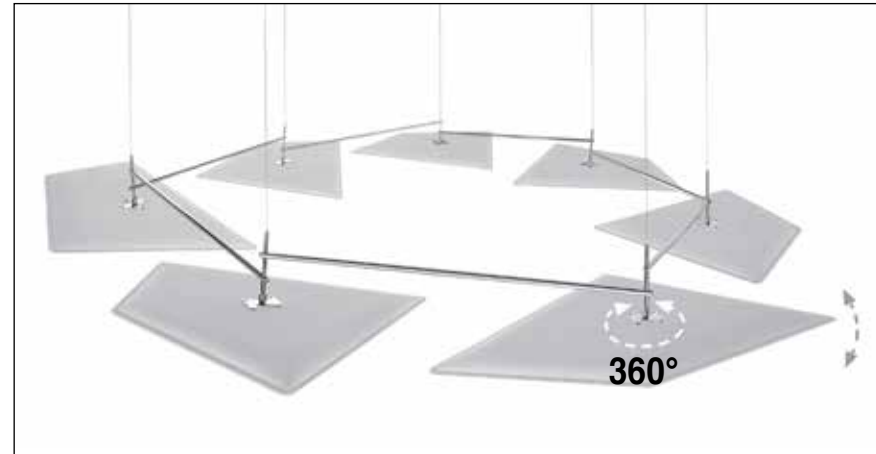
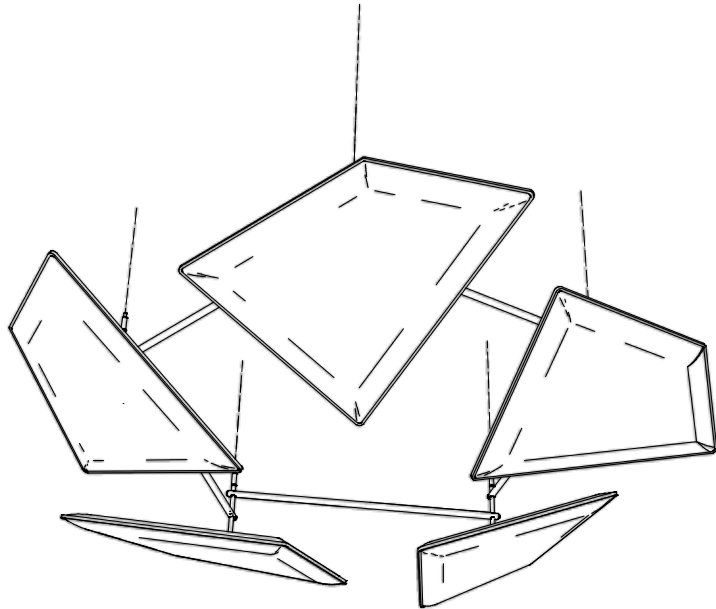

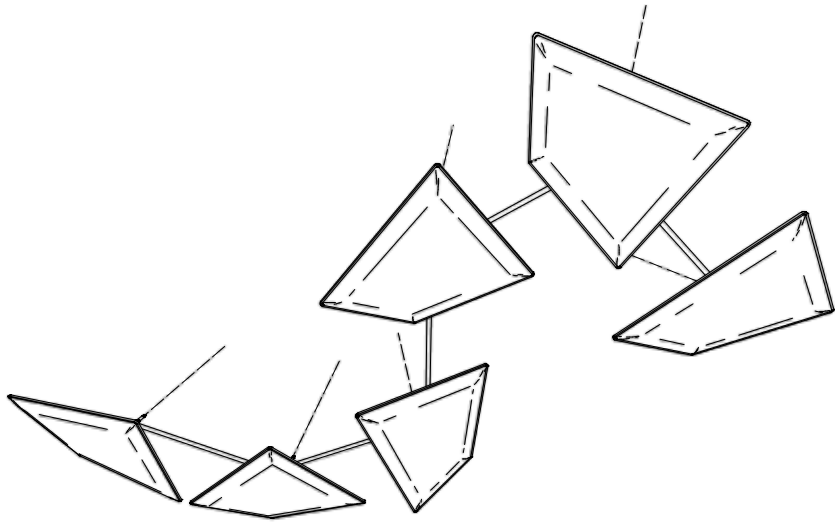

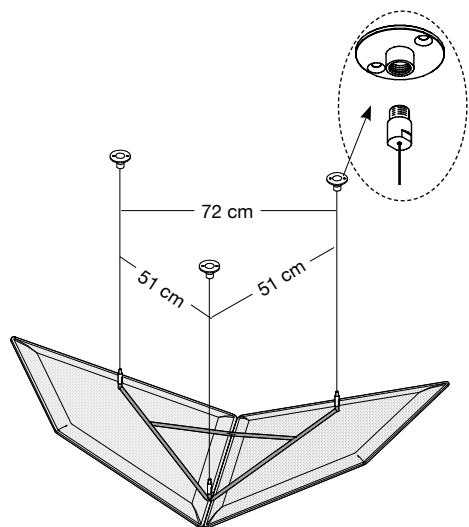

Colore
Colour

Bianco
White
Blanc
0001

Codice/Code
Prezzo/Price

7FV3002-0001

Colore
Colour

Arancione
Orange
Orange
4030

Codice/Code
Prezzo/Price

7FV3002-4030

Grigio argento
Silver grey
Gris argenté
8004

7FV3002-8004

Rosso
Red
Rouge
4027

7FV3002-4027

Grigio scuro
Dark grey
Gris foncé
8007

7FV3002-8007

Verde chiaro
Light green
Vert clair
7004

7FV3002-7004

Beige
Beige
Beige
1008

7FV3002-1008

Verde
Green
Vert
7013

7FV3002-7013

Tortora
Dove-grey
Taupe
2005

7FV3002-2005

Blu
Blue
Bleu
6071

7FV3002-6071

Giallo
Yellow
Jaune
3008

7FV3002-3008

Nero
Black
Noir
8033

7FV3002-8033

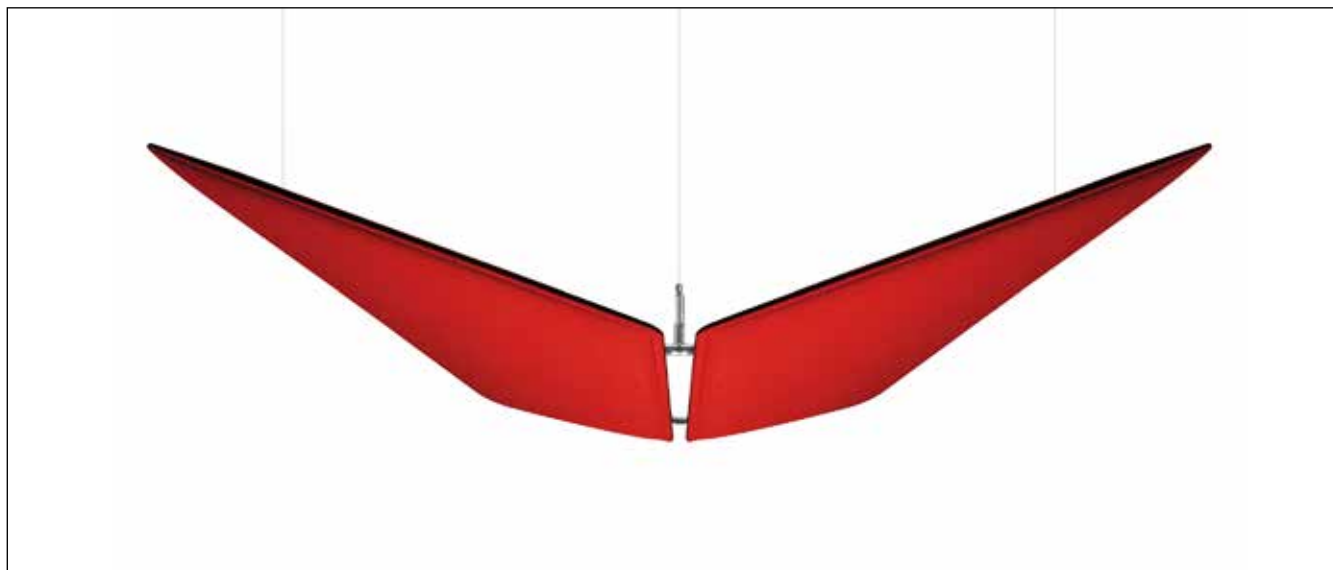

Descrizione
Description

Pannelli con imbottitura interna in poliester a **densità variabile** Snowsound® Technology. Rivestimento esterno in tessuto di poliester Trevira CS®. Completi di struttura in acciaio cromato e kit per fissaggio a soffitto composto da: 3 piastre a soffitto a 2 fori - 3 cavi in acciaio - 3 attacchi per telaio.

Panel with polyester internal padding with Snowsound® Technology **variable density**. Polyester covering in Trevira CS® fabric. Equipped with chrome-plated steelframe and Kit for the ceiling fixing composed of: 3 ceiling plates with 2 holes - 3 steel cables, 3 hangings for frame.

Panneau avec rembourrage interne en polyester à **densité variable** Snowsound® Technology. Revêtement externe en tissu de polyester Trevira CS®. Fourni avec structure en acier chromé et kit d'accrochage au plafond composé de: 3 platines pour plafond à 2 trous - 3 câbles en acier - 3 accrochages pour cadre

Panel con acolchado interior de poliéster de **densidad variable** Snowsound® Technology. Revestimiento exterior en tejido de poliéster Trevira CS®. Completo de estructura de acero cromado y kit para el montaje al techo compuesto por: 3 placas de techo con 2 huecos - 3 cables de acero - 3 enganches para bastidor.

Panel mit Polyester-Füllmaterial von **unterschiedlicher Dichte** Snowsound® Technology. Polyester-Bezug aus Trevira CS®-Material. Ausgestattet mit Gestell aus verchromtem Stahl und Set für die Deckenbefestigung bestehend aus: 3 Deckenmontageplatten mit 2 Befestigungsbohrungen, 3 Stahlseile, 3 Befestigungen für den Rahmen.

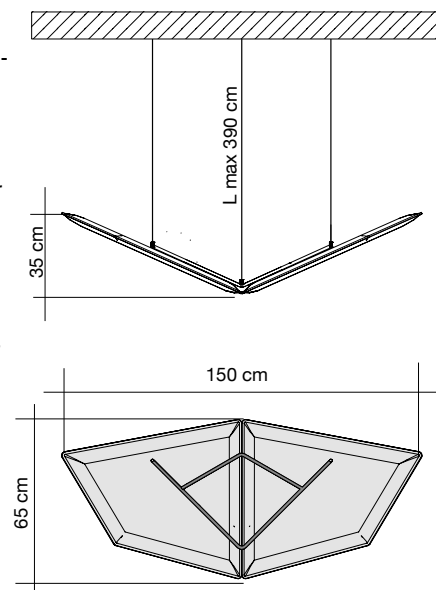

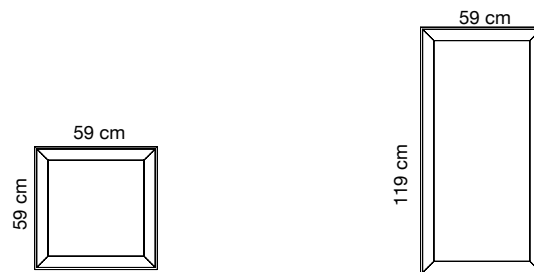

Colore Colour	Codice/Code Prezzo/Price	Codice/Code Prezzo/Price
<div style="background-color: #e0e0e0; padding: 2px;">Bianco</div> <div style="background-color: #e0e0e0; padding: 2px;">White</div> <div style="background-color: #e0e0e0; padding: 2px;">Blanc</div> 0001	710606-0001	711206-0001
<div style="background-color: #d3d3d3; padding: 2px;">Grigio argento</div> <div style="background-color: #d3d3d3; padding: 2px;">Silver grey</div> <div style="background-color: #d3d3d3; padding: 2px;">Gris argenté</div> 8004	710606-8004	711206-8004
<div style="background-color: #808080; padding: 2px;">Grigio scuro</div> <div style="background-color: #808080; padding: 2px;">Dark grey</div> <div style="background-color: #808080; padding: 2px;">Gris foncé</div> 8007	710606-8007	711206-8007
<div style="background-color: #d2b48c; padding: 2px;">Beige</div> <div style="background-color: #d2b48c; padding: 2px;">Beige</div> <div style="background-color: #d2b48c; padding: 2px;">Beige</div> 1008	710606-1008	711206-1008
<div style="background-color: #a9a9a9; padding: 2px;">Tortora</div> <div style="background-color: #a9a9a9; padding: 2px;">Dove-grey</div> <div style="background-color: #a9a9a9; padding: 2px;">Taupe</div> 2005	710606-2005	711206-2005
<div style="background-color: #ffd700; padding: 2px;">Giallo</div> <div style="background-color: #ffd700; padding: 2px;">Yellow</div> <div style="background-color: #ffd700; padding: 2px;">Jaune</div> 3008	710606-3008	711206-3008

Pannello con imbottitura interna in poliester a **densità variabile** Snowsound® Technology. Rivestimento esterno in tessuto di poliester Trevira CS®.

Panel with polyester internal padding with Snowsound® Technology **variable density**. Polyester covering in Trevira CS® fabric.

Panneau avec rembourrage interne en polyester à **densité variable** Snowsound® Technology. Revêtement externe en tissu de polyester Trevira CS®.

Panel con acolchado interior de poliéster de **densidad variable** Snowsound® Technology. Revestimiento exterior en tejido de poliéster Trevira CS®.

Paneel mit Polyester-Füllmaterial von **unterschiedlicher Dichte** Snowsound® Technology. Polyester-Bezug aus Trevira CS®-Material.



Colore Colour	Codice/Code Prezzo/Price	Codice/Code Prezzo/Price
Arancione Orange Orange 4030	710606-4030	711206-4030
Rosso Red Rouge 4027	710606-4027	711206-4027
Verde chiaro Light green Vert clair 7004	710606-7004	711206-7004
Mattone Brick red Rouge brique 4086	710606-4086	711206-4086
Azzurro Light blue Bleu clair 6046	710606-6046	711206-6046
Ottanio Teal Sarcelle 6075	710606-6075	711206-6075

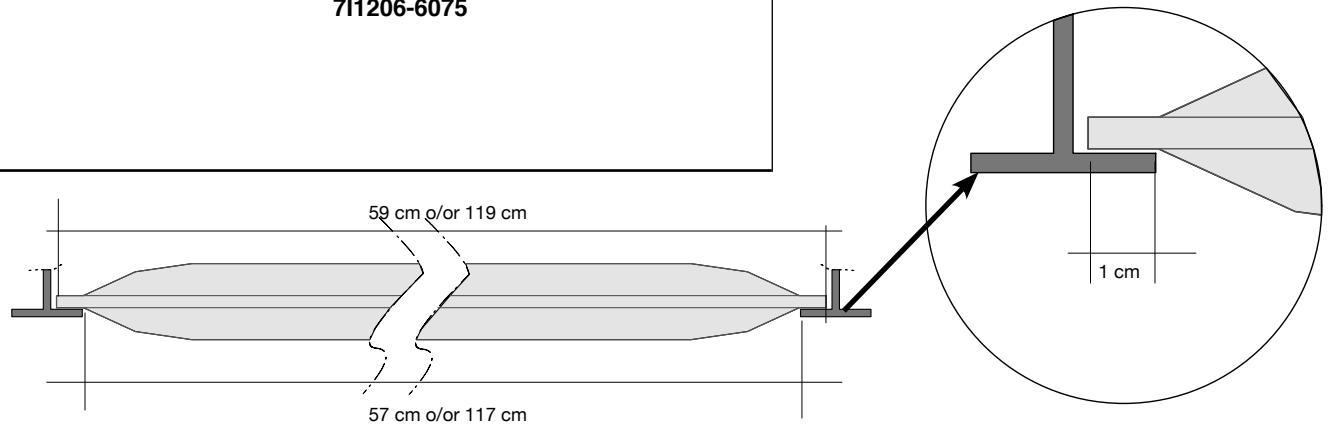

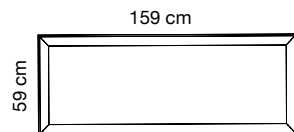

Colore Colour	Codice/Code Prezzo/Price
Bianco White Blanc	0001 7BL1606-0001
Grigio argento Silver grey Gris argenté	8004 7BL1606-8004
Grigio scuro Dark grey Gris foncé	8007 7BL1606-8007
Beige Beige Beige	1008 7BL1606-1008
Tortora Dove-grey Taupe	2005 7BL1606-2005
Giallo Yellow Jaune	3008 7BL1606-3008
Arancione Orange Orange	4030 7BL1606-4030
Rosso Red Rouge	4027 7BL1606-4027
Verde chiaro Light green Vert clair	7004 7BL1606-7004
Mattone Brick red Rouge brique	4086 7BL1606-4086
Azzurro Light blue Bleu clair	6046 7BL1606-6046
Ottanio Teal Sarcelle	6075 7BL1606-6075
Bianco ghiaccio Cool white Blanc glacier	8002 7BL1606-8002

Pannello con imbottitura interna in poliester a **densità variabile** Snowsound® Technology. Rivestimento esterno in tessuto di poliester Trevira CS®.

Panel with polyester internal padding with Snowsound® Technology **variable density**. Polyester covering in Trevira CS® fabric.

Panneau avec rembourrage interne en polyester à **densité variable** Snowsound® Technology. Revêtement externe en tissu de polyester Trevira CS®.

Panel con acolchado interior de poliéster de **densidad variable** Snowsound® Technology. Revestimiento exterior de tejido de poliéster Trevira CS®.

Paneel mit Polyester-Füllmaterial von **unterschiedlicher Dichte** Snowsound® Technology. Polyester-Bezug aus Trevira CS®-Material.



7BL160-BO
Bianco opaco
Mat white
Blanc mat
Blanco mate
Mattweiß

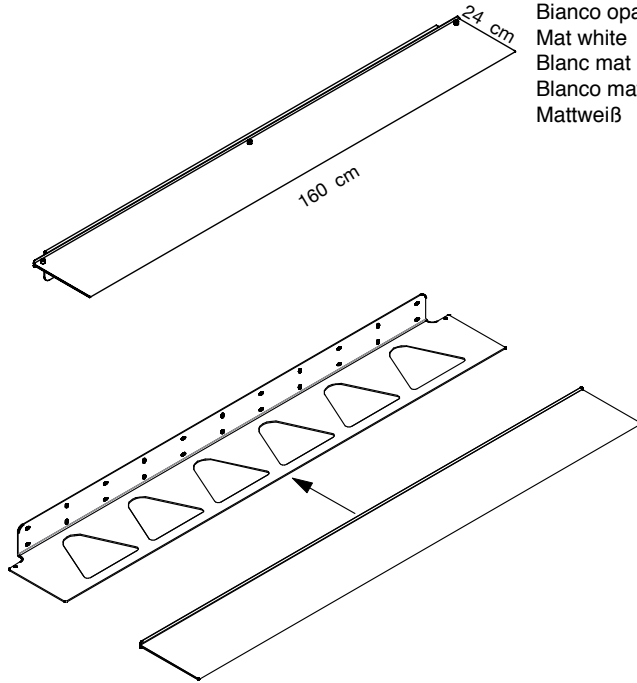

Mensola in acciaio verniciato con polveri epossidiche

Powder coated steel shelf

Tablette en acier peint en époxy

Estante en acero recubierto con polvos epoxidicos

Regalboden aus Epoxypulver beschichtetem Stahl

Portata massima 30 Kg per piano
Maximum load 30 Kg for 1 shelf

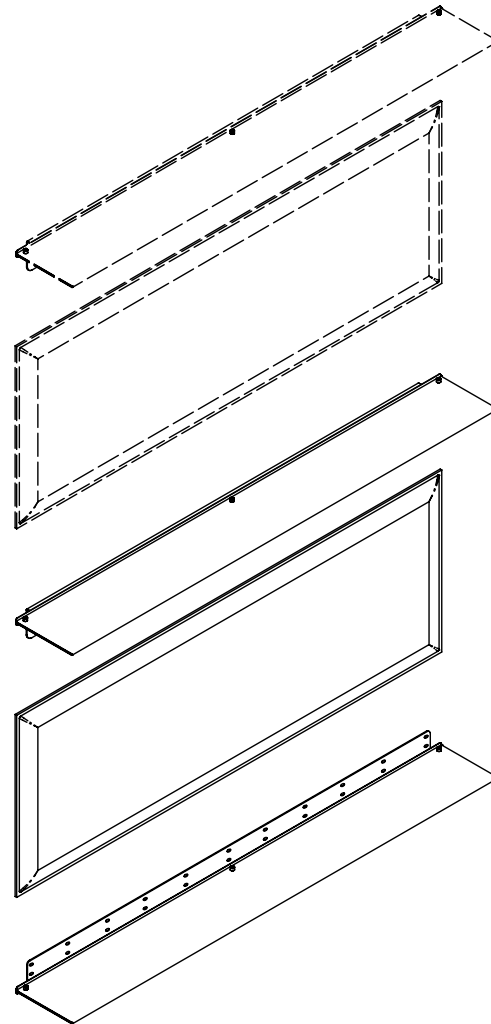

119 cm

7SG16/55-0001 Bianco
White
Blanc
Blanco
Weiß

Pannello con imbottitura interna in poliester a **densità variabile**. Rivestimento esterno in tessuto di poliester Trevira CS®. Applicabile a parete. **(Attacchi non inclusi - vedi pag. 151).**

Panel with internal padding in **variable density** polyester. Outer cover in Trevira CS® polyester fabric. Wall mounting. **(Fixings not included - see page 151).**

Panneau avec rembourrage interne en polyester à **densité variable**. Revêtement externe en tissu de polyester Trevira CS®. Application au mur. **(Fixations pas inclus - voir page 151).**

Panel con acolchado interior de poliéster de **densidad variable**. Revestimiento exterior de tejido de poliéster Trevira CS®. Aplicación a pared. **(Fijaciones no incluydas - pag. 151)**

Paneel mit Polyester-Füllmaterial von **unterschiedlicher Dichte**. Polyester-Bezug aus Trevira CS®-Material. Wandanwendung. **(Befestigungen nicht inkludiert - Seite 151).**



Senza titolo / Untitled 1955-2017

159 cm

119 cm

7SG16/55-4030 Arancione
Orange
Orange
Anaranjado
Orange

Pannello con imbottitura interna in poliester a **densità variabile**. Rivestimento esterno in tessuto di poliester Trevira CS®. Applicabile a parete. **(Attacchi non inclusi - vedi pag. 151).**

Panel with internal padding in **variable density** polyester. Outer cover in Trevira CS® polyester fabric. Wall mounting. **(Fixings not included - see page 151).**

Panneau avec rembourrage interne en polyester à **densité variable**. Revêtement externe en tissu de polyester Trevira CS®. Application au mur. **(Fixations pas inclus - voir page 151).**

Panel con acolchado interior de poliéster de **densidad variable**. Revestimiento exterior de tejido de poliéster Trevira CS®. Aplicación a pared. **(Fijaciones no incluydas - pag. 151)**

Paneel mit Polyester-Füllmaterial von **unterschiedlicher Dichte**. Polyester-Bezug aus Trevira CS®-Material. Wandanwendung. **(Befestigungen nicht inkludiert - Seite 151).**



Senza titolo / Untitled 1955-2017

159 cm

119 cm

7SG16/55-4027 Rosso
Red
Rouge
Rojo
Rot

Pannello con imbottitura interna in poliester a **densità variabile**. Rivestimento esterno in tessuto di poliester Trevira CS®. Applicabile a parete. **(Attacchi non inclusi - vedi pag. 151).**

Panel with internal padding in **variable density** polyester. Outer cover in Trevira CS® polyester fabric. Wall mounting. **(Fixings not included - see page 151).**

Panneau avec rembourrage interne en polyester à **densité variable**. Revêtement externe en tissu de polyester Trevira CS®. Application au mur. **(Fixations pas inclus - voir page 151).**

Panel con acolchado interior de poliéster de **densidad variable**. Revestimiento exterior de tejido de poliéster Trevira CS®. Aplicación a pared. **(Fijaciones no incluydas - pag. 151)**

Paneel mit Polyester-Füllmaterial von **unterschiedlicher Dichte**. Polyester-Bezug aus Trevira CS®-Material. Wandanwendung. **(Befestigungen nicht inkludiert - Seite 151).**



Senza titolo / Untitled 1955-2017

159 cm

119 cm

7SG16/55-8033 Nero
Black
Noir
Negro
Schwarz

Pannello con imbottitura interna in poliester a **densità variabile**. Rivestimento esterno in tessuto di poliester Trevira CS®. Applicabile a parete. **(Attacchi non inclusi - vedi pag. 151).**

Panel with internal padding in **variable density** polyester. Outer cover in Trevira CS® polyester fabric. Wall mounting. **(Fixings not included - see page 151).**

Panneau avec rembourrage interne en polyester à **densité variable**. Revêtement externe en tissu de polyester Trevira CS®. Application au mur. **(Fixations pas inclus - voir page 151).**

Panel con acolchado interior de poliéster de **densidad variable**. Revestimiento exterior de tejido de poliéster Trevira CS®. Aplicación a pared. **(Fijaciones no incluydas - pag. 151)**

Paneel mit Polyester-Füllmaterial von **unterschiedlicher Dichte**. Polyester-Bezug aus Trevira CS®-Material. Wandanwendung. **(Befestigungen nicht inkludiert - Seite 151).**



Senza titolo / Untitled 1955-2017

159 cm

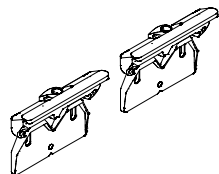

7S370-BO
 Bianco opaco
 Mat white
 Blanc mat
 Blanco mate
 Mattweiß

1 coppia / 1 pair
1 paire / 1 pare
1 Paar

Coppia attacchi a parete in zama verniciata o nichel satinata.
 Per il fissaggio a parete, è necessaria 1 coppia di attacchi per ogni pannello Snowsound Art. Per cod. 7SG16/55-0001 / 7SG16/55-4030 / 7SG16/55-4027 / 7SG16/55-8033.

Pair of wall fixings in zamac, painted or nickel satinated.
 For wall mounting, a set of two fixings is required for each Snowsound Art panel. For codes 7SG16/55-0001 / 7SG16/55-4030 / 7SG16/55-4027 / 7SG16/55-8033.



7S370-C
 Nichel satinato
 Nickel satinéd
 Nickel satinée
 Niquel satinado
 Nickel satiniert

1 coppia / 1 pair
1 paire / 1 pare
1 Paar

Paire de fixations murales en zamac peinte ou nickel satinée. Pour la fixation au mur il faut 1 paire de joints pour chaque panneau Snowsound Art. Pour réf. 7SG16/55-0001 / 7SG16/55-4030 / 7SG16/55-4027 / 7SG16/55-8033.

Set de fijaciones a pared en zamac, pintado o nichel satinado. Para montaje a pared, se necesita un set de 2 pzs. para cada panel Snowsound Art. Para cod. 7SG16/55-0001 / 7SG16/55-4030 / 7SG16/55-4027 / 7SG16/55-8033.

1 Paar Wandbefestigungen aus Zamac, lackiert oder Nickel satiniert. Für die Wandmontage wird ein Paar Befestigungen für jedes Snowsound Art Paneel benötigt. Für Art. 7SG16/55-0001 / 7SG16/55-4030 / 7SG16/55-4027 / 7SG16/55-8033.



159 cm



Senza titolo / Untitled 1937-2017

7SG16/37-0001 Bianco
White
Blanc
Blanco
Weiß

Pannello con imbottitura interna in poliester a **densità variabile**. Rivestimento esterno in tessuto di poliester Trevira CS®. Applicabile a parete o a soffitto. **(Attacchi non inclusi - vedi pag. 153).**

Panel with internal padding in **variable density** polyester. Outer cover in Trevira CS® polyester fabric. Wall or ceiling mounting. **(Fixings not included - see page 153).**

Panneau avec rembourrage interne en polyester à **densité variable**. Revêtement externe en tissu de polyester Trevira CS®. Application mur ou plafond. **(Fixations pas inclus - voir page 153).**

Panel con acolchado interior de poliéster de **densidad variable**. Revestimiento exterior de tejido de poliéster Trevira CS®. Aplicación pared o techo. **(Fijaciones no incluydas - page 153)**

Panel mit Polyester-Füllmaterial von **unterschiedlicher Dichte**. Polyester-Bezug aus Trevira CS®-Material. Decke-oder Wandanwendung. **(Befestigungen nicht inkludiert - Seite 153).**

159 cm

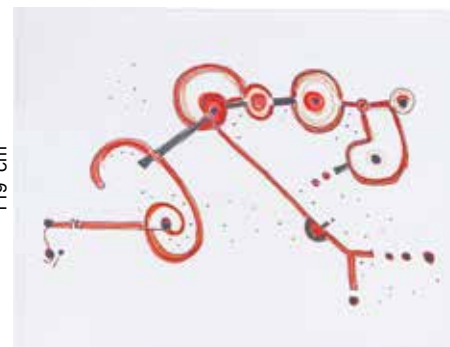

Senza titolo / Untitled 1991

7SG16/91-0001 Bianco
White
Blanc
Blanco
Weiß

Pannello con imbottitura interna in poliester a **densità variabile**. Rivestimento esterno in tessuto di poliester Trevira CS®. Applicabile a parete o a soffitto. **(Attacchi non inclusi - vedi pag. 153).**

Panel with internal padding in **variable density** polyester. Outer cover in Trevira CS® polyester fabric. Wall or ceiling mounting. **(Fixings not included - see page 153).**

Panneau avec rembourrage interne en polyester à **densité variable**. Revêtement externe en tissu de polyester Trevira CS®. Application mur ou plafond. **(Fixations pas inclus - voir page 153).**

Panel con acolchado interior de poliéster de **densidad variable**. Revestimiento exterior de tejido de poliéster Trevira CS®. Aplicación pared o techo. **(Fijaciones no incluydas - page 153)**

Panel mit Polyester-Füllmaterial von **unterschiedlicher Dichte**. Polyester-Bezug aus Trevira CS®-Material. Decke-oder Wandanwendung. **(Befestigungen nicht inkludiert - Seite 153).**

119 cm



Senza titolo / Untitled 1998

7SG12/98-0001 Bianco
White
Blanc
Blanco
Weiß

Pannello con imbottitura interna in poliester a **densità variabile**. Rivestimento esterno in tessuto di poliester Trevira CS®. Applicabile a parete o a soffitto. **(Attacchi non inclusi - vedi pag. 153).**

Panel with internal padding in **variable density** polyester. Outer cover in Trevira CS® polyester fabric. Wall or ceiling mounting. **(Fixings not included - see page 153).**

Panneau avec rembourrage interne en polyester à **densité variable**. Revêtement externe en tissu de polyester Trevira CS®. Application mur ou plafond. **(Fixations pas inclus - voir page 153).**

Panel con acolchado interior de poliéster de **densidad variable**. Revestimiento exterior de tejido de poliéster Trevira CS®. Aplicación pared o techo. **(Fijaciones no incluydas - page 153)**

Panel mit Polyester-Füllmaterial von **unterschiedlicher Dichte**. Polyester-Bezug aus Trevira CS®-Material. Decke-oder Wandanwendung. **(Befestigungen nicht inkludiert - Seite 153).**

119 cm



Senza titolo / Untitled 1998

7SG12/98-8033 Nero
Black
Noir
Negro
Schwarz

Pannello con imbottitura interna in poliester a **densità variabile**. Rivestimento esterno in tessuto di poliester Trevira CS®. Applicabile a parete o a soffitto. **(Attacchi non inclusi - vedi pag. 153).**

Panel with internal padding in **variable density** polyester. Outer cover in Trevira CS® polyester fabric. Wall or ceiling mounting. **(Fixings not included - see page 153).**

Panneau avec rembourrage interne en polyester à **densité variable**. Revêtement externe en tissu de polyester Trevira CS®. Application mur ou plafond. **(Fixations pas inclus - voir page 153).**

Panel con acolchado interior de poliéster de **densidad variable**. Revestimiento exterior de tejido de poliéster Trevira CS®. Aplicación pared o techo. **(Fijaciones no incluydas - page 153)**

Panel mit Polyester-Füllmaterial von **unterschiedlicher Dichte**. Polyester-Bezug aus Trevira CS®-Material. Decke-oder Wandanwendung. **(Befestigungen nicht inkludiert - Seite 153).**

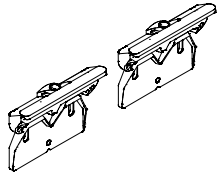

7S370-BO

Bianco opaco
Mat white
Blanc mat
Blanco mate
Mattweiß

1 coppia / 1 pair
1 paire / 1 pare
1 Paar

7S370-C

Nichel satinato
Nickel satinéd
Nickel satinée
Niquel satinado
Nickel satiniert

1 coppia / 1 pair
1 paire / 1 pare
1 Paar

Coppia attacchi a parete in zama verniciata o nichel satinata. Per il fissaggio a parete, è necessaria 1 coppia di attacchi per ogni pannello Snowsound Art. Per cod. 7SG16/37-0001 / 7SG16/91-0001 / 7SG12/98-0001 / 7SG12/98-8033.

Pair of wall fixings in zamac, painted or nickel satinéd. For wall mounting, a set of two fixings is required for each Snowsound Art panel. For codes 7SG16/37-0001 / 7SG16/91-0001 / 7SG12/98-0001 / 7SG12/98-8033.

Paire de fixations murales en zamac peinte ou nickel satinée. Pour fixation au mur utiliser 1 paire de joints pour chaque panneau Snowsound Art. Pour réf. 7SG16/37-0001 / 7SG16/91-0001 / 7SG12/98-0001 / 7SG12/98-8033.

Set de fijaciones a pared en zamac, pintado o niquel satinado. Para montaje a pared, se necesita un set de 2 pzs. para cada panel Snowsound Art. Para cod. 7SG16/37-0001 / 7SG16/91-0001 / 7SG12/98-0001 / 7SG12/98-8033.

1 Paar Wandbefestigungen aus Zamac, lackiert oder Nickel satiniert. Für die Wandmontage wird ein Paar Befestigungen für jedes Snowsound Art Paneel benötigt. Für Art. 7SG16/37-0001 / 7SG16/91-0001 / 7SG12/98-0001 / 7SG12/98-8033.

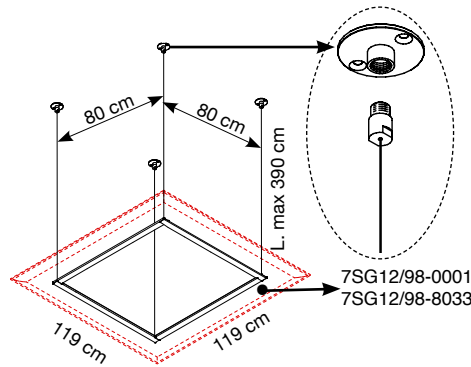

7SG12/98-0001
7SG12/98-8033



Per cod. / For codes / Pour réf. /
Para code / Fur Art.
7SG12/98-0001 / 7SG12/98-8033.

Peso 8,5 Kg (struttura + pannello)
Weight 8,5 Kg (frame + panel)

7OSF120

Struttura in acciaio e kit per fissaggio a soffitto composto da: 4 piastre a soffitto a 2 fori - 4 cavi in acciaio - 4 attacchi per telaio. Per il fissaggio a soffitto pannelli Snowsound Art 119x119 cm. Per cod. 7SG12/98-0001 / 7SG12/98-8033

Steel frame and kit for ceiling fixing composed of: 4 ceiling plates with 2 holes, 4 steel cables, 4 frame connection. For ceiling mounting of Snowsound Art panels 119x119 cm. For codes 7SG12/98-0001 / 7SG12/98-8033.

Structure en acier et kit d'accrochage au plafond composé de: 4 platines pour plafond à 2 trous - 4 câbles en acier - 4 accrochages pour cadre. Pour la fixation au plafond des panneaux Snowsound Art 119x119 cm.

Estructura de acero y kit para el montaje al techo compuesto por: 4 placas de techo con 2 huecos - 4 cables de acero - 4 enganches para bastidor. Para montaje a techo del panel de 119x119 Snowsound Art.

Gestell aus Stahl und Set für die Deckenbefestigung bestehend aus: 4 Deckenmontageplatten mit 2 Befestigungsbohrungen, 4 Stahlseile, 4 Befestigungen für den Rahmen. Für die Deckenmontage der Snowsound Art Paneele 119 x 119 cm.

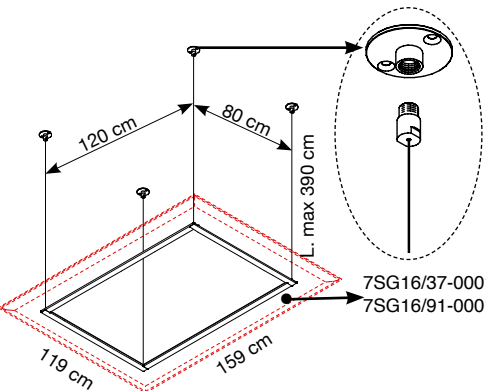

7SG16/37-0001
7SG16/91-0001



Per cod. / For codes / Pour réf. /
Para code / Fur Art.
7SG16/37-0001 / 7SG16/91-0001

Peso 10,5 Kg (struttura + pannello)
Weight 10,5 Kg (frame + panel)

7OSF160

Struttura in acciaio e kit per fissaggio a soffitto composto da: 4 piastre a soffitto a 2 fori - 4 cavi in acciaio - 4 attacchi per telaio. Per il fissaggio a soffitto pannelli Snowsound Art 119x159 cm. Per cod. 7SG16/37-0001 / 7SG16/91-0001

Steel frame and kit for ceiling fixing composed of: 4 ceiling plates with 2 holes, 4 steel cables, 4 frame connection. For ceiling mounting of Snowsound Art panels 119x159 cm. For codes 7SG16/37-0001 / 7SG16/91-0001

Structure en acier et kit d'accrochage au plafond composé de: 4 platines pour plafond à 2 trous - 4 câbles en acier - 4 accrochages pour cadre. Pour la fixation au plafond des panneaux Snowsound Art 119x159 cm.

Estructura de acero y kit para el montaje al techo compuesto por: 4 placas de techo con 2 huecos - 4 cables de acero - 4 enganches para bastidor. Para montaje a techo del panel de 119x159 Snowsound Art.

Gestell aus Stahl und Set für die Deckenbefestigung bestehend aus: 4 Deckenmontageplatten mit 2 Befestigungsbohrungen, 4 Stahlseile, 4 Befestigungen für den Rahmen. Für die Deckenmontage der Paneele 119 x 159 cm.

119 cm

59 cm

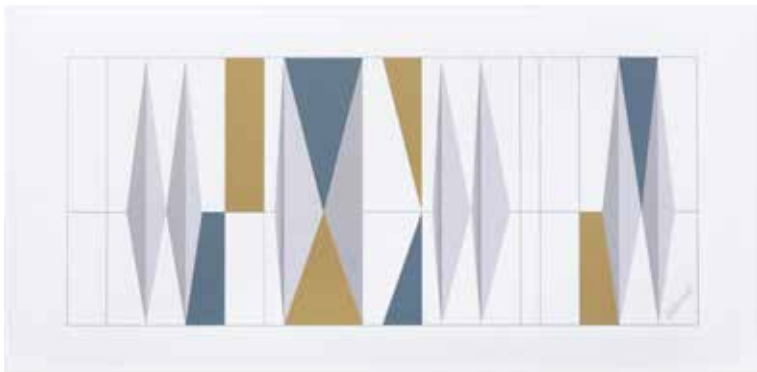

Decoro per Villa Planchart e Villa Nemazee /
Decor for Villa Planchart and Villa Nemazee, 1955-1964

7SP1206/1-0001 Bianco
White
Blanc
Blanco
Weiß

Pannello con imbottitura interna in poliester a **densità variabile**. Rivestimento esterno in tessuto di poliester Trevira CS®. Applicabile a parete. **(Attacchi non inclusi - vedi pag. 156)**.

Panel with internal padding in **variable density** polyester. Outer cover in Trevira CS® polyester fabric.

Wall mounting. **(Fixings not included - see page 156)**.

Panneau avec rembourrage interne en polyester à **densité variable**. Revêtement externe en tissu de polyester Trevira CS®. Application au mur. **(Fixations pas inclus - voir page 156)**.

Panel con acolchado interior de poliéster de **densidad variable**. Revestimiento exterior de tejido de poliéster Trevira CS®. Aplicación a pared. **(Fijaciones no incluidas - pag. 156)**

Paneel mit Polyester-Füllmaterial von **unterschiedlicher Dichte**. Polyester-Bezug aus Trevira CS®-Material. Wandanwendung. **(Befestigungen nicht inkludiert - Seite 156)**.

159 cm

119 cm

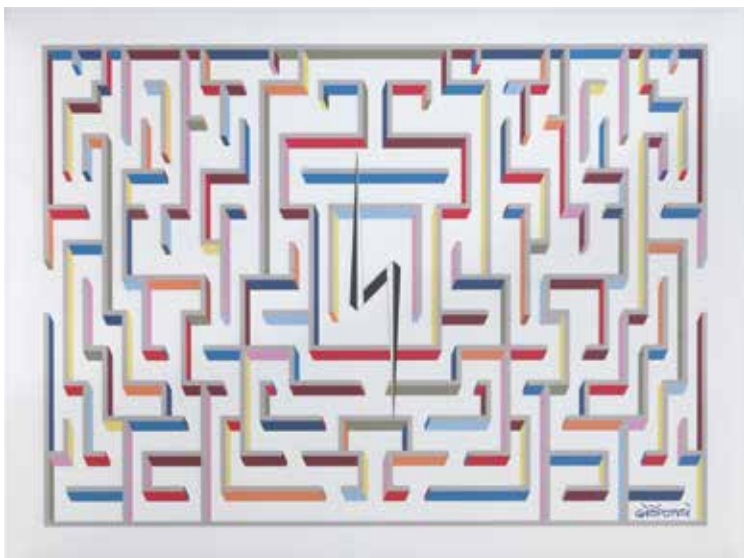

Labirinto / Labyrinth 1941-1947

7SP1216/1-0001 Bianco
White
Blanc
Blanco
Weiß

Pannello con imbottitura interna in poliester a **densità variabile**. Rivestimento esterno in tessuto di poliester Trevira CS®. Applicabile a parete. **(Attacchi non inclusi - vedi pag. 156)**.

Panel with internal padding in **variable density** polyester. Outer cover in Trevira CS® polyester fabric.

Wall mounting. **(Fixings not included - see page 156)**.

Panneau avec rembourrage interne en polyester à **densité variable**. Revêtement externe en tissu de polyester Trevira CS®. Application au mur. **(Fixations pas inclus - voir page 156)**.

Panel con acolchado interior de poliéster de **densidad variable**. Revestimiento exterior de tejido de poliéster Trevira CS®. Aplicación a pared. **(Fijaciones no incluidas - pag. 156)**

Paneel mit Polyester-Füllmaterial von **unterschiedlicher Dichte**. Polyester-Bezug aus Trevira CS®-Material. Wandanwendung. **(Befestigungen nicht inkludiert - Seite 156)**.

59 cm

7SP0606/1-0001 Bianco
White
Blanc
Blanco
Weiß



59 cm

Lettere disegnate / Drawn letters

Pannello con imbottitura interna in poliester a **densità variabile**. Rivestimento esterno in tessuto di poliester Trevira CS®. Applicabile a parete. **(Attacchi non inclusi - vedi pag. 156)**.

Panel with internal padding in **variable density** polyester. Outer cover in Trevira CS® polyester fabric. Wall mounting. **(Fixings not included - see page 156)**.

Panneau avec rembourrage interne en polyester à **densité variable**. Revêtement externe en tissu de polyester Trevira CS®. Application au mur. **(Fixations pas inclus - voir page 156)**.

Panel con acolchado interior de poliéster de **densidad variable**. Revestimiento exterior de tejido de poliéster Trevira CS®. Aplicación a pared. **(Fijaciones no incluydas - pag. 156)**

Panel mit Polyester-Füllmaterial von **unterschiedlicher Dichte**. Polyester-Bezug aus Trevira CS®-Material. Wandanwendung. **(Befestigungen nicht inkludiert - Seite 156)**.

59 cm

7SP0606/2-0001 Bianco
White
Blanc
Blanco
Weiß



59 cm

Supergattomaggiore 1967

Pannello con imbottitura interna in poliester a **densità variabile**. Rivestimento esterno in tessuto di poliester Trevira CS®. Applicabile a parete. **(Attacchi non inclusi - vedi pag. 156)**.

Panel with internal padding in **variable density** polyester. Outer cover in Trevira CS® polyester fabric. Wall mounting. **(Fixings not included - see page 156)**.

Panneau avec rembourrage interne en polyester à **densité variable**. Revêtement externe en tissu de polyester Trevira CS®. Application au mur. **(Fixations pas inclus - voir page 156)**.

Panel con acolchado interior de poliéster de **densidad variable**. Revestimiento exterior de tejido de poliéster Trevira CS®. Aplicación a pared. **(Fijaciones no incluydas - pag. 156)**

Panel mit Polyester-Füllmaterial von **unterschiedlicher Dichte**. Polyester-Bezug aus Trevira CS®-Material. Wandanwendung. **(Befestigungen nicht inkludiert - Seite 156)**.

59 cm

7SP0806/1-0001 Bianco
White
Blanc
Blanco
Weiß



75 cm

Lettere disegnate / Drawn letters

Pannello con imbottitura interna in poliester a **densità variabile**. Rivestimento esterno in tessuto di poliester Trevira CS®. Applicabile a parete. **(Attacchi non inclusi - vedi pag. 156)**.

Panel with internal padding in **variable density** polyester. Outer cover in Trevira CS® polyester fabric. Wall mounting. **(Fixings not included - see page 156)**.

Panneau avec rembourrage interne en polyester à **densité variable**. Revêtement externe en tissu de polyester Trevira CS®. Application au mur. **(Fixations pas inclus - voir page 156)**.

Panel con acolchado interior de poliéster de **densidad variable**. Revestimiento exterior de tejido de poliéster Trevira CS®. Aplicación a pared. **(Fijaciones no incluydas - pag. 156)**

Panel mit Polyester-Füllmaterial von **unterschiedlicher Dichte**. Polyester-Bezug aus Trevira CS®-Material. Wandanwendung. **(Befestigungen nicht inkludiert - Seite 156)**.

59 cm

7SP1606/1-0001 Bianco
White
Blanc
Blanco
Weiß



159 cm

Porte dipinte / Painted doors 1957

Pannello con imbottitura interna in poliester a **densità variabile**. Rivestimento esterno in tessuto di poliester Trevira CS®. Applicabile a parete. **(Attacchi non inclusi - vedi pag. 156)**.

Panel with internal padding in **variable density** polyester. Outer cover in Trevira CS® polyester fabric. Wall mounting. **(Fixings not included - see page 156)**.

Panneau avec rembourrage interne en polyester à **densité variable**. Revêtement externe en tissu de polyester Trevira CS®. Application au mur. **(Fixations pas inclus - voir page 156)**.

Panel con acolchado interior de poliéster de **densidad variable**. Revestimiento exterior de tejido de poliéster Trevira CS®. Aplicación a pared. **(Fijaciones no incluydas - pag. 156)**

Panel mit Polyester-Füllmaterial von **unterschiedlicher Dichte**. Polyester-Bezug aus Trevira CS®-Material. Wandanwendung. **(Befestigungen nicht inkludiert - Seite 156)**.

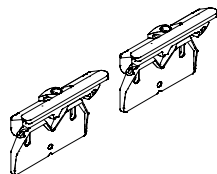

7S370-BO
Bianco opaco
Mat white
Blanc mat
Blanco mate
Mattweiß

1 coppia / 1 pair
1 paire / 1 pare
1 Paar

Coppia attacchi a parete in zama verniciata o nichel satinata.
Per il fissaggio a parete, è necessaria 1 coppia di attacchi per ogni pannello Snowsound Art cod. 7SP1206/1-0001 e 7SP1216/1-0001.
E' necessario 1 solo attacco per i codici: 7SP0606/1-0001 - 7SP0606/2-0001 - 7SP0806/1-0001 - 7SP1606/1-0001

Pair of wall fixings in zamac, painted or nickel satined.
For wall mounting, a set of two fixings is required for each Snowsound Art panel for codes 7SP1206/1-0001 e 7SP1216/1-0001.



7S370-C
Nichel satinato
Nickel satined
Nickel satinée
Niquel satinado
Nickel satiniert

1 coppia / 1 pair
1 paire / 1 pare
1 Paar

Only 1 pcs is required for codes 7SP0606/1-0001 - 7SP0606/2-0001 - 7SP0806/1-0001 - 7SP1606/1-0001

Paire de fixations murales en zamac peinte ou nickel satinée. Pour la fixation au mur il faut 1 paire de joints pour chaque panneau Snowsound Art pour réf. 7SP1206/1-0001 e 7SP1216/1-0001.

Il faut seulement 1 joint pour réf. 7SP0606/1-0001 - 7SP0606/2-0001 - 7SP0806/1-0001 - 7SP1606/1-0001.

Set de fijaciones a pared en zamac, pintado o niquel satinado. Para montaje a pared, se necesita un set de 2 pzs para cada panel Snowsound Art para cod. 7SP1206/1-0001 e 7SP1216/1-0001.

Se necesita solo 1 pieza para cod. 7SP0606/1-0001 - 7SP0606/2-0001 - 7SP0806/1-0001 - 7SP1606/1-0001

1 Paar Wandbefestigungen aus Zamac, lackiert oder Nickel satiniert. Für die Wandmontage wird ein Paar Befestigungen für jedes Snowsound Art Paneel benötigt Art. 7SP1206/1-0001 e 7SP1216/1-0001.

Eine befestigung für Art. 7SP0606/1-0001 - 7SP0606/2-0001 - 7SP0806/1-0001 - 7SP1606/1-0001

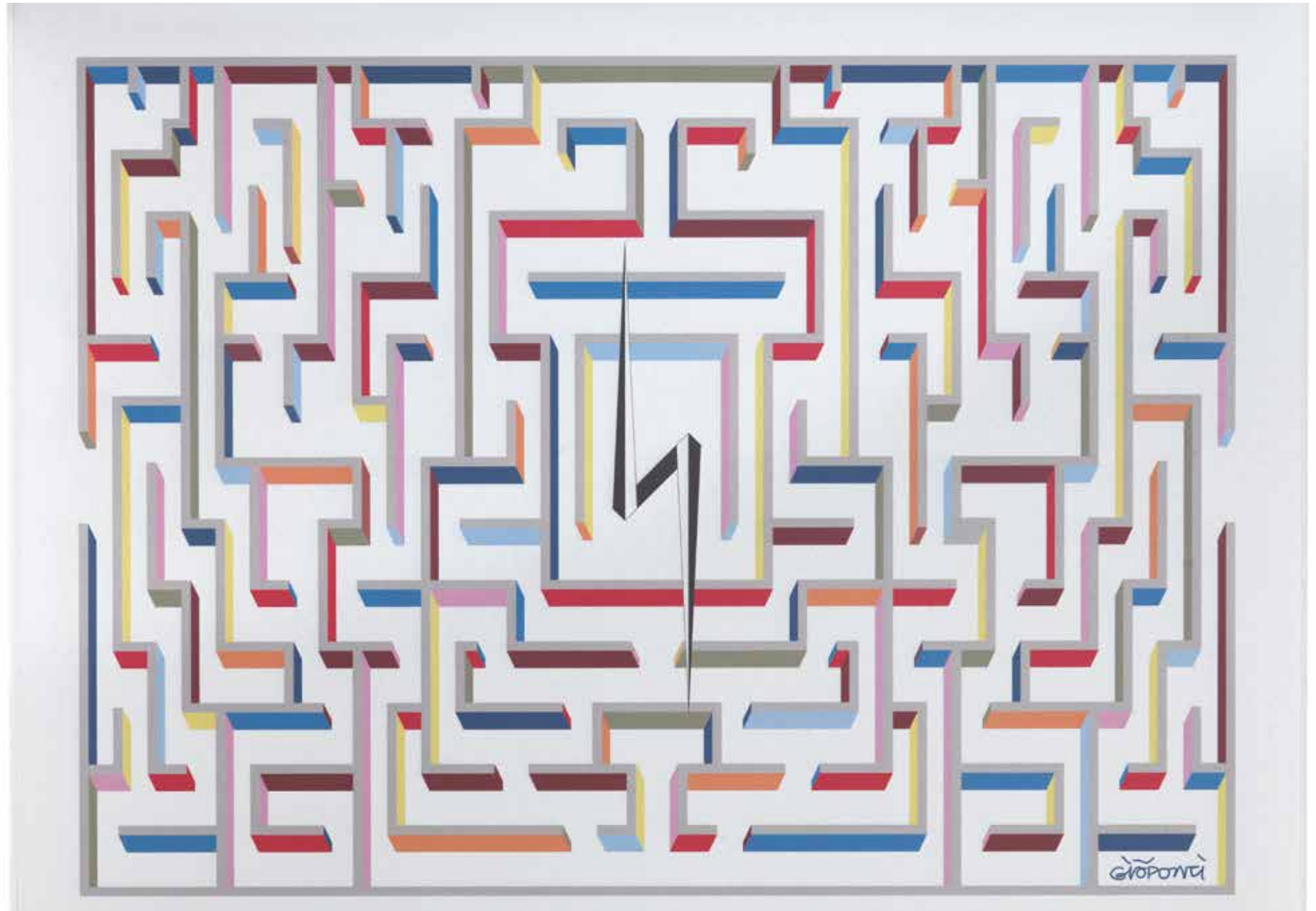



Lines 2019

Bianco
White
Blanc
Blanco
Weiß



Supporto nero
micaceo
Micaceous black
fixing

7GOWS/RNM-0001



Supporto cromato
Chrome-plated
fixing

7GOWS/RC-0001

Pannelli con imbottitura interna in poliester a **densità variabile**. Rivestimento esterno in tessuto di poliester Trevira CS®. Completi di supporto di fissaggio a parete in acciaio cromato o nero micaceo.

Panel with internal padding in **variable density** polyester. Outer cover in Trevira CS® polyester fabric. Complete with wall mounting bracket in chrome-plated steel or black micaceous finish.

Panneau avec rembourrage interne en polyester à **densité variable**. Revêtement externe en tissu de polyester Trevira CS®. Fourni avec support pour fixation murale en acier chromé ou noir micacé.

Panel con acolchado interior de poliéster de **densidad variable**. Revestimiento exterior en tejido de poliéster Trevira CS®. Se completa con un soporte de fijación mural de acero cromado o negro mica.

Panel mit Polyester-Füllmaterial von **unterschiedlicher Dichte**. Polyester-Bezug aus Trevira CS®-Material. Inklusive Wandhalterung aus verchromtem oder schwarz schimmerndem Stahl.

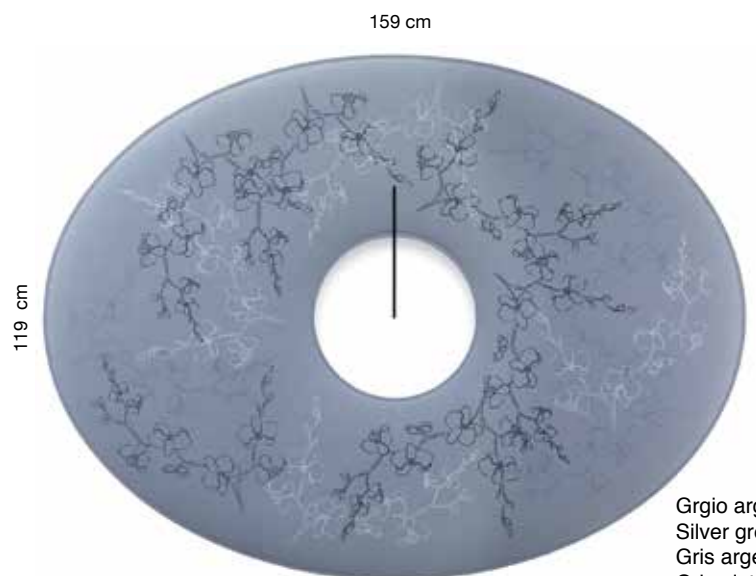

Nature 2019

Grgio argento
Silver grey
Gris argenté
Gris plata
Silbergrau



Supporto nero
micaceo
Micaceous black
fixing

7GOWS/FNM-8004



Supporto cromato
Chrome-plated
fixing

7GOWS/FC-8004

Pannelli con imbottitura interna in poliester a **densità variabile**. Rivestimento esterno in tessuto di poliester Trevira CS®. Completi di supporto di fissaggio a parete in acciaio cromato o nero micaceo.

Panel with internal padding in **variable density** polyester. Outer cover in Trevira CS® polyester fabric. Complete with wall mounting bracket in chrome-plated steel or black micaceous finish.

Panneau avec rembourrage interne en polyester à **densité variable**. Revêtement externe en tissu de polyester Trevira CS®. Fourni avec support pour fixation murale en acier chromé ou noir micacé.

Panel con acolchado interior de poliéster de **densidad variable**. Revestimiento exterior en tejido de poliéster Trevira CS®. Se completa con un soporte de fijación mural de acero cromado o negro mica.

Panel mit Polyester-Füllmaterial von **unterschiedlicher Dichte**. Polyester-Bezug aus Trevira CS®-Material. Inklusive Wandhalterung aus verchromtem oder schwarz schimmerndem Stahl.

ø 119 cm

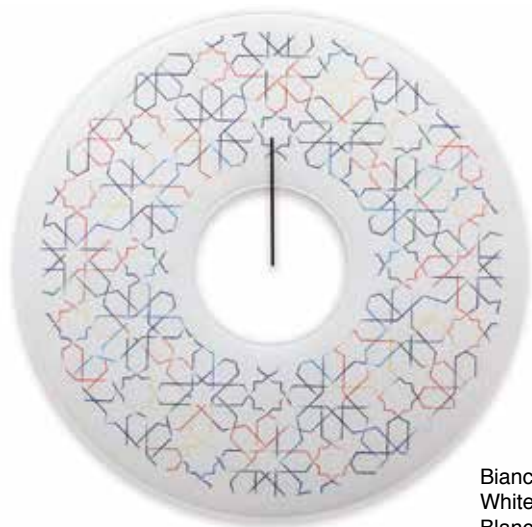

Bianco
White
Blanc
Blanco
Weiß



Supporto nero
micaceo
Micaceous black
fixing

7GWS/CNM-0001



Supporto cromato
Chrome-plated
fixing

7GWS/CC-0001

Pannelli con imbottitura interna in poliester a **densità variabile**. Rivestimento esterno in tessuto di poliester Trevira CS®. Completi di supporto di fissaggio a parete in acciaio cromato o nero micaceo.

Panel with internal padding in **variable density** polyester. Outer cover in Trevira CS® polyester fabric. Complete with wall mounting bracket in chrome-plated steel or black micaceous finish.

Panneau avec rembourrage interne en polyester à **densité variable**. Revêtement externe en tissu de polyester Trevira CS®. Fourni avec support pour fixation murale en acier chromé ou noir micacé.

Panel con acolchado interior de poliéster de **densidad variable**. Revestimiento exterior en tejido de poliéster Trevira CS®. Se completa con un soporte de fijación mural de acero cromado o negro mica.

Panel mit Polyester-Füllmaterial von **unterschiedlicher Dichte**. Polyester-Bezug aus Trevira CS®-Material. Inklusive Wandhalterung aus verchromtem oder schwarz schimmerndem Stahl.

Ottoman 2019



7SM6-C

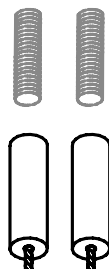

Per M6 (non inclusa)
For M6 (not included)

1 coppia / 1 pair
1 paire / 1 pare
1 Paar

OPZIONALE / OPTIONAL

Coppia attacchi per viti M6. Utilizzabile per tutte le applicazioni a soffitto. Può sostituire la piastra a due fori fornita con i pannelli (dove prevista)

Pair of connections for M6 screws. Can be used for all ceiling applications. Can replace the two holes plate supplied with the panels (where applicable)

Paire de raccords pour vis M6. Peut être utilisé pour toutes les applications au plafond. Peut remplacer la platine à deux trous fournie avec les panneaux (le cas échéant)

Par de conexiones para tornillos M6. Se puede utilizar para todas las aplicaciones de techo. Puede sustituir la placa con dos huecos suministrada con los paneles (si procede)

Paar von Befestigungen für M6 Schrauben. Für alle Deckenarten geeignet. Kann an Stelle der mitgelieferten Montageplatte mit zwei Lochungen verwendet werden.

7SL/RD7-BO



OPZIONALE / OPTIONAL

Rosone per pannelli:
Ceiling rose for panels:
Rosace pour panneaux:
Rosetón para paneles:
Rosette für paneele:

OVERSIZE LUX
7OL1212/1F-XXXX / 7OL1216/2F-XXXX / 7OL1212/L6-XXXX /
7OL1212/D6-XXXX / 7OL1216/L9-XXXX / 7OL1216/D9-XXXX /
7OL1206/L6-XXXX / 7OL1206/D6-XXXX / 7OL1606/L9-XXXX /
7OL1606/D9-XXXX

GIOTTO LUX
7GL120-XXXX / 7GL120/D-XXXX / 7GOL-XXXX / 7GOL/D-XXXX

7SL/R2F-BO

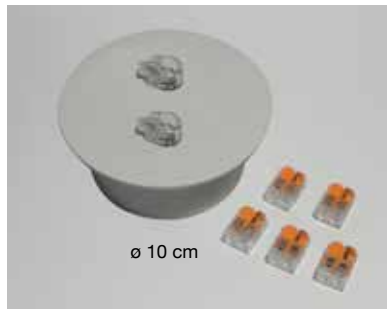

OPZIONALE / OPTIONAL

Rosone per pannelli:
Ceiling rose for panels:
Rosace pour panneaux:
Rosetón para paneles:
Rosette für paneele:

OVERSIZE LUX
7OL12/2L6-XXXX / 7OL12/2D6-XXXX / 7OL16/2L9-XXXX /
7OL16/2D9-XXXX

7SL/DML60

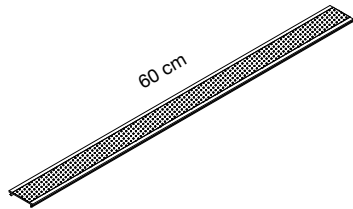

OPZIONALE / OPTIONAL

Diffusore microprismatico - UGR (indice unificato di abbagliamento) < 19. Norma UNI EN 12464-1:2011.

Microprismatic Diffuser - UGR (Unified Glare Rating) < 19. Standard UNI EN 12464-1:2011.

Diffuseur microprismatique - UGR (Unified Glare Rating) < 19. Norme UNI EN 12464-1:2011.

Difusor Microprismático - UGR (Unified Glare Rating) < 19. Norma UNI EN 12464-1:2011.

Microprismatischer Diffusor - UGR (Unified Glare Rating) < 19. Norm UNI EN 12464-1:2011.

1 pezzo / 1 piece per pannelli / for panels

OVERSIZE LUX

7OL1212/L6-XXXX / 7OL1212/D6-XXXX / 7OL1206/L6-XXXX / 7OL1206/D6-XXXX /

2 pezzi / 2 pieces per pannelli / for panels

OVERSIZE LUX

7OL12/2L6-XXXX / 7OL12/2D6-XXXX

7SL/DML90

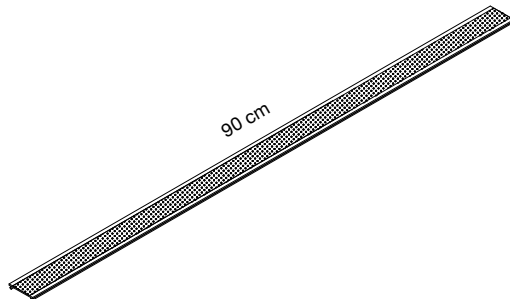

OPZIONALE / OPTIONAL

Diffusore microprismatico - UGR (indice unificato di abbagliamento) < 19. Norma UNI EN 12464-1:2011.

Microprismatic Diffuser - UGR (Unified Glare Rating) < 19. Standard UNI EN 12464-1:2011.

Diffuseur microprismatique - UGR (Unified Glare Rating) < 19. Norme UNI EN 12464-1:2011.

Difusor Microprismático - UGR (Unified Glare Rating) < 19. Norma UNI EN 12464-1:2011.

Microprismatischer Diffusor - UGR (Unified Glare Rating) < 19. Norm UNI EN 12464-1:2011.

1 pezzo / 1 piece per pannelli / for panels

OVERSIZE LUX

7OL1216/L9-XXXX / 7OL1216/D9-XXXX / 7OL1606/L9-XXXX / 7OL1606/D9-XXXX

2 pezzi / 2 pieces per pannelli / for panels

OVERSIZE LUX

7OL16/2L9-XXXX / 7OL16/2D9-XXXX

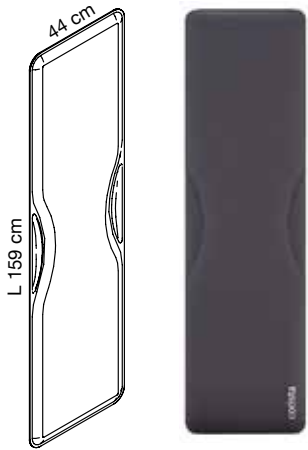
**7C164-8033**

Nero
Black
Noir

Pannello con imbottitura interna in poliester a **densità variabile** Snowsound® Technology e rivestimento esterno in tessuto di poliester Trevira CS®. Peso del singolo pannello 2,5 Kg.

Panel with polyester internal padding with Snowsound® Technology **variable density** and polyester covering in Trevira CS® fabric. Weight of the single panel: 2,5 kg

Panneau avec rembourrage interne en polyester à **densité variable** Snowsound® Technology et revêtement externe en tissu de polyester Trevira CS®. Poids d'un panneau: 2,5 kg

Panel con acolchado interior de poliéster de **densidad variable** Snowsound® Technology y revestimiento exterior de tejido de poliéster Trevira CS®. Peso para singolo panel 2,5 Kg

Panel mit Polyester-Füllmaterial von **unterschiedlicher Dichte** Snowsound® Technology und Polyester-Bezug aus Trevira CS®-Material. Gewicht eines Paneels: 2,5 kg.

Cavalletto in acciaio verniciato con polveri epossidiche per 1 pannello Corista o Mitesco.

Epoxy powder-coated steel stand for one Corista or Mitesco panel.

Chevalet en acier peint époxy pour 1 panneau Corista ou Mitesco.

Soporte de acero recubierto epoxi para 1 panel Corista o Mitesco.

Standfuß aus pulverbeschichtetem Stahl für ein Corista oder Mitesco Paneel

7C510/1-N

Nero
Black
Noir
Negro
Schwarz

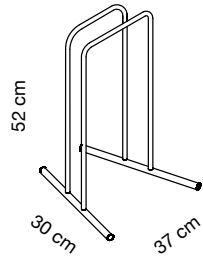
**7C164-BORSA**

Borsa per pannelli Corista e Mitesco. Può contenere fino a 4 pannelli lunghezza 159 cm.

Carry bag for Corista and Mitesco panels. Contains up to four panels 159 cm long.

Sac pour panneaux Corista et Mitesco. Il peut contenir un maximum de 4 panneaux L.159 cm.

Bolsa para paneles Corista o Mitesco. Puede contener hasta 4 paneles L.159 cm.

Tragtasche für Corista und Mitesco Paneele, für bis zu 4 Paneele mit 159 cm Länge



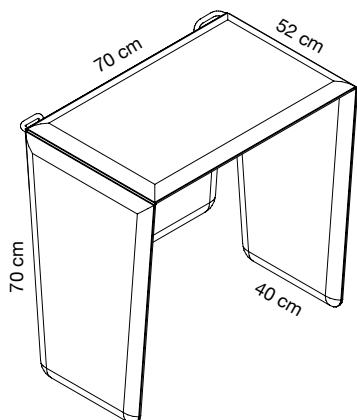

7CK700-8004

Grigio argento
Silver grey
Gris argenté

7CK700-4027

Rosso
Red
Rouge

7CK700-7013

Verde
Green
Vert

Phone boot con struttura in tondino di acciaio verniciato e copertura composta da imbottitura interna in poliester e rivestimento esterno in tessuto di poliester Trevira CS®, completamente sfoderabile.

Phone booth with powder-coated steel rod structure, cover composed by polyester internal padding and polyester Trevira CS® fabric external coating, totally removable.

Cabine avec structure en tiges d'acier peint epoxy et couverture avec rembourrage interne en polyester et revêtement externe en tissu de polyester Trevira CS® entièrement amovible.

Phone Boot con estructura de hilo de acero recubierto y cobertura compuesta para acolchado interior en poliester y revestimiento exterior de tejido de poliester Trevira CS®, totalmente amovible.

Telefonzelle mit Gestell aus beschichtetem Stahlrohr zur Wandmontage, Abdeckung bestehend aus einer Polyester-Polsterung und einem komplett abziehbaren Bezug aus Polyesterstoff Trevira CS®

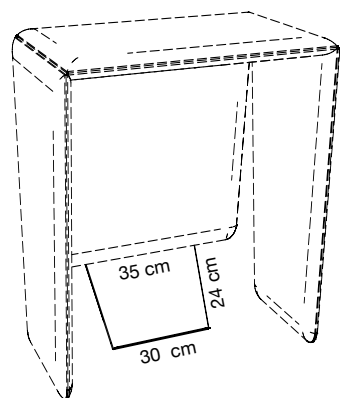

7CK500-GA

Grigio argento
Silver grey
Gris argenté
Gris plata
Silbergrau

Piano in acciaio verniciato per con polveri epossidiche per phone boot Cocker.

Powder-coated steel shelf for phone boot Cocker.

Tablette en acier peint epoxy pour cabine Cocker

Estante en acero recubierto para phone boot Cocker

Beschichtetes Regalboden für Telefonzelle Cocker



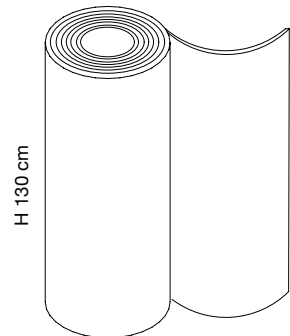

H 130 cm

L. 600 cm

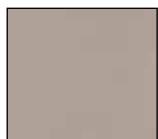
1 Rotolo = 7,8 m²Colore
ColourBianco
White
Blanc
Weiss
BlancoGrigio argento
Silver grey
Gris argenté
Gris plata
SilbergrauBeige
Beige
Beige
Beige
BeigeVerde
Green
Vert
Verde
GrünerRosso
Red
Rouge
Rojo
RotCodice/Code
Prezzo/Price**7SW6-0001****7SW6-8004****7SW6-1008****7SW6-7013****7SW6-4027**

Rotolo di feltro in Poliestere rivestito in tessuto di poliestere Trevira CS®.

Roll of polyester felt coated with Trevira CS® polyester fabric.

Rouleau de feutre en Polyester recouvert en tissu de polyester Trevira CS®.

Rollo de fieltro de poliéster tapizado con tejido de poliéster Trevira CS®.

Rolle von Polyester-Filz, bezogen mit Trevira CS® Polyesterstoff.

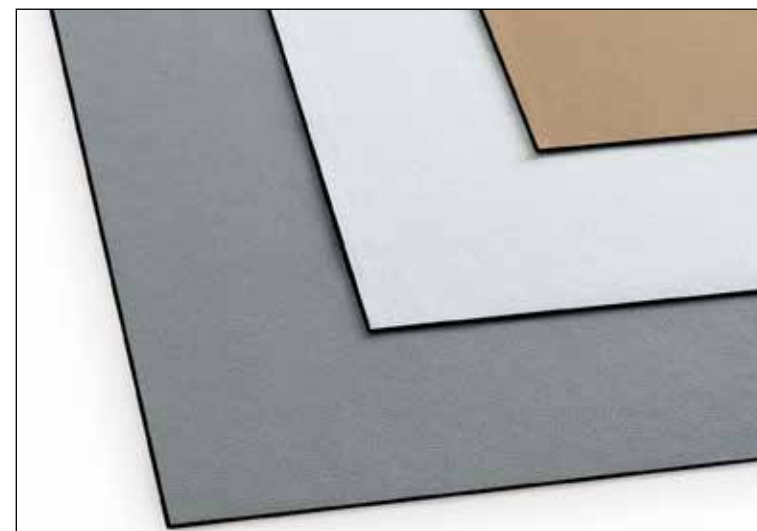



Colore
ColourCodice/Code
Prezzo/Price

Struttura in acciaio e poliestere, rivestimento in tessuto fonoassorbente **Snowsound-Fiber Textiles 1 Color**. Tessuto asportabile e lavabile.

Steel and polyester frame, cover in **Snowsound-Fiber Textiles 1 Color** sound-absorbing fabric. Removable and washable fabric.

Structure en acier et polyester, revêtement en textile phono-absorbant **Snowsound-Fiber Textiles 1 Color**. Tissu amovible et lavable.

Estructura de acero y poliéster, cubierta de tejido fonoabsorbente **Snowsound-Fiber Textiles 1 Color**. Tejido extraíble y lavable.

Struktur aus Stahl und Polyester, Bezug aus **Snowsound-Fiber Textiles 1 Color** schallabsorbierendem Gewebe. Stoff abnehmbar und waschbar.

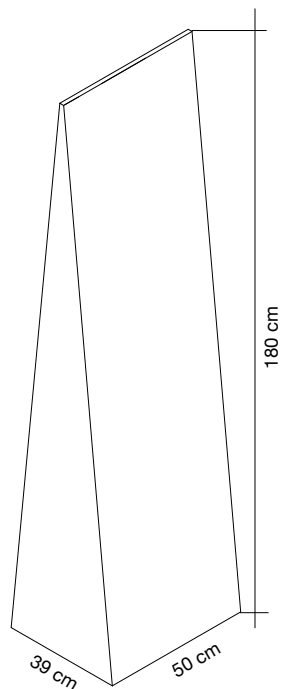
**7OP185-0001****FIBER 1 col. 0001**

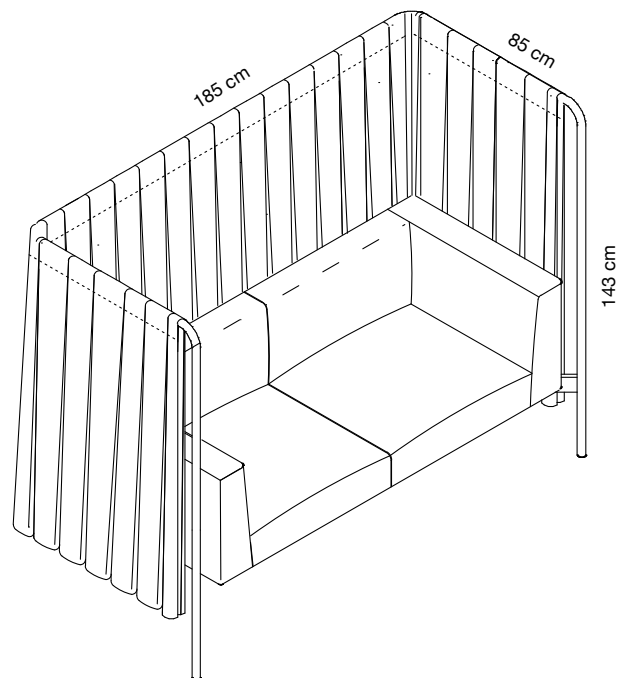

Snowsound-Fiber 33 m²Fatto a mano
Handmade

Tempi di consegna 4/6 settimane (mese di agosto escluso)

Lead time 4/6 weeks (month of August excluded)

Délai d'expédition 4/6 semaines (sauf le mois d'Août)

Tiempos de entrega 4/6 semanas (mes de Agosto no incluido)

Lieferzeit 4/6 Wochen (ausgenommen August)

Tutti i colori **Fiber 3 Melange e Fiber 6 Velvet** riportati rispettivamente a pag. 197 e a pag. 199 del presente listino sono disponibili su richiestaAll the colours **Fiber 3 Melange and Fiber 6 Velvet** shown on page 197 and on page 199 of this price list are available on request.Toutes les couleurs **Fiber 3 Melange et Fiber 6 Velvet** représentées à la page 197 et à la page 199 de cette liste de prix sont disponibles sur demande.Todos los colores **Fiber 3 Melange y Fiber 6 Velvet** mostrados en la página 197 y en la página 199 de esta lista de precios están disponibles bajo petición.Alle Farben **Fiber 3 Melange und Fiber 6 Velvet** auf Seite 197 und Seite 199 dieser Preisliste sind auf Anfrage erhältlich.Colore
ColourCodice/Code
Prezzo/Price**FIBER 3**
Vedi pag. 171
See page 171

7SO2P-300



7SO2P-303



7SO2P-305

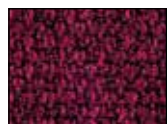

7SO2P-306



7SO2P-309

Colore
ColourCodice/Code
Prezzo/Price**FIBER 6**
Vedi pag. 170
See page 170

7SO2P-600



7SO2P-603



7SO2P-605



7SO2P-606



7SO2P-610

Divano acustico a schienale alto realizzato con tessuti in poliester

Snowsound-Fiber 6 Velvet e Fiber 3 Melange
Struttura in tubolare d'acciaio verniciato nero. Fusto in legno multi-strato e massello, con imbottitura in poliuretano espanso, densità 30 e 40 Kg/m³. **Completamente sfoderabile.**

Il divano è chiuso sui tre lati da pannello in tessuto Snowsound-Fiber 6 Velvet o Fiber 3 Melange arricciato a 6 strati.

Acoustic high back sofa made of **Snowsound-Fiber 6 Velvet and Fiber 3 Melange** polyester fabric.Frame in black epoxy-powder coated tubular steel. Multilayer solid wood frame with polyurethane foam padding, density 30 and 40 Kg/m³. **Fully removable cover.**

The sofa is closed on three sides by draping Snowsound-Fiber 6 Velvet or Fiber 3 Melange fabric curled with 6 layers.

Divan acoustique avec dossier haut réalisé avec tissus en polyester

Snowsound-Fiber 6 Velvet et Fiber 3 Melange. Structure en tube d'acier peint noir. Fût en bois feuilleté et massif, avec rembourrage en expansé, densité 30 et 40 Kg/m³.**Complètement dédoublable.**

Le divan est fermé sur trois côtés par un drap en tissu Snowsound-Fiber 6 Velvet ou Fiber 3 Melange froncé à 6 couches.

Sofá acústico con respaldo alto que se realizó con tela de poliéster

Snowsound-Fiber 6 Velvet y Fiber 3 Melange. Marco de acero tubular barnizado negro. Esqueleto de madera multicapa y maciza, con acolchado de espuma rígida de poliuretano, densidad 30 y 40 Kg/m³. **Completamente desenfundable.**

Los tres costados del sofá están drapados con tela Snowsound-Fiber 6 Velvet o Fiber 3 Melange fruncida de 6 capas.

Schalldämpf-Sofa mit hoher Lehne, aus Polyesterfaser **Snowsound-Fiber 6 Velvet und Fiber 3 Melange** hergestellt. Schwarz lackiertes Stahlrohr-Gerüst. Gestell aus massivem und Mehrschichtholz, Polsterung aus Polyurethan-Hartschaum, Dichte 30 und 40 Kg/m³. **Komplett ausziehbar.**

Das Sofa ist auf drei Seiten mit 6-lagig zusammengefaltetem Gewebe Snowsound-Fiber 6 Velvet oder Fiber 3 Melange umrahmt.



SNOWSOUND FIBER

COLORI TESSUTI - TEXTILES' COLORS - COULEURS TISSUS -
COLORES DE TELAS - STOFFFARBEN

605



FIBER 6 VELVET

606



FIBER 6 VELVET

610



FIBER 6 VELVET

603



FIBER 6 VELVET

600



FIBER 6 VELVET

SNOWSOUND FIBER

COLORI TESSUTI - TEXTILES' COLORS - COULEURS TISSUS -
COLORES DE TELAS - STOFFFARBEN

300

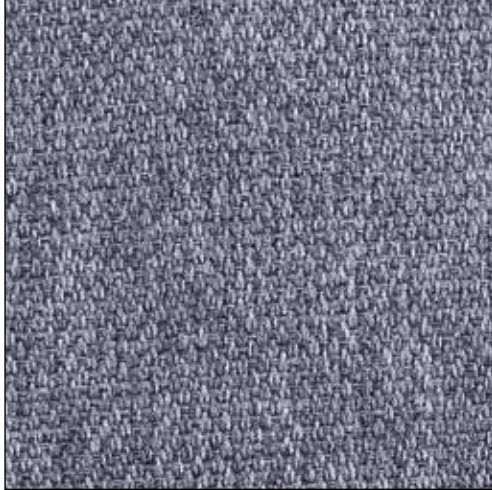

FIBER 3 MELANGE

303

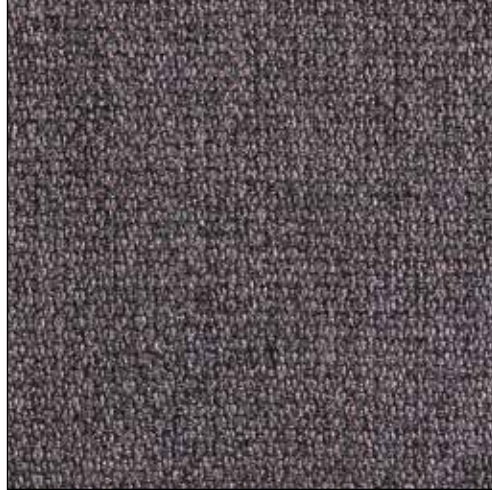

FIBER 3 MELANGE

305



FIBER 3 MELANGE

306



FIBER 3 MELANGE

309



FIBER 3 MELANGE

310

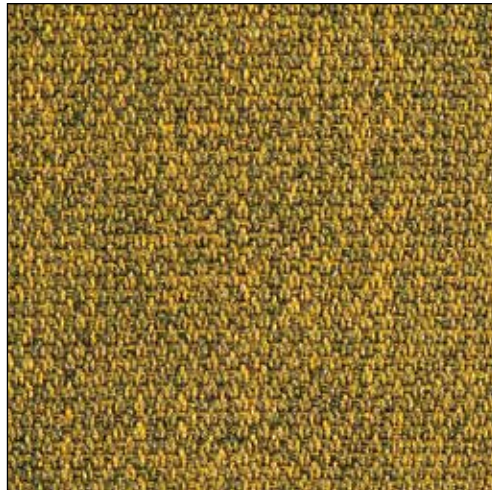

FIBER 3 MELANGE

CLASP CEILING

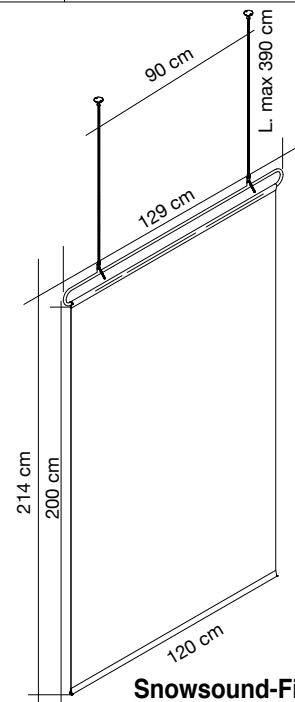

Snowsound-Fiber 2,4 m²

Colore **FIBER 3**
Colour **Vedi pag. 171**
See page 171

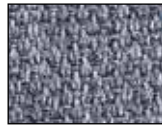

7CLC200/CL-300



7CLC200/CL-305



7CLC200/CL-306



7CLC200/CL-310

Codice/Code
Prezzo/Price

Telo fonoassorbente in poliestere **Snowsound-Fiber Textiles 3 Melange**. Telaio in acciaio cromato, 2 piastre a soffitto a 2 fori - 2 cavi in acciaio. Barra di irrigidimento inferiore. Tessuto asportabile e lavabile.

Snowsound-Fiber Textiles 3 Melange sound absorbing fabric. Chrome-plated steel frame, 2 ceiling plates with 2 holes - 2 steel cables. Lower stiffening bar. Removable and washable fabric.

Toile phono-absorbante **Snowsound-Fiber Textiles 3 Melange**. Structure en acier chromé, 2 plaques de plafond avec 2 trous - 2 câbles en acier. Barre de raidissement inférieure. Tissu amovible et lavable.

Tejido fonoabsorbente **Snowsound-Fiber Textiles 3 Melange**. Bastidor de acero cromado, 2 placas de techo con 2 agujeros - 2 cables de acero. Barra de refuerzo inferior. Tejido extraíble y lavable.

Snowsound-Fiber Textiles 3 Melange schallabsorbierendes Gewebe. Verchromter Stahlrahmen mit 2 Stahlseilen samt Deckenplatten mit 2 Montagebohrungen. Stabilisierungsleiste im unteren Ende der Stoffbahn. Stoff abnehmbar und waschbar.

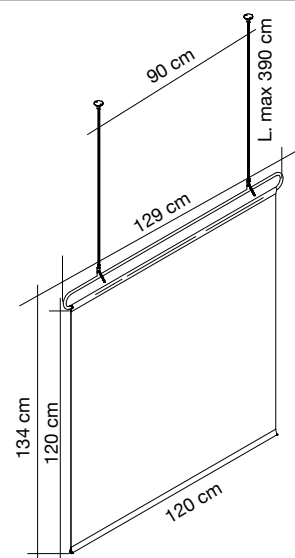

Snowsound-Fiber 1,44 m²

Colore **FIBER 3**
Colour **Vedi pag. 171**
See page 171



7CLC120/CL-300



7CLC120/CL-305



7CLC120/CL-306



7CLC120/CL-310

Codice/Code
Prezzo/Price

Telo fonoassorbente in poliestere **Snowsound-Fiber Textiles 3 Melange**. Telaio in acciaio cromato, 2 piastre a soffitto a 2 fori - 2 cavi in acciaio. Barra di irrigidimento inferiore. Tessuto asportabile e lavabile.

Snowsound-Fiber Textiles 3 Melange sound absorbing fabric. Chrome-plated steel frame, 2 ceiling plates with 2 holes - 2 steel cables. Lower stiffening bar. Removable and washable fabric.

Toile phono-absorbante **Snowsound-Fiber Textiles 3 Melange**. Structure en acier chromé, 2 plaques de plafond avec 2 trous - 2 câbles en acier. Barre de raidissement inférieure. Tissu amovible et lavable.

Tejido fonoabsorbente **Snowsound-Fiber Textiles 3 Melange**. Bastidor de acero cromado, 2 placas de techo con 2 agujeros - 2 cables de acero. Barra de refuerzo inferior. Tejido extraíble y lavable.

Snowsound-Fiber Textiles 3 Melange schallabsorbierendes Gewebe. Verchromter Stahlrahmen mit 2 Stahlseilen samt Deckenplatten mit 2 Montagebohrungen. Stabilisierungsleiste im unteren Ende der Stoffbahn. Stoff abnehmbar und waschbar.



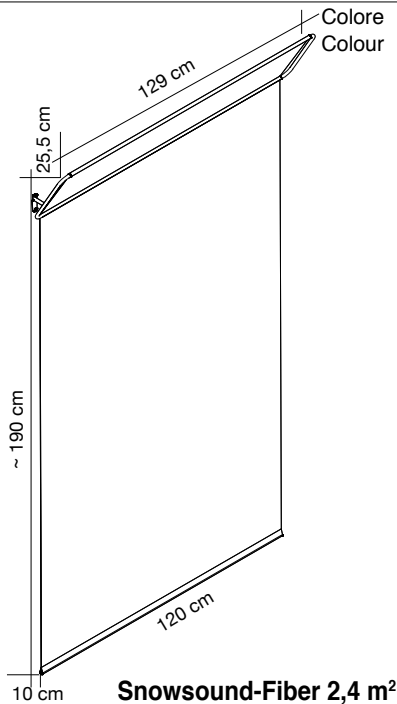

Colore
Colour

FIBER 3
Vedi pag. 171
See page 171

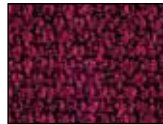
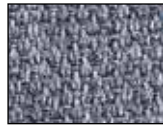

Codice/Code
Prezzo/Price

Telo fonoassorbente (200x120 cm) in poliesteri **Snowsound-Fiber Textiles 3 Melange**. Telaio per fissaggio a parete in acciaio cromato. Barra di irrigidimento inferiore. Tessuto asportabile e lavabile.

7CLW200/CL-300

Snowsound-Fiber Textiles 3 Melange sound absorbing fabric (200x120 cm). Chrome-plated steel wall mounting frame. Lower stiffening bar. Removable and washable fabric.

7CLW200/CL-305

Toile phono-absorbante (200x120 cm) **Snowsound-Fiber Textiles 3 Melange**. Cadre de montage mural en acier chromé. Barre de raidissement inférieure. Tissu amovible et lavable.

7CLW200/CL-306

Tejido fonoabsorbente (200x120 cm) **Snowsound-Fiber Textiles 3 Melange**. Bastidor de montaje en pared de acero cromado. Barra de refuerzo inferior. Tejido extraible y lavable.

7CLW200/CL-310

Snowsound-Fiber Textiles 3 Melange schallabsorbierendes Gewebe (200x120 cm). Verchromter Wandstahlrahmen mit 2 Stahlseilen samt Deckenplatten mit 2 Montagebohrungen. Stabilisierungsleiste im unteren Ende der Stoffbahn. Stoff abnehmbar und waschbar.

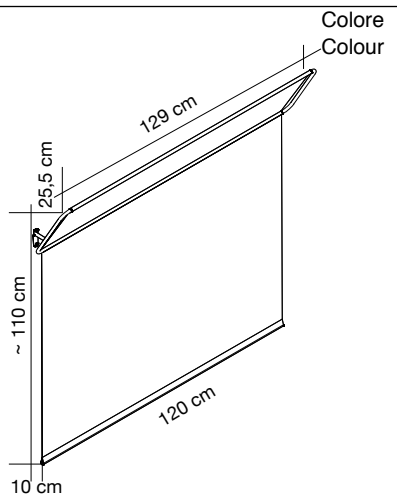

Colore
Colour

FIBER 3
Vedi pag. 171
See page 171

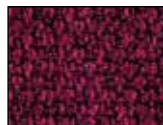

Codice/Code
Prezzo/Price

Telo fonoassorbente (120x120 cm) in poliesteri **Snowsound-Fiber Textiles 3 Melange**. Telaio per fissaggio a parete in acciaio cromato. Barra di irrigidimento inferiore. Tessuto asportabile e lavabile.

7CLW120/CL-300

Snowsound-Fiber Textiles 3 Melange sound absorbing fabric (120x120 cm). Chrome-plated steel wall mounting frame. Lower stiffening bar. Removable and washable fabric.

7CLW120/CL-305

Toile phono-absorbante (120x120 cm) **Snowsound-Fiber Textiles 3 Melange**. Cadre de montage mural en acier chromé. Barre de raidissement inférieure. Tissu amovible et lavable.

7CLW120/CL-306

Tejido fonoabsorbente (120x120 cm) **Snowsound-Fiber Textiles 3 Melange**. Bastidor de montaje en pared de acero cromado. Barra de refuerzo inferior. Tejido extraible y lavable.

7CLW120/CL-310

Snowsound-Fiber Textiles 3 Melange schallabsorbierendes Gewebe (120x120 cm). Verchromter Wandstahlrahmen mit 2 Stahlseilen samt Deckenplatten mit 2 Montagebohrungen. Stabilisierungsleiste im unteren Ende der Stoffbahn. Stoff abnehmbar und waschbar.



Snowsound-Fiber 1,44 m²

CLASP DIVIDER

design studio A+B Dominoni Quaquaro
Snowsound® Fiber by Caimi Brevetti

7CLD60-CL

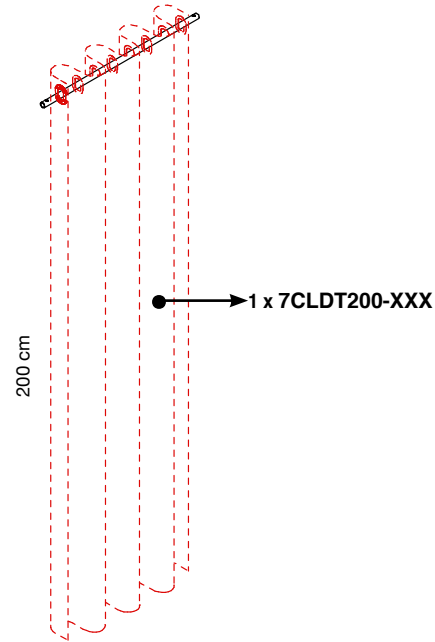
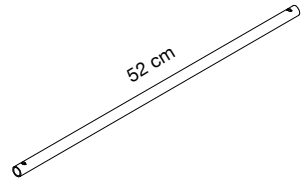

Asta in acciaio cromato L. 52 cm. Per 1 telo cod. 7CLDT200-XXX (XXX = variante colore)

Chrome-plated steel rod L. 52 cm. For 1 fabric cod. 7CLDT200-XXX (XXX = color variant)

Tige en acier chromé L. 52 cm. Pour 1 toile cod. 7CLDT200-XXX (XXX = variante couleur)

Barra de acero cromado L. 52 cm. Para 1 tejido cód. 7CLDT200-XXX (XXX = variante de color)

Stange aus verchromtem Stahl L. 52 cm. Für 1 Stoffbahn Art.Nr. 7CLDT200-XXX (XXX = Farbvariante)

7CLD120-CL

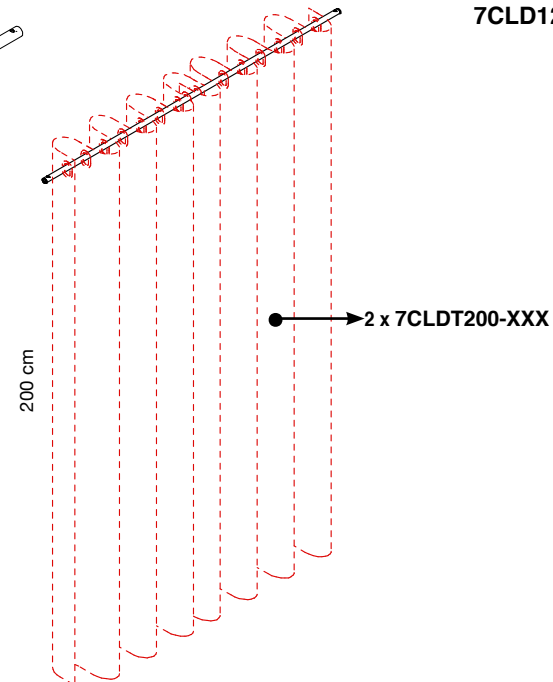
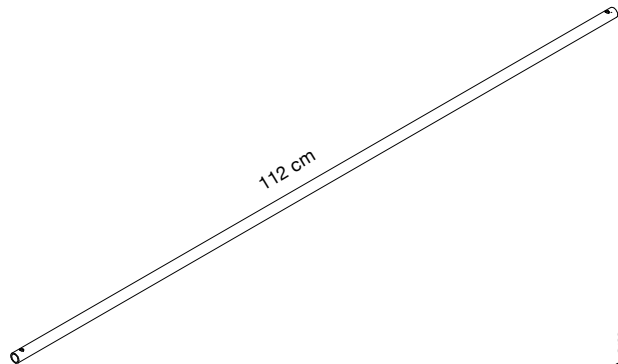

Asta in acciaio cromato L. 112 cm. Per 2 teli cod. 7CLDT200-XXX (XXX = variante colore)

Chrome-plated steel rod L. 112 cm. For 2 fabrics cod. 7CLDT200-XXX (XXX = color variant)

Tige en acier chromé L. 112 cm. Pour 2 toiles cod. 7CLDT200-XXX (XXX = variante couleur)

Barra de acero cromado L. 112 cm. Para 2 tejidos cód. 7CLDT200-XXX (XXX = variante de color)

Stange aus verchromtem Stahl L. 112 cm. Für 1 Stoffbahn Art.Nr. 7CLDT200-XXX (XXX = Farbvariante)

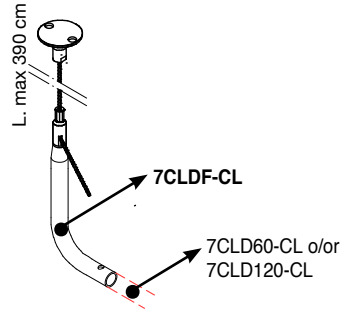

7CLDF-CL

Supporto terminale completo di cavo e piastra a soffitto a 2 fori. Da utilizzare per appendamento a soffitto delle aste cod. 7CLD60-CL e 7CLD120-CL. Consente di mantenere sempre il passo 60 o 120 cm

Terminal support complete with cable and 2-holes ceiling plate. To be used for ceiling hanging of rods code 7CLD60-CL and 7CLD120-CL. Allows you to always keep the 60 cm or 120 cm module.

Support d'extrémité complet avec câble et plaque de plafond à 2 trous. A utiliser pour l'accrochage au plafond des tiges code 7CLD60-CL et 7CLD120-CL. Permet de toujours garder un pas de 60 ou 120 cm

Soporte final completo con cable y placa de techo de 2 orificios. Para colgar en el techo las barras código 7CLD60-CL y 7CLD120-CL. Permite mantener siempre la inclinación de 60 o 120 cm.

Endstück komplett mit Stahlseil und Deckenplatte mit 2 Montagebohrungen. Zur Verwendung bei der Deckenmontage von Stangen Art. Nr. 7CLD60-CL und 7CLD120-CL. Erlaubt die Einhaltung der Teilung 60 oder 120 cm.

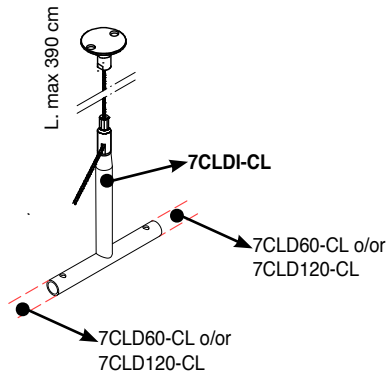

7CLDI-CL

Supporto centrale completo di cavo e piastra a soffitto a 2 fori. Da utilizzare per unione lineare e appendamento a soffitto delle aste cod. 7CLD60-CL e 7CLD120-CL. Consente di mantenere sempre il passo 60 o 120 cm

Central support complete with cable and 2-holes ceiling plate. To be used for linear connection and ceiling hanging of rods code 7CLD60-CL and 7CLD120-CL. Allows you to always keep the 60 cm or 120 cm module.

Support central complet avec câble et plaque de plafond à 2 trous. A utiliser pour le raccordement linéaire et l'accrochage au plafond des tiges code 7CLD60-CL et 7CLD120-CL. Permet de toujours garder un pas de 60 ou 120 cm

Soporte central completo con cable y placa de techo de 2 orificios. Se utiliza para la conexión lineal y la suspensión en el techo de las barras código 7CLD60-CL y 7CLD120-CL. Permite mantener siempre la inclinación de 60 o 120 cm.

Mittelstück komplett mit Stahlseil und Deckenplatte mit 2 Montagebohrungen. Zur Verwendung für die lineare Verbindung und Deckenabhängung von Stangen Art. Nr. 7CLD60-CL und 7CLD120-CL. Erlaubt die Einhaltung der Teilung 60 oder 120 cm.

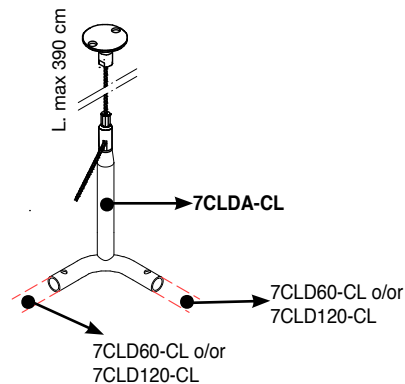

7CLDA-CL

Supporto angolare completo di cavo e piastra a soffitto a 2 fori. Da utilizzare per unione angolare e appendamento a soffitto delle aste cod. 7CLD60-CL e 7CLD120-CL. Consente di mantenere sempre il passo 60 o 120 cm

Corner support complete with cable and 2-holes ceiling plate. To be used for angular connection and ceiling hanging of rods code 7CLD60-CL and 7CLD120-CL. Allows you to always keep the 60 cm or 120 cm module.

Support d'angle complet avec câble et plaque de plafond à 2 trous. A utiliser pour le raccordement angulaire et l'accrochage au plafond des tiges code 7CLD60-CL et 7CLD120-CL. Permet de toujours garder un pas de 60 ou 120 cm

Soporte esquinero completo con cable y placa de techo de 2 orificios. Se utiliza para la conexión angular y la suspensión en el techo de las barras código 7CLD60-CL y 7CLD120-CL. Permite mantener siempre la inclinación de 60 o 120 cm.

Eckstück komplett mit Stahlseil und Deckenplatte mit 2 Montagebohrungen. Zur Verwendung für die Winkelverbindung und Deckenabhängung von Stangen Art. Nr. 7CLD60-CL und 7CLD120-CL. Erlaubt die Einhaltung der Teilung 60 oder 120 cm.

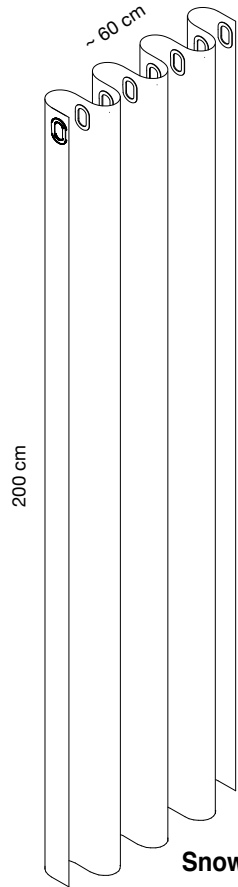
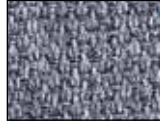
Snowsound-Fiber 2,8 m²Colore
Colour**FIBER 3****Vedi pag. 171****See page 171****7CLDT200-300****7CLDT200-305****7CLDT200-306****7CLDT200-310**Codice/Code
Prezzo/PriceTelo fonoassorbente (200x138 cm) in poliestere **Snowsound-Fiber Textiles 3 Melange**.

Per asta cod. 7CLD60-CL utilizzare 1 telo. Per asta cod. 7CLD120-CL utilizzare 2 teli

Snowsound-Fiber Textiles 3 Melange sound absorbing fabric (200x138 cm). For rod code 7CLD60-CL, use 1 fabric. For rod code 7CLD120-CL, use 2 fabrics.Toile phono-absorbante (200x138 cm) **Snowsound-Fiber Textiles 3 Melange**. Pour la tige code 7CLD60-CL, utiliser 1 toile. Pour la tige code 7CLD120-CL utiliser 2 toilesTejido fonoabsorbente (200x138 cm) **Snowsound-Fiber Textiles 3 Melange**. Para el código de barras 7CLD60-CL use 1 tejido. Para el código de barras 7CLD120-CL utilice 2 tejidos**Snowsound-Fiber Textiles 3 Melange** Stoffbahn aus schallabsorbierendem Gewebe (200x138 cm).

Für die Art. Nr. 7CLD60-CL verwenden Sie 1 Gewebbahn. Für die Art. Nr. 7CLD120-CL verwenden Sie 2 Gewebbahnen.

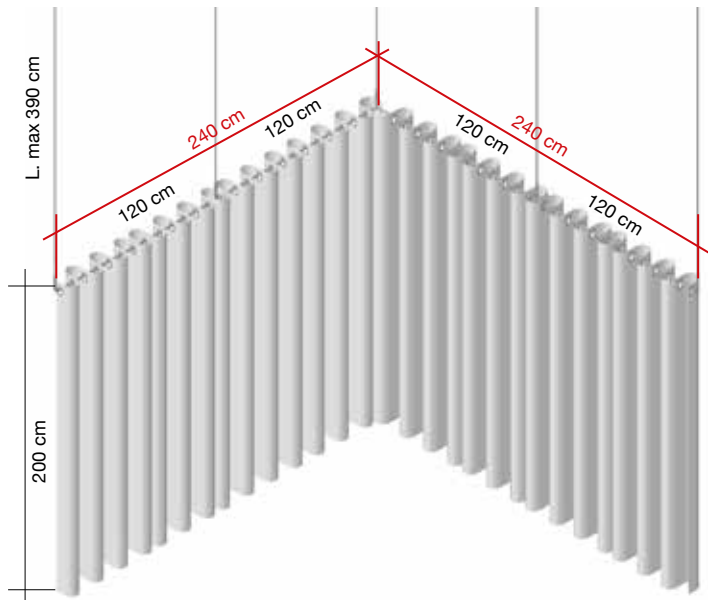

- 4 - 7CLD120-CL
- 2 - 7CLDF-CL
- 2 - 7CLDI-CL
- 1 - 7CLDA-CL
- 8 - 7CLDT200-XXX

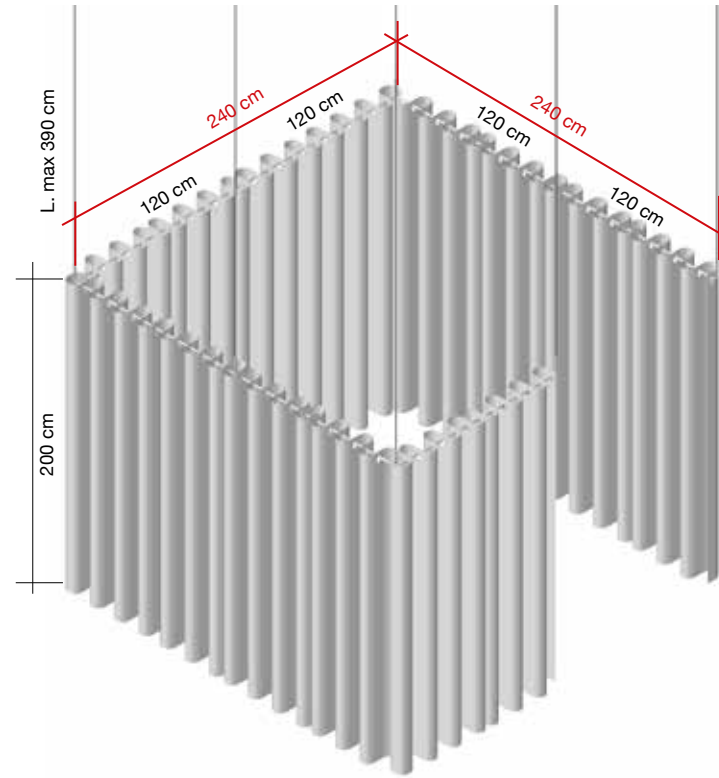

- 7 - 7CLD120-CL
- 2 - 7CLDF-CL
- 3 - 7CLDI-CL
- 3 - 7CLDA-CL
- 14 - 7CLDT200-XXX

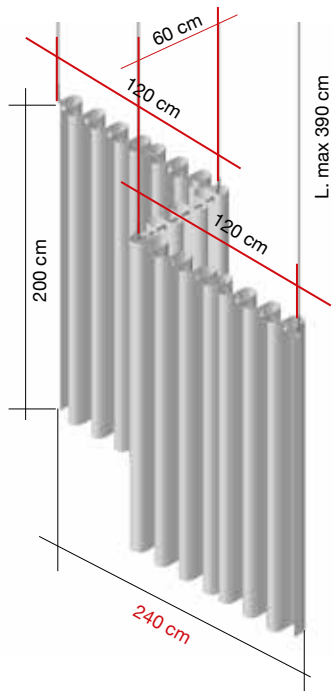

- 2 - 7CLD120-CL
- 1 - 7CLD60-CL
- 2 - 7CLDF-CL
- 2 - 7CLDA-CL
- 5 - 7CLDT200-XXX

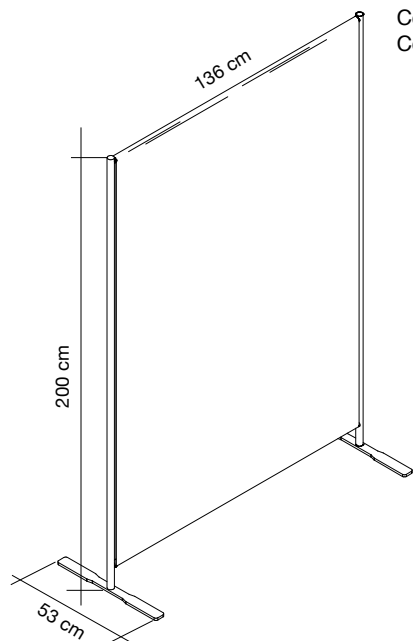

Snowsound-Fiber 4,9 m²

Colore
Colour

FIBER 3
Vedi / see p. 171

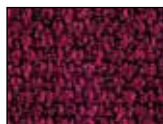

Codice/Code
Prezzo/Price

Divisorio con struttura in acciaio cromato e basi in acciaio verniciato, telo fonoassorbente in poliestere **Snowsound-Fiber Textiles 3 Melange**. Tessuto asportabile e lavabile.

7SEP/CL-300

Partition with chrome-plated steel frame and powder-coated steel bases, **Snowsound-Fiber Textiles 3 Melange** sound absorbing fabric. Removable and washable fabric.

7SEP/CL-305

Paravent avec structure en acier chromé et bases en acier peint epoxy, toile phono-absorbante **Snowsound-Fiber Textiles 3 Melange**. Tissu amovible et lavable.

7SEP/CL-306

Mampara de acero cromado con bases de acero barnizado, tejido fonoabsorbente **Snowsound-Fiber Textiles 3 Melange**. Tejido extraíble y lavable.

7SEP/CL-309

Trennwand mit Rahmen aus verchromtem Stahl, Standfüßen aus pulverbeschichtetem Stahl und Stoffbahn aus **Snowsound-Fiber Textiles 3 Melange** schallabsorbierendem Gewebe. Stoff abnehmbar und waschbar.

7SEP/CL-310



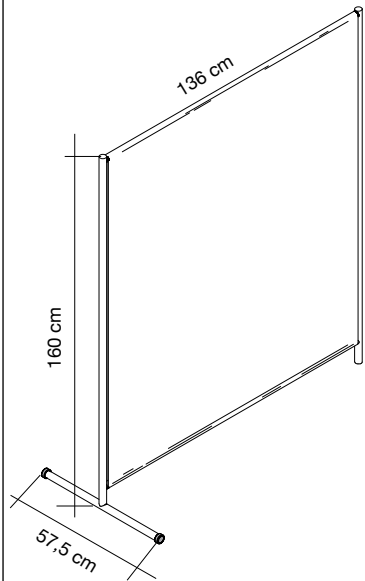

Snowsound-Fiber 3,9 m²

Colore **FIBER 3**
 Colour **Vedi / see p. 171**



Codice/Code
 Prezzo/Price

Divisorio con struttura in acciaio cromato con ruote, telo fonoassorbente in poliestere **Snowsound-Fiber Textiles 3 Melange**. Tessuto asportabile e lavabile.

7SEP/RCL-300

Partition with chrome-plated steel frame on castors, **Snowsound-Fiber Textiles 3 Melange** sound absorbing fabric. Removable and washable fabric.

7SEP/RCL-305

Cloison avec structure en acier chromé avec roulettes, toile phono-absorbante **Snowsound-Fiber Textiles 3 Melange**. Tissu amovible et lavable.

7SEP/RCL-306

Mampara de acero cromado con ruedas, tejido fonoabsorbente **Snowsound-Fiber Textiles 3 Melange**. Tejido extraíble y lavable.

7SEP/RCL-309

Trennwand mit Rahmen aus verchromtem Stahl mit Rollen und Stoffbahn aus **Snowsound-Fiber Textiles 3 Melange** schallabsorbierendem Gewebe. Stoff abnehmbar und waschbar.

7SEP/RCL-310

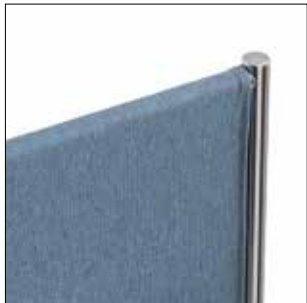

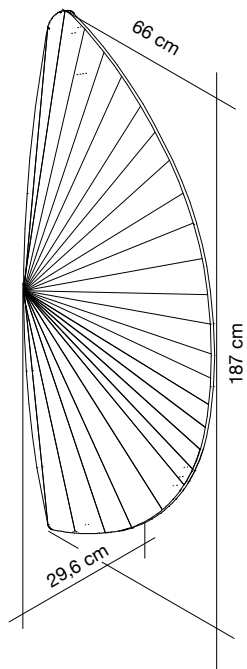

Colore
Colour

FIBER 3

Vedi pag. 171
See page 171



7PI07/PL-300



7PI07/PL-305



7PI07/PL-310

Codice/Code
Prezzo/Price

Struttura in tubolare d'acciaio verniciato con anima interna in poliesterone fonoassorbente e rivestimento in tessuto fonoassorbente **Snowsound-Fiber Textiles 3 Melange** plissettato. Tessuto asportabile e lavabile.

Powder-coated steel tubular frame with internal core in sound-absorbing polyester and cover in **Snowsound-Fiber Textiles 3 Melange** pleated sound-absorbing polyester fabric. Removable and washable fabric.

Structure en tube d'acier peint epoxy avec âme interne en polyester phono-absorbant et revêtement en textile phono-absorbant **Snowsound-Fiber Textiles 3 Melange** plissé. Tissu amovible et lavable.

Estructura de tubo de acero barnizado con núcleo interno de poliéster fonoabsorbente y cubierta de tejido fonoabsorbente **Snowsound-Fiber Textiles 3 Melange** plisado. Tejido extraíble y lavable.

Struktur aus pulverbeschichtetem Stahlrohr mit Innenkern aus schallabsorbierendem Polyester und Bezug aus **Snowsound-Fiber Textiles 3 Melange** plissiertem schallabsorbierendem Gewebe. Stoff abnehmbar und waschbar.

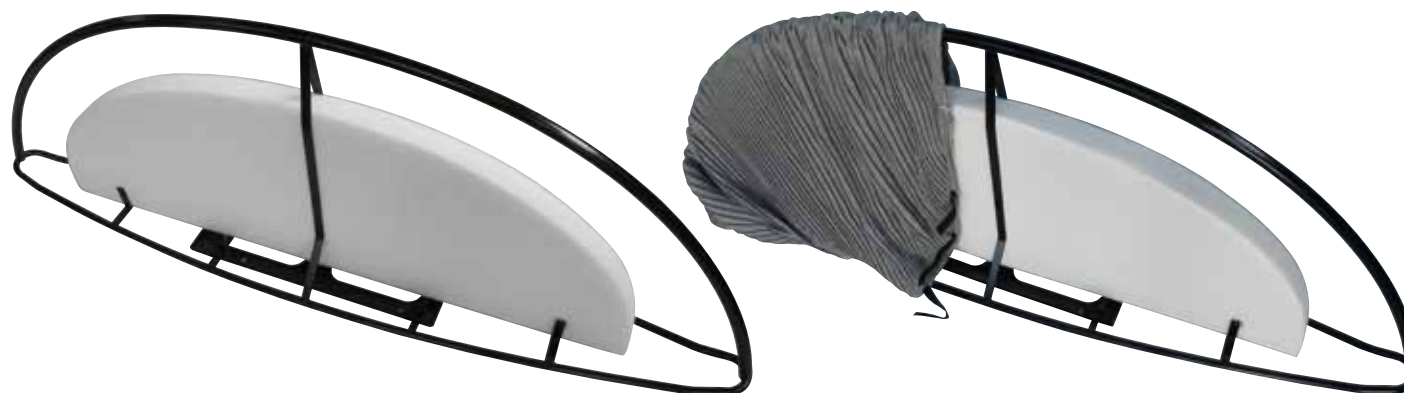



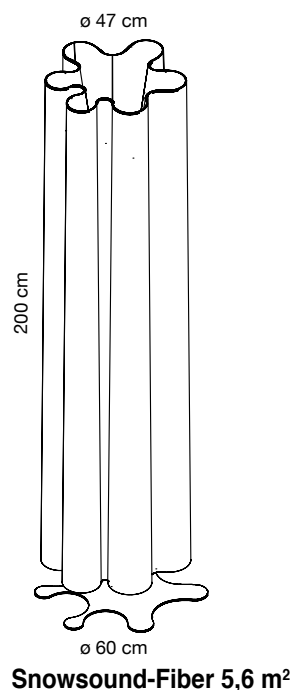

Colore **FIBER 6**
Colour **Vedi pag. 170**
See page 170



7SFD10N-600



7SFD10N-603



7SFD10N-605



7SFD10N-610

Struttura e base in acciaio verniciato nero.
Panneggio in poliestere **Snowsound-Fiber 6 Velvet**, cuciture in filo di poliestere.
Il panneggio è applicato alla struttura superiore mediante attacchi removibili in acciaio.

Structure and base in black epoxy powder-coated steel.
Drapery made of **Snowsound-Fiber 6 Velvet** polyester, stitching made of polyester thread.
The drapery is applied to the upper structure through steel removable fixings.

Structure et base en acier peint noir.
Drapérie en polyester **Snowsound-Fiber 6 Velvet**, coutures en fil de polyester.
La drapérie est appliquée à la structure supérieure à l'aide de fixations emportables en acier.

Estructura y base de acero pintado negro.
Pañería de poliéster **Snowsound-Fiber 6 Velvet**, costuras de hilo de poliéster.
La pañería se aplica a la estructura superior a través de ataques de acero extraíbles.

Struktur und Unterbau aus schwarz beschichtetem Stahl.
Drapierung aus **Snowsound-Fiber-6 Velvet**-Polyester, Nähte aus Polyester-Faden.
Die Drapierung wird mithilfe von entfernbaren Stahlhalterungen auf dem oberen Teil der Struktur angebracht.

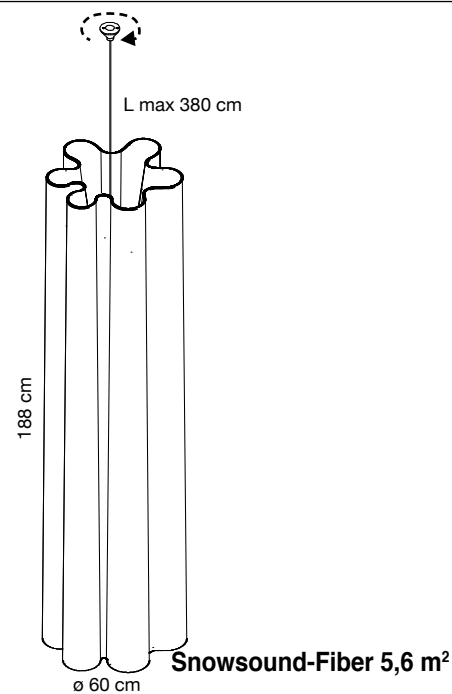

Colore **FIBER 6**
Colour **Vedi pag. 170**
See page 170



7SFD20-600



7SFD20-603



7SFD20-605



7SFD20-610

Struttura superiore in acciaio verniciato, asta superiore dotata di serracavo in metallo galvanizzato, cavo per l'appendimento in acciaio inox. Attacco a soffitto in metallo dotato di cuscinetto a sfere che consente la rotazione libera dell'intero oggetto.
Panneggio in poliestere **Snowsound-Fiber 6 Velvet**, cuciture in filo di poliestere. Il panneggio è applicato alla struttura superiore mediante attacchi removibili in acciaio.

Upper structure in epoxy powder-coated steel, top rod with galvanized steel cable clamp, stainless steel wire for hanging. Ceiling attachment equipped with metal ball bearing that allows free rotation of the entire object. Drapery made of **Snowsound-Fiber 6 Velvet** polyester, stitching made of polyester thread. The drapery is applied to the upper structure through steel removable fixings.

Structure supérieure en acier peint, tige supérieure avec serre-câble en métal galvanisé, câble d'accrochage en acier inox. Fixation au plafond en métal avec roulement à billes pour la libre rotation de l'objet entier. Drapérie en polyester **Snowsound-Fiber 6 Velvet**, coutures en fil de polyester. La drapérie est appliquée à la structure supérieure à l'aide de fixations emportables en acier.

Estructura superior de acero pintado, varrilla superior con abrazadera de cable en metal galvanizado, cable para colgar de acero inoxidable. Fijación en el techo de metal equipado con rodamiento de bolas que permite la libre rotación de todo el objeto. Pañería de poliéster **Snowsound-Fiber 6 Velvet**, costuras de hilo de poliéster. La pañería se aplica a la estructura superior a través de ataques de acero extraíbles.

Obere Struktur aus beschichtetem Stahl, obere Stange mit galvanisiertem Metallkabelbinder ausgestattet, Aufhängekabel aus Edelstahl. Deckenhalterung aus Metall mit Kugellager, wodurch die vollständige freie Rotation des Objekts ermöglicht wird. Drapierung aus **Snowsound-Fiber-6 Velvet**-Polyester, Nähte aus Polyester-Faden. Die Drapierung wird mithilfe von entfernbaren Stahlhalterungen auf dem oberen Teil der Struktur angebracht.



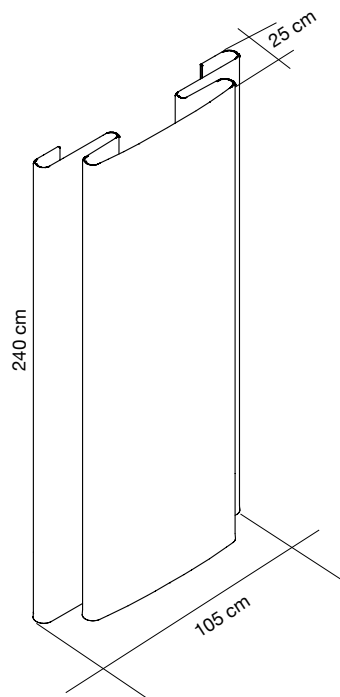

Colore
Colour

FIBER 6
Vedi pag. 170
See page 170



7SFD30-600



7SFD30-603



7SFD30-605



7SFD30-610

Snowsound-Fiber 6,5 m²



Struttura in acciaio verniciato nero.
Panneggio in poliestere **Snowsound-Fiber 6 Velvet**, cuciture in filo di poliestere.
Il panneggio è applicato alla struttura superiore mediante attacchi removibili in acciaio.

Structure in black epoxy powder-coated steel.
Drapery made of **Snowsound-Fiber 6 Velvet** polyester, stitching made of polyester thread.
The drapery is applied to the upper structure through steel removable fixings.

Structure en acier peint noir.
Drapérie en polyester **Snowsound-Fiber 6 Velvet**, coutures en fil de polyester.
La drapérie est appliquée à la structure supérieure à l'aide de fixations emportables en acier.

Estructura de acero pintado negro.
Pañería de poliéster **Snowsound-Fiber 6 Velvet**, costuras de hilo de poliéster.
La pañería se aplica a la estructura superior a través de ataques de acero extraíbles.

Struktur aus schwarz beschichtetem Stahl.
Drapierung aus **Snowsound-Fiber-6 Velvet**-Polyester, Nähte aus Polyester-Faden.
Die Drapierung wird mithilfe von entfernbaren Stahlhalterungen auf dem oberen Teil der Struktur angebracht.



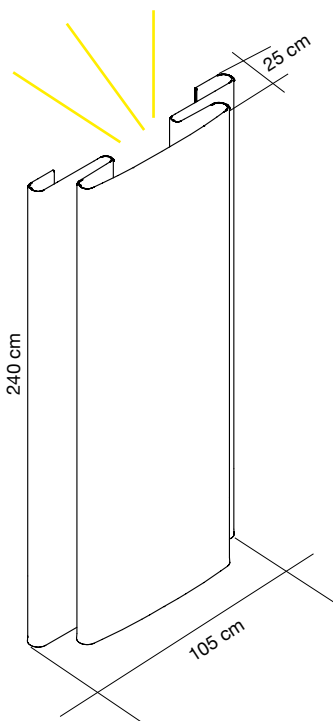

Snowsound-Fiber 6,5 m²

Colore
 Colour
FIBER 6
 Vedi pag. 170
 See page 170



7SFDL30-600



7SFDL30-603



7SFDL30-605



7SFDL30-610



Codice/Code
 Prezzo/Price

Struttura in acciaio verniciato nero.
 Panneggio in poliester **Snowsound-Fiber 6 Velvet**, cuciture in filo di poliester.
 Il panneggio è applicato alla struttura superiore mediante attacchi removibili in acciaio.
 Equipaggiata con lampada a LED potenza 25W, 3000K.

Structure in black epoxy powder-coated steel.
 Drapery made of **Snowsound-Fiber 6 Velvet** polyester, stitching made of polyester thread.
 The drapery is applied to the upper structure through steel removable fixings. Equipped with LED lamp, 25W power, 3000K.

Structure en acier peint noir.
 Drapérie en polyester **Snowsound-Fiber 6 Velvet**, coutures en fil de polyester.
 La drapérie est appliquée à la structure supérieure à l'aide de fixations emportables en acier. Equipé avec lampe LED 25W, 3000K.

Estructura de acero pintado negro.
 Pañería de poliéster **Snowsound-Fiber 6 Velvet**, costuras de hilo de poliéster.
 La pañería se aplica a la estructura superior a través de ataques de acero extraíbles.
 Equipada con lámpara de LED potencia 25W, 3000K

Struktur aus schwarz beschichtetem Stahl.
 Drapierung aus **Snowsound-Fiber-6 Velvet**-Polyester, Nähte aus Polyester-Faden.
 Die Drapierung wird mithilfe von entfernbaren Stahlhalterungen auf dem oberen Teil der Struktur angebracht. Mit LED-Lampe (25W, 3000K) ausgestattet



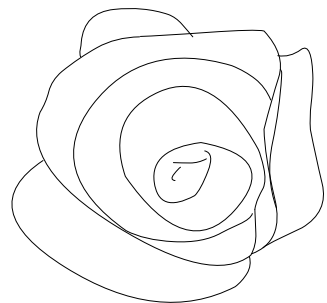

ø ~ 80 cm

Colore **FIBER 6**
Colour **Vedi pag. 170**
See page 170



7SIW80-600



7SIW80-603



7SIW80-605



7SIW80-606



7SIW80-610

Snowsound-Fiber 5 m²

Fatto a mano
Handmade

Codice/Code
Prezzo/Price

Oggetto decorativo acustico fonoassorbente realizzato con tessuti in poliester **Snowsound-Fiber 6 Velvet**. Anima centrale in conglomerato ligneo. Fissaggio a parete (viti non incluse)

Sound absorbing acoustic decorative object made of **Snowsound-Fiber 6 Velvet** polyester fabric. Central core in wood conglomerate. Wall mounting (screws not included).

Objet décoratif phono-absorbant en tissu de polyester **Snowsound-Fiber 6 Velvet**. Noyau central en conglomerat de bois. Pour fixation murale (vis pas fournies)

Objeto decorativo acústico fonoabsorbente que se realizó con tela de poliéster **Snowsound-Fiber 6 Velvet**. Bastidor central de aglomerado de madera. Fijación mural (tornillos no incluidos)

Schalldämpfendes Dekor-Objekt aus Polyester-Gewebe **Snowsound-Fiber 6 Velvet**. Zentrales Gestell aus Holzkonglomerat. Wandbefestigung (Schrauben nicht mitgeliefert)

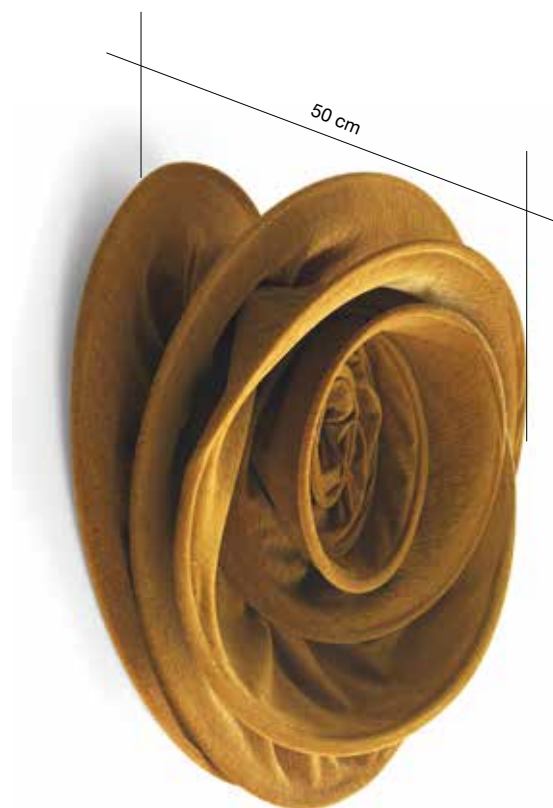

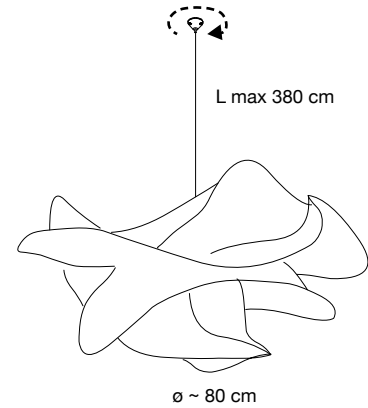

Snowsound-Fiber 5 m²

Fatto a mano
Handmade

Colore **FIBER 6**
Colour **Vedi pag. 170**
See page 170



Codice/Code
Prezzo/Price

7SIC80-600

7SIC80-603

7SIC80-605

7SIC80-606

7SIC80-610

Oggetto decorativo acustico fonoassorbente realizzato con tessuti in poliester **Snow-sound-Fiber 6 Velvet**. Anima centrale in conglomerato ligneo.
Completo di cavo e attacco a soffitto in metallo dotato di cuscinetto a sfere che consente la rotazione libera dell'intero oggetto.

Sound absorbing acoustic decorative object made of **Snowsound-Fiber 6 Velvet** polyester fabric. Central core in wood conglomerate.
With steel cable and ceiling attachment equipped with metal ball bearing that allows free rotation of the entire object.

Objet décoratif phono-absorbant en tissu de polyester **Snowsound-Fiber 6 Velvet**. Noyau central en conglomerat de bois.
Avec câble en acier et fixation au plafond en métal avec roulement à billes pour la libre rotation de l'objet entier.

Objeto decorativo acústico fonoabsorbente que se realizó con tela de poliéster **Snow-sound-Fiber 6 Velvet**. Bastidor central de aglomerado de madera.
Completo de cable de acero y fijación en el techo de metal equipado con rodamiento de bolas que permite la libre rotación de todo el objeto.

Schalldämpfendes Dekor-Objekt aus Polyester-Gewebe **Snowsound-Fiber 6 Velvet**. Zentrales Gestell aus Holzkonglomerat. Mit Stahlseile und Deckenhalterung aus Metall mit Kugellager, wodurch die vollständige freie Rotation des Objekts ermöglicht wird.





SNOWSOUND

FIBER TEXTILES



CAMP25/160

ESPOSITORE DA PARETE

Lunghezza 160 cm

con **41 campioni Fiber Textiles** 70x100 cm
(gamma completa di colori)

WALL DISPLAY

Lenght 160 cm

with **41 Fiber Textiles samples** 70x100 cm
(full-range of colours)



CAMP25/80

ESPOSITORE DA PARETE

Lunghezza 80 cm

con **20 campioni Fiber Textiles** 70x100 cm
(selezione fissa di colori)

WALL DISPLAY

Lenght 80 cm

with **20 Fiber Textiles samples** 70x100 cm
(fixed colours selection)

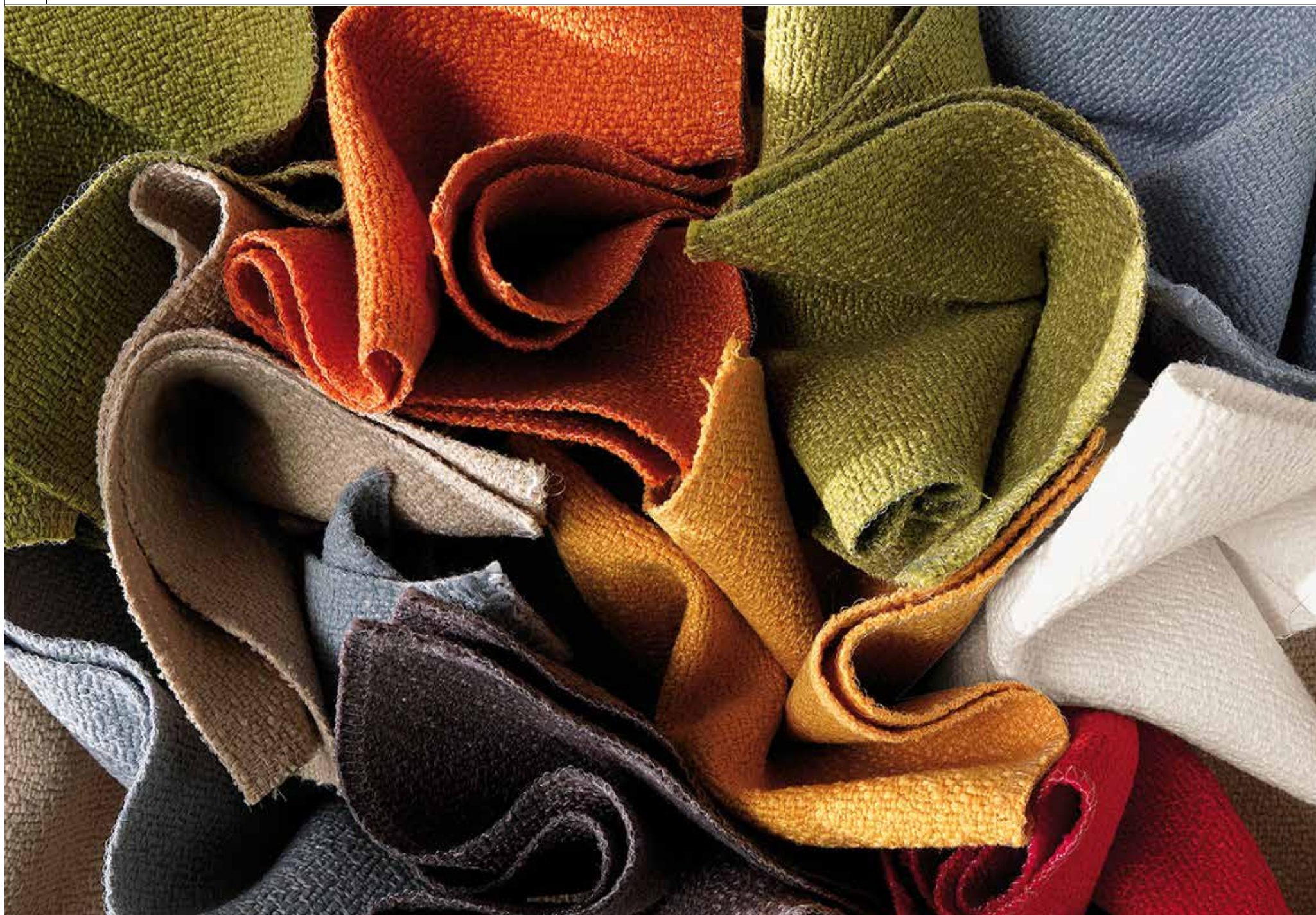

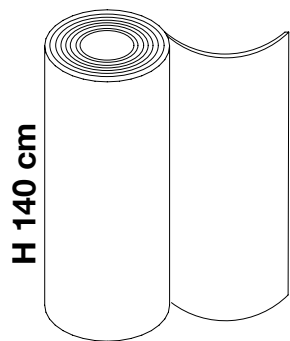

Peso: 510 g/m² - 714 g/metro lineare
 Weight: 510 g/m² - 714 g/linear meter
H = 140 cm (tolleranza / tolerance 0 + 3 cm)

X (min 6 m-max 25 m)

Rotolo (pezza) da 25 metri lineari H rotolo 140 cm

Il taglio è sempre all'unità di metro (6,7,8,9,10 24 m)

Roll of 25 linear meters H 140 cm

Cutting is always by meter only (6,7,8,9,10,..... 24 m)

Rouleau de 25 mètres linéaires H 140 cm

La coupe est toujours au mètre (6,7,8,9,10 24 m)

Rollo de 25 mts. lineales de altura 140 cms

El corte del tejido se hace solamente por metros (6,7,8,9,10 24 m)

Rolle mit 25 Laufmetern B=140 cm

Zuschnitt nur per Meter (6,7,8,9,10,....24 Meter)

Tempi di consegna 3/4 settimane (mese di agosto escluso)

Lead time 3/4 weeks (month of August excluded)

Délai d'expédition 3/4 semaines (sauf le mois d'Août)

Tiempos de entrega 3/4 semanas (mes de Agosto no incluido)

Lieferzeit 3/4 Wochen (ausgenommen August)

X = lunghezza rotolo, compresa tra 6 e 25 m / X = roll length, between 6 and 25 m / X = longueur du rouleau, comprise entre 6 et 25 m

X = longitud del rollo, entre 6 y 25 m / X = Rollenlänge, zwischen 6 und 25 m

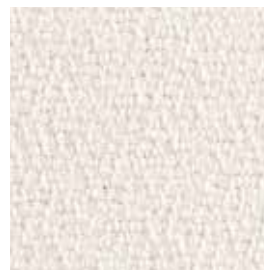

7F1/X-0001



7F1/X-1008



7F1/X-2005

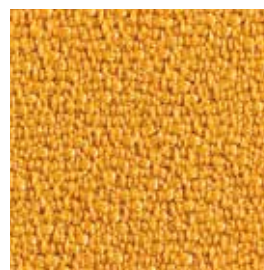

7F1/X-3008

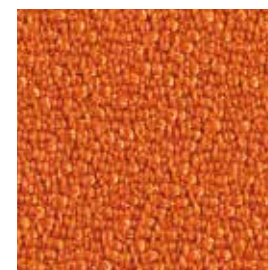

7F1/X-4030

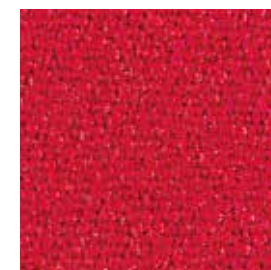

7F1/X-4027



7F1/X-7004



7F1/X-8004



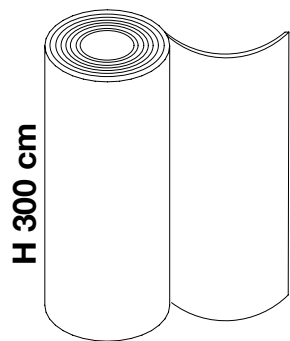

Peso: 221 g/m² - 663 g/metro lineare
 Weight: 221 g/m² - 663 g/linear meter

H = 300 cm (tolleranza / tolerance 0 + 3 cm)

X (min 6 m-max 25 m)

Rotolo (pezza) da 25 metri lineari H rotolo 300 cm

Il taglio è sempre all'unità di metro (6,7,8,9,10 24 m)

Roll of 25 linear meters H 300 cm

Cutting is always by meter only (6,7,8,9,10,..... 24 m)

Rouleau de 25 mètres linéaires H 300 cm

La coupe est toujours au mètre (6,7,8,9,10 24 m)

Rollo de 25 mts. lineales de altura 1300 cms.

El corte del tejido se hace solamente por metros (6,7,8,9,10 24 m)

Rolle mit 25 Laufmetern B=300 cm

Zuschnitt nur per Meter (6,7,8,9,10,....24 Meter)

Tempi di consegna 3/4 settimane (mese di agosto escluso)

Lead time 3/4 weeks (month of August excluded)

Délai d'expédition 3/4 semaines (sauf le mois d'Août)

Tiempos de entrega 3/4 semanas (mes de Agosto no incluido)

Lieferzeit 3/4 Wochen (ausgenommen August)

X = lunghezza rotolo, compresa tra 6 e 25 m / **X** = roll length, between 6 and 25 m / **X** = longueur du rouleau, comprise entre 6 et 25 m

X = longitud del rollo, entre 6 y 25 m / **X** = Rollenlänge, zwischen 6 und 25 m



7F2.3/X-200

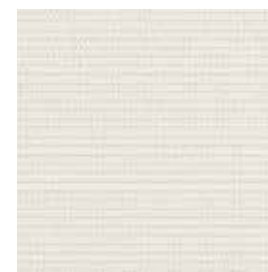

7F2.3/X-201



7F2.3/X-202

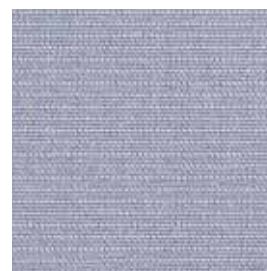

7F2.3/X-203



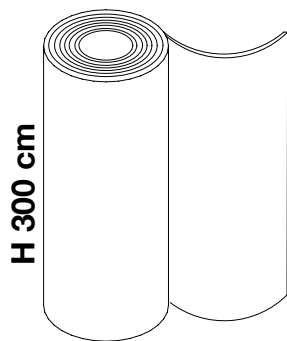

Peso: 221 g/m² - 663 g/metro lineare
Weight: 221 g/m² - 663 g/linear meter

H = 300 cm (tolleranza / tolerance 0 + 3 cm)

X (min 6 m-max 25 m)

Rotolo (pezza) da 25 metri lineari H rotolo 300 cm

Il taglio è sempre all'unità di metro (6,7,8,9,10 24 m)

Roll of 25 linear meters H 300 cm

Cutting is always by meter only (6,7,8,9,10,..... 24 m)

Rouleau de 25 mètres linéaires H 300 cm

La coupe est toujours au mètre (6,7,8,9,10 24 m)

Rollo de 25 mts. lineales de altura 300 cms

El corte del tejido se hace solamente por metros (6,7,8,9,10 24 m)

Rolle mit 25 Laufmetern B=300 cm

Zuschnitt nur per Meter (6,7,8,9,10,....24 Meter)

Tempi di consegna 3/4 settimane (mese di agosto escluso)

Lead time 3/4 weeks (month of August excluded)

Délai d'expédition 3/4 semaines (sauf le mois d'Août)

Tiempos de entrega 3/4 semanas (mes de Agosto no incluido)

Lieferzeit 3/4 Wochen (ausgenommen August)

X = lunghezza rotolo, compresa tra 6 e 25 m / **X** = roll length, between 6 and 25 m / **X** = longueur du rouleau, comprise entre 6 et 25 m

X = longitud del rollo, entre 6 y 25 m / **X** = Rollenlänge, zwischen 6 und 25 m



7F2R.3/X-200

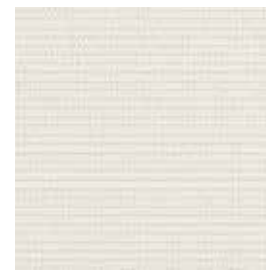

7F2R.3/X-201



7F2R.3/X-202

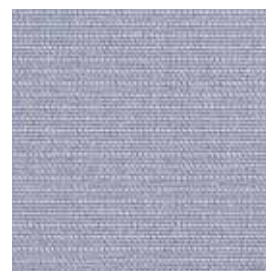

7F2R.3/X-203



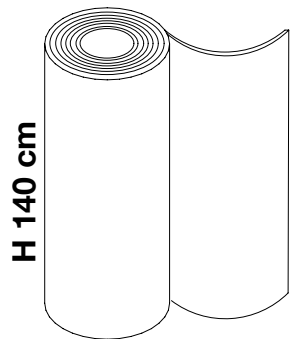

H 140 cm

Peso: 340 g/m² - 476 g/metro lineare
Weight: 340 g/m² - 476 g/linear meter

H = 140 cm (tolleranza / tolerance 0 + 3 cm)

X (min 6 m-max 25 m)

Rotolo (pezza) da 25 metri lineari H rotolo 140 cm

Il taglio è sempre all'unità di metro (6,7,8,9,10 24 m)

Roll of 25 linear meters H 140 cm

Cutting is always by meter only (6,7,8,9,10,..... 24 m)

Rouleau de 25 mètres linéaires H 140 cm

La coupe est toujours au mètre (6,7,8,9,10 24 m)

Rollo de 25 mts. lineales de altura 140 cms

El corte del tejido se hace solamente por metros (6,7,8,9,10 24 m)

Rolle mit 25 Laufmetern B=140 cm

Zuschnitt nur per Meter (6,7,8,9,10,....24 Meter)

Tempi di consegna 3/4 settimane (mese di agosto escluso)

Lead time 3/4 weeks (month of August excluded)

Délai d'expédition 3/4 semaines (sauf le mois d'Août)

Tiempos de entrega 3/4 semanas (mes de Agosto no incluido)

Lieferzeit 3/4 Wochen (ausgenommen August)

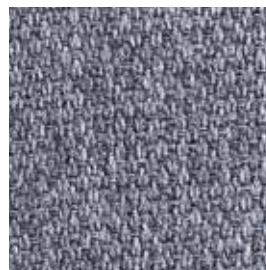

7F3/X-300



7F3/X-304



7F3/X-303



7F3/X-305

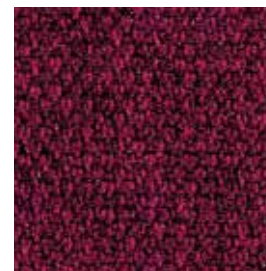

7F3/X-306



7F3/X-307



7F3/X-308

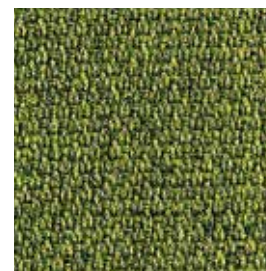

7F3/X-309

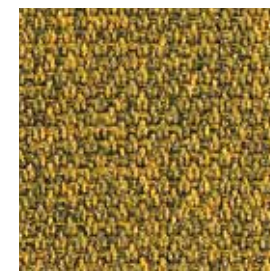

7F3/X-310



7F3/X-302

X = lunghezza rotolo, compresa tra 6 e 25 m / **X** = roll length, between 6 and 25 m / **X** = longueur du rouleau, comprise entre 6 et 25 m

X = longitud del rolo, entre 6 y 25 m / **X** = Rollenlänge, zwischen 6 und 25 m



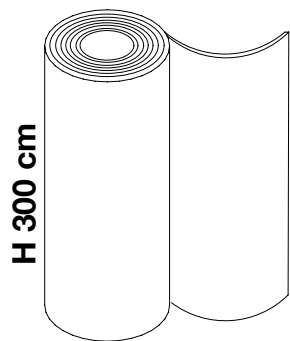

Peso: 425 g/m² - 1275 g/metro lineare
Weight: 425 g/m² - 1275 g/linear meter

H = 300 cm (tolleranza / tolerance 0 + 3 cm)

X (min 6 m-max 25 m)

Rotolo (pezza) da 25 metri lineari H rotolo 300 cm

Il taglio è sempre all'unità di metro (6,7,8,9,10 24 m)

Roll of 25 linear meters H 300 cm

Cutting is always by meter only (6,7,8,9,10,..... 24 m)

Rouleau de 25 mètres linéaires H 300 cm

La coupe est toujours au mètre (6,7,8,9,10 24 m)

Rollo de 25 mts. lineales de altura 300 cms

El corte del tejido se hace solamente por metros (6,7,8,9,10 24 m)

Rolle mit 25 Laufmetern B=300 cm

Zuschnitt nur per Meter (6,7,8,9,10,....24 Meter)

Tempi di consegna 3/4 settimane (mese di agosto escluso)

Lead time 3/4 weeks (month of August excluded)

Délai d'expédition 3/4 semaines (sauf le mois d'Août)

Tiempos de entrega 3/4 semanas (mes de Agosto no incluido)

Lieferzeit 3/4 Wochen (ausgenommen August)

X = lunghezza rotolo, compresa tra 6 e 25 m / X = roll length, between 6 and 25 m / X = longueur du rouleau, comprise entre 6 et 25 m

X = longitud del rollo, entre 6 y 25 m / X = Rollenlänge, zwischen 6 und 25 m

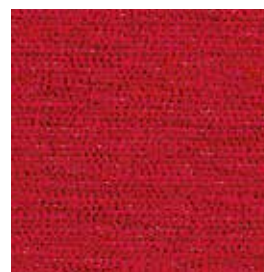

7F6/X-600

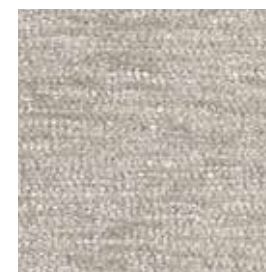

7F6/X-604



7F6/X-608



7F6/X-601

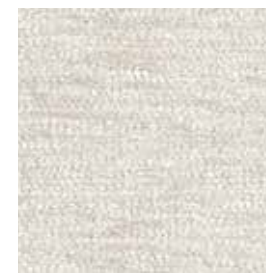

7F6/X-605



7F6/X-609



7F6/X-602



7F6/X-606



7F6/X-610

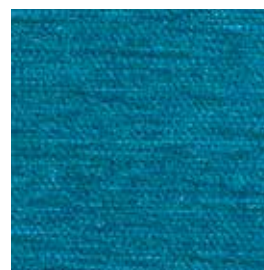

7F6/X-603



7F6/X-607

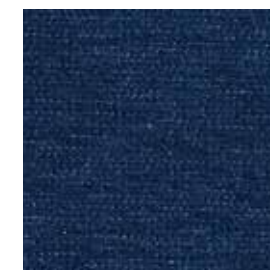

7F6/X-611

FIBER 8 BOUCLE'



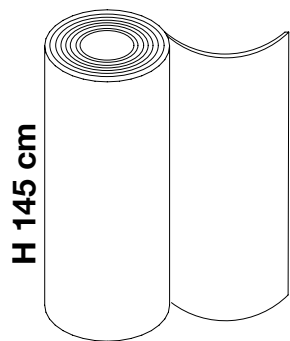

H 145 cm

Peso: 460 g/m² - 667 g/metro lineare
Weight: 460 g/m² - 667 g/linear meter

H = 145 cm (tolleranza / tolerance 0 + 3 cm)

X (min 6 m-max 25 m)

Rotolo (pezza) da 25 metri lineari H rotolo 145 cm

Il taglio è sempre all'unità di metro (6,7,8,9,10 24 m)

Roll of 25 linear meters H 145 cm

Cutting is always by meter only (6,7,8,9,10,..... 24 m)

Rouleau de 25 mètres linéaires H 145 cm

La coupe est toujours au mètre (6,7,8,9,10 24 m)

Rollo de 25 mts. lineales de altura 145 cms

El corte del tejido se hace solamente por metros (6,7,8,9,10 24 m)

Rolle mit 25 Laufmetern B=145 cm

Zuschnitt nur per Meter (6,7,8,9,10,....24 Meter)

Tempi di consegna 3/4 settimane (mese di agosto escluso)

Lead time 3/4 weeks (month of August excluded)

Délai d'expédition 3/4 semaines (sauf le mois d'Août)

Tiempos de entrega 3/4 semanas (mes de Agosto no incluido)

Lieferzeit 3/4 Wochen (ausgenommen August)

X = lunghezza rotolo, compresa tra 6 e 25 m / X = roll length, between 6 and 25 m / X = longueur du rouleau, comprise entre 6 et 25 m

X = longitud del rollo, entre 6 y 25 m / X = Rollenlänge, zwischen 6 und 25 m

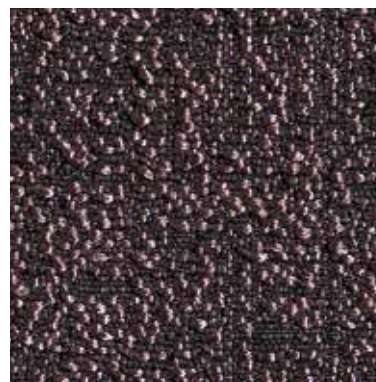

Fronte / Front

7F8/X-800

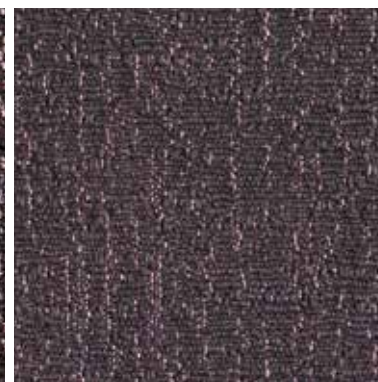

Retro / Back

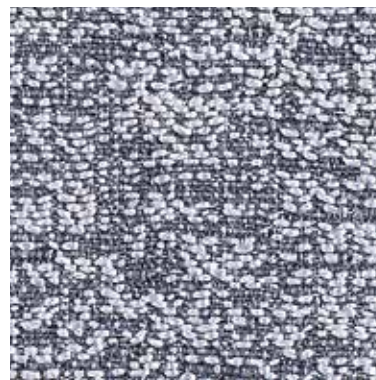

Fronte / Front

7F8/X-801

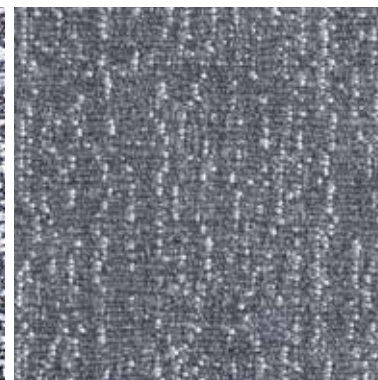

Retro / Back

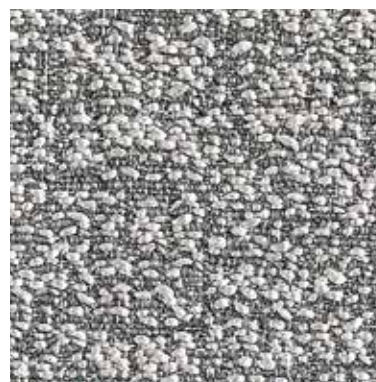

Fronte / Front

7F8/X-802

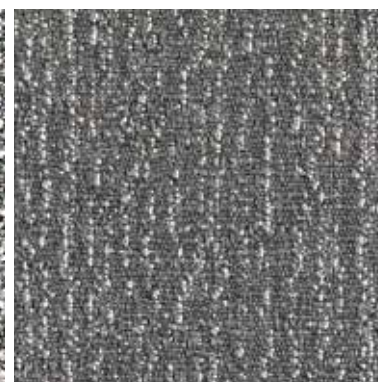

Retro / Back

CONDIZIONI GENERALI DI VENDITA

1. Il presente listino annulla e sostituisce i precedenti e non costituisce offerta.
2. I prezzi dei prodotti possono essere variati dalla venditrice in qualsiasi momento senza preavviso; tutti i prezzi non sono comprensivi di montaggio.
3. La venditrice si riserva la facoltà di modificare, a proprio insindacabile giudizio e senza preavviso alcuno, i materiali costruttivi, le caratteristiche tecniche ed estetiche, nonché le dimensioni dei prodotti.
4. Le immagini dei prodotti sono puramente indicative.
5. La vendita è regolata, oltre che dalle condizioni particolari volta a volta pattuite, dalle presenti condizioni generali, che si reputano conosciute dall'acquirente; eventuali clausole derogatorie a quanto previsto nelle presenti condizioni generali di vendita devono risultare per iscritto.
6. Le proposte d'acquisto e/o gli ordini dell'acquirente sono condizionati all'accettazione espressa o all'inizio dell'esecuzione del contratto da parte della venditrice, nei casi in cui ciò sia consentito. Qualsiasi successiva modifica al contratto di vendita non sarà valida e vincolante ove non risulti da atto scritto e sottoscritto dalla parte nei cui confronti tale modifica viene invocata.
7. Conformemente all'articolo 1510 codice civile, la consegna dei beni venduti si ha con la rimessione degli stessi al vettore o allo spedizioniere, sicché i beni stessi viaggiano a rischio e pericolo dell'acquirente; ciò vale anche nei casi in cui la merce venga venduta franco arrivo all'indirizzo dell'acquirente. Ogni eventuale richiesta, reclamo e/o azione relativi alla spedizione o al trasporto della merce dovrà essere promossa dall'acquirente direttamente nei confronti dello spedizioniere o del vettore. Ogni eventuale danno, perdita o avaria dei beni venduti dipendente dalla spedizione o dal trasporto dei medesimi non esonera l'acquirente dal pagamento del prezzo convenuto.
8. Il termine di consegna è indicativo e non tassativo; lo stesso potrà essere ritardato senza alcun obbligo di indennizzo o risarcimento di eventuali danni diretti o indiretti subiti dall'acquirente per la ritardata consegna e senza che ciò possa comunque comportare la risoluzione del contratto di vendita per inadempimento della venditrice.
9. Fatti salvi i casi di forza maggiore, in caso di scioperi ed in tutti gli altri casi che impediscano temporaneamente alla venditrice di regolarmente adempiere al contratto di vendita, è fatto salvo il diritto della medesima venditrice di recedere dal contratto, senza che l'acquirente sia legittimato ad eventuali pretese di danno, fatta salva nell'ipotesi di recesso la restituzione di quanto eventualmente versato a titolo di acconto.
10. Il pagamento del prezzo di vendita dei prodotti dovrà avvenire presso la sede della venditrice. In caso di pagamento ritardato, l'acquirente sarà automaticamente costituito in mora e sarà tenuto al pagamento degli interessi nella misura e con la decorrenza stabilita dal D.Lgs. 231/2002 per i ritardi di pagamento nelle transazioni commerciali.
11. La venditrice non risponde degli eventuali vizi dei prodotti conosciuti o conoscibili da parte dell'acquirente, che non abbia immediatamente respinto la merce. Le contestazioni od i reclami sulle quantità dei prodotti devono essere segnalate all'atto della consegna, con annotazione sul relativo documento di trasporto. La eventuale sostituzione del prodotto non significa accettazione della contestazione o del reclamo. L'accredito all'acquirente verrà fatto solo dopo la restituzione dei prodotti difettosi ed a condizione che sia stata riconosciuta o altrimenti accertata la responsabilità dalla venditrice.
12. I disegni, i modelli, i grafici e le altre informazioni tecniche dei prodotti oggetto di vendita, così come i campioni, i cataloghi, le fotografie e materiali simili, rimangono sempre di proprietà intellettuale della venditrice e non possono pertanto essere copiati, né trasmessi ad altri, né utilizzati in altro modo.
13. Le somme versate a titolo di caparra confirmatoria potranno essere ritenute dalla venditrice in caso di revoca dell'ordine e/o in ogni altro caso di inadempimento dell'acquirente che giustifichi il recesso della venditrice, salvo il diritto di chiedere l'adempimento del contratto e salvo altresì il diritto di chiedere il risarcimento del maggiore danno. Per converso, nel caso di adempimento da parte dell'acquirente dei propri obblighi contrattuali, le somme da questi versate a titolo di caparra confirmatoria saranno imputate al pagamento del prezzo; le stesse, così come gli eventuali acconti, saranno comunque infruttifere di interessi.
14. L'eventuale tolleranza di una delle parti di comportamenti dell'altra posti in essere in violazione delle clausole che regolano la vendita non costituisce rinuncia ai diritti derivanti dalle clausole violate né al diritto di esigere l'esatto adempimento di tutti i termini e condizioni previsti dal contratto di vendita.
15. La venditrice mantiene la proprietà dei prodotti consegnati fino al completo pagamento del prezzo indicato in fattura. Fino a tale data i prodotti consegnati sono considerati solo come depositati presso l'acquirente. Quest'ultimo si accolla quindi il rischio di danni che i prodotti depositati possano subire imputabili a qualsiasi causa.
16. L'acquirente è invitato a prestare particolare attenzione sul fatto che non tutti i prodotti riportati nel presente listino sono compatibili con il mercato statunitense o con quello canadese. Conseguentemente, qualora l'acquirente intendesse utilizzare o esportare detti prodotti negli Stati Uniti d'America e/o, in ogni caso, in qualsiasi altro paese extra UE, è obbligato a preventivamente contattare l'ufficio commerciale della venditrice per avere la conferma che il prodotto interessato risponda a tutti i requisiti tecnici ed agli standard legali previsti a tutela dei consumatori finali del mercato di destino. La venditrice declina ogni responsabilità conseguente alle iniziative assunte dall'acquirente senza essere stata preventivamente informata ed indipendentemente dall'eventuale autorizzazione scritta della venditrice all'esportazione e/o all'uso del prodotto in un paese extra UE.
17. L'acquirente è tenuto ad informare i propri clienti e/o gli utilizzatori finali sulle caratteristiche del prodotto al fine di ridurre al minimo il rischio di un uso improprio che potrebbe esporre la venditrice a possibili ragioni di danno. In difetto di tale attività informativa preventiva, l'acquirente esonera espressamente la venditrice da qualsiasi ipotetica responsabilità.
18. La venditrice garantisce la conformità dei prodotti alle specifiche indicate nella conferma d'ordine, fatte salve le tolleranze ritenute accettabili dalla produzione industriale.
19. La venditrice non garantisce l'idoneità dei prodotti per scopi particolari e/o usi speciali, salvo specifica richiesta dell'acquirente espressamente accettata per iscritto dalla venditrice e riportata nella relativa conferma d'ordine; l'acquirente deve assicurarsi che gli eventuali standard specifici e/o requisiti legali richiesti siano specificati nella relativa conferma d'ordine della venditrice.
20. Le informazioni della venditrice sull'idoneità specifica dei prodotti sono puramente indicative.
21. Eventuali attività di assistenza e/o calcolo effettuate dalla venditrice sui prodotti, sono da considerarsi puramente indicative e non vincolanti costituendo un mero suggerimento sul posizionamento di massima dei prodotti, ogni dato suggerito deve essere in ogni caso verificato compiutamente dall'acquirente; va da sé che trattandosi comunque di meri suggerimenti non vincolanti, la venditrice non si assume alcuna responsabilità sui risultati di tali attività.
22. Poiché le applicazioni dei prodotti fatte dall'acquirente sono fuori dal controllo della venditrice, quest'ultima non è responsabile per l'uso effettivo dei prodotti; la venditrice non è responsabile per eventuali danni e/o perdite derivanti dall'applicazione non corretta o insolita dei prodotti.
23. In considerazione della particolarità dei prodotti Snowsound-Fiber, sebbene la venditrice si sforzi di mantenere alti livelli di qualità, sono da ritenersi accettabili tre difetti ogni 25 metri con altezza del rotolo fino a 150 cm ed il doppio dei difetti per rotolo con altezza superiore ai 280 cm; la venditrice si riserva comunque la facoltà di scontare per ogni difetto riscontrato una quantità di materiale ritenuta idonea a compensare la difettosità accertata. Non sono accettati resi per prodotti e/o pezze tagliati a misura.
24. L'annullamento di un ordine da parte dell'acquirente è consentito solo in casi eccezionali e previo consenso scritto da parte della venditrice.
25. Nel caso di ordini di prodotti e/o colori fuori standard l'acquirente deve acquistare l'intera produzione effettuata appositamente.
26. Salvo diversa pattuizione e salvo il caso di dolo, la responsabilità della venditrice per i prodotti venduti è limitata ad un importo pari a tre volte il valore della conferma d'ordine, anche in caso di colpa grave.
27. Tutte le controversie che dovessero insorgere in relazione alla vendita, suoi atti modificativi ed esecutivi, comprese quelle inerenti alla validità, efficacia, interpretazione, esecuzione e risoluzione del contratto, saranno devolute alla competenza esclusiva del Foro di Milano.
28. In ogni caso, prima di procedere all'acquisto dei prodotti è necessario consultare le condizioni di vendita, le caratteristiche tecniche e le seguenti ulteriori:

AVVERTENZE

- prima di procedere all'installazione dei prodotti è necessario verificare la portanza della parete/pavimento/superficie su cui verranno collocati i prodotti assicurandosi che siano idonei al tipo di utenza e/o di utilizzo a cui sono destinati;
- i prodotti non sono idonei all'uso da parte di bambini;
- i prodotti non sono idonei ad essere utilizzati in ambienti esterni;
- i prodotti applicati a parete/pavimento/superficie prevedono l'installazione con dispositivi di ancoraggio che non compaiono nelle illustrazioni del catalogo;
- i prodotti devono essere montati e/o installati esclusivamente da personale tecnico competente utilizzando strumenti ed attrezzi adatti allo scopo;
- prima di procedere al montaggio ed all'installazione dei prodotti è necessario leggere attentamente le istruzioni allegate ai prodotti, prestando particolare attenzione sia alle avvertenze che ai disegni esplicativi; qualora le istruzioni non fossero allegate contattare l'ufficio tecnico della venditrice;
- per fissare i prodotti a parete/pavimento/superfici, è necessario utilizzare dei dispositivi di fissaggio adeguati ed in grado di resistere alle forze generate; in ogni caso è necessario utilizzare degli elementi di sostegno idonei a reggere ogni singola struttura;
- in caso di installazione non corretta e/o in caso di superamento dei carichi massimi indicati nel presente listino e/o nelle istruzioni allegate ai singoli prodotti, si potrebbe creare una situazione di pericolo, i prodotti potrebbero collassare, cadere e causare danni a cose e/o persone: non superare mai i carichi evidenziati;
- in caso di dubbi sulle modalità di installazione e/o sulla portanza della parete/pavimento/superficie su cui verrà collocato il prodotto non procedere alla installazione;
- attenersi alle istruzioni e alle composizioni riportate nel presente listino; per composizioni differenti e/o per ulteriori informazioni sui prodotti o sulle modalità di installazione degli stessi contattate l'ufficio tecnico della venditrice.
- leggere differenze di colore fra una partita e l'altra sono da considerarsi normali attese le tolleranze ritenute accettabili per la produzione industriale;
- Il testo facente fede è esclusivamente quello in lingua italiana, le traduzioni hanno la finalità esclusiva di semplificarne la lettura.

GENERAL TERMS OF SALE

1. This price list cancels and replaces the previous ones and is not a proposal.
2. The product prices may be changed by the vendor at any moment without prior notice; all prices are not inclusive of installation.
3. The vendor reserves the right to alter the construction materials, the technical and visual characteristics and also the dimensions of the products, at its own unquestionable discretion and without any prior notice.
4. Product images are purely indicative.
5. In addition to the specific terms agreed each time, sale is governed by these general terms, which are considered to be known by the purchaser; any clauses derogating from these general terms of sale must be in writing.
6. The purchaser's purchase proposals and/or orders are conditional upon the vendor expressly accepting or starting fulfilment of the agreement, in cases where this is permitted. Any subsequent amendment to the sales agreement will not be valid and binding unless entered in a written document signed by the party being asked to accept this amendment.
7. In compliance with article 1510 of the Italian Civil Code, delivery of the goods sold is with remittance thereon to the carrier or forwarder, so that the goods travel at the purchaser's risk and danger; this also applies in cases where the goods are sold free to the purchaser's address. Any other request, complaint and/or action relating to shipment or transport of the goods must be brought by the purchaser directly against the forwarder or the carrier. Any damage, loss or breakage of the goods sold which is attributable to shipment or transport thereof will not exempt the purchaser from liability for payment of the agreed price.
8. The delivery time is indicative and not binding; it may be delayed without any obligation of indemnity or compensation of any direct or consequential damages suffered by the purchaser as a result of late delivery and without this leading to termination of the sales agreement due to the vendor's non-fulfilment.
9. With the exception of cases of force majeure, in the case of strikes and all other cases which temporarily prevent the vendor from fulfilling the sales agreement properly, the vendor is entitled to withdraw from the agreement, without the purchaser being entitled to claim any damages, except for the repayment in the case of withdrawal, of any amount paid as an advance.
10. Payment of the sale price of the products must be made at the vendor's registered office. In the case of late payment, the purchaser will automatically be placed in arrears and will be required to pay interest in the amount and from the time required by Legislative Decree 231/2002 for late payment in commercial transactions.
11. The vendor is not liable for any defects of the products known or knowable to the purchaser, who has not immediately refused to accept delivery of the goods. Disputes or complaints over the product quantities must be notified upon delivery, with noting on the relative transport document. Replacement of the product does not signify acceptance of the claim or complaint. The purchaser will only be credited the amount after the faulty products have been returned and provided that the vendor's liability has been recognised or otherwise ascertained.
12. The drawings, models, graphs and other technical information on the products being sold, and also samples, catalogues, photographs and similar materials, always remain the intellectual property of the vendor and may not be copied, or transmitted to others, or used in any other way.
13. The amounts paid by way of a deposit may be withheld by the vendor if the order is cancelled and/or in all other cases of non-fulfilment by the purchaser which justifies the vendor's withdrawal, without prejudice to the right to request fulfilment of the agreement and also the right to demand compensation of greater damages. In contrast, if the purchaser fulfils its contractual obligations, the amounts paid by way of deposit will be allocated to payment of the price; said amounts, and all other advances, will be non-interest-bearing.
14. Any tolerance by one of the parties of the other's conduct which breaches the clauses governing sale does not constitute waiving of the rights deriving from the breached clauses nor the right to demand precise fulfilment of all the terms and conditions contained in the sales agreement.
15. The vendor maintains ownership of the products until complete payment of the price indicated on the invoice. Up until that date, the products delivered are considered as only held in deposit by the purchaser. The latter therefore accepts the risk of damages to the products deposited attributable to any cause.
16. The purchaser is invited to pay particular attention to the fact that not all products on the price list are compatible with the US or Canadian markets. Consequently, if intending to use or export said products into the USA and/or, in any case, into any other non-EU country, the purchaser is required to contact the vendor's sales office beforehand for confirmation that the product concerned satisfies all technical requirements and legal standards protecting final consumers on the market of destination. The vendor declines all liability consequent upon initiatives taken by the purchaser without it having been informed beforehand and irrespective of any written authorisation of the vendor for exportation to and/or use of the product in a non-EU country.
17. The purchaser is required to inform its own customers and/or final users of the product characteristics, in order to reduce to a minimum the risk of improper use which could expose the vendor to possible claims of damage. In the case of failure to provide this prior information, the purchaser expressly exempts the vendor from any hypothetical liability.
18. The seller guarantees the conformity of the products to the specifications indicated in the order confirmation, except for the tolerances considered acceptable in industrial production.
19. The seller does not guarantee the suitability of the products for particular purposes and/or special uses, unless specifically requested by the buyer and expressly accepted in writing by the seller with a statement in the relative order confirmation; the buyer must ensure that any specific standards and/or legal requirements are specified in the relative order confirmation of the seller.
20. The seller's information regarding specific suitability of the products is purely indicative.
21. Any eventual consulting and/or design activity and/or calculation carried out by the seller pertaining products is to be considered purely indicative and represents a simple suggestion concerning products' generic positioning, hence not binding. Each suggested fact must be fully verified by the buyer; the seller assumes no responsibility for the results of such activities.
22. Since the applications of the products made by the buyer are beyond the seller's control, the seller is not responsible for the actual use of the products; the seller is not responsible for any damage and/or loss resulting from incorrect or unusual application of the products.
23. In consideration of the particularity of Snowsound-Fiber products, although the seller strives to maintain high levels of quality, three defects are acceptable every 25 meters on rolls up to 150cm high and twice as many defects per roll with a height of more than 280 cm; the seller reserves the right to discount, for each defect found, a quantity of material considered suitable to compensate for the proven defect. No returns are accepted for products and/or pieces cut to size.
24. Cancellation of an order by the buyer is permitted only in exceptional cases and subject to prior written consent from the seller.
25. In case of orders containing non-standard products and/or colors, the buyer must purchase the entire production carried out specifically for this purpose.
26. Unless otherwise agreed and unless in case of fraud, the seller's liability for the products sold is limited to an amount equal to three times the value of the order confirmation, even in case of severe guilt.
27. Milan Court will be the sole court of competent jurisdiction for all disputes which may arise in relation to sale and any actions of amendment and enforcement thereof, including those relating to the validity, effectiveness, interpretation, fulfilment and termination of the agreement.
28. In any case, before purchasing the products, it is necessary to consult the terms of sale, technical characteristics and furthermore the following:

WARNINGS

- Before installing the products, check the bearing capacity of the wall/floor/surface on which the products will be positioned, ensuring they are suitable for the intended type of user/use.
- The products are not suitable for use by children.
- The products are not suitable for use outside.
- If the products are applied to the wall/floor/surface, they must be installed with anchoring devices (not shown in the catalogue).
- The products must be assembled and/or installed exclusively by skilled technical personnel, using instruments and tools appropriate for this purpose.
- Carefully read the instructions enclosed with the product before proceeding with assembly and installation, paying particular attention to the warnings and to the explanatory drawings; if the instructions are not attached, contact the vendor's technical office.
- Suitable attachment devices must be used to attach the products to the wall/floor/surfaces, which are strong enough to resist the forces generated; in any case, suitable supporting elements to support each individual element must be used.
- In the case of incorrect installation and/or weights exceeding the maximum loads indicated on this price list and/or the instructions attached to the individual products, a situation of danger could be created, the products could collapse, fall and cause damage to people and/or things: never exceed the loads indicated.
- Do not install the product in the case of any doubts over the methods of installation and/or bearing capacity of the wall/floor/surface on which the product is to be positioned.
- Comply with the instructions and compositions shown on this price list; for different compositions and/or further information on the products or installation methods, contact the vendor's technical office.
- Slight color differences between one lot and another have to be considered normal, within usual tolerances usually accepted for industrial productions.
- The authentic text is only in Italian, the translation has the mere purpose of simplifying the reading.

CONDITIONS GÉNÉRALES DE VENTE

1. Le présent catalogue des prix annule et remplace les précédents et ne constitue pas une offre.
2. Les prix des produits peuvent être changés par la venderesse à tout moment sans préavis; aucun prix ne comprend le montage.
3. La venderesse se réserve le droit de modifier, selon sa décision sans appel et sans aucun préavis, les matériaux servant à la construction, les caractéristiques techniques et esthétiques ainsi que les dimensions des produits.
4. Les images des produits sont fournies à titre purement indicatif.
5. La vente est réglementée, en plus des conditions particulières convenues à chaque fois, par les présentes conditions générales, qui sont considérées comme connues par l'acheteur; d'éventuelles clauses dérogatoires aux dispositions des présentes conditions générales de vente doivent être mises par écrit.
6. Les offres d'achat et/ou commandes de l'acheteur sont soumises à l'acceptation explicite ou au début de l'exécution du contrat par la venderesse, dans les cas où cela est possible. Aucune modification suivante au contrat de vente ne sera valide et contraignante sans acte écrit et signé par la partie contre laquelle cette modification est invoquée.
7. Conformément à l'article 1510 du code civil, la livraison des biens vendus se fait par la remise de ceux-ci au transporteur ou à l'expéditionnaire, de sorte que les dits biens voyagent aux risques et périls de l'acheteur; cette règle vaut aussi dans les cas où la marchandise est vendue franco adresse de l'acheteur. Toute éventuelle demande, réclamation et/ou action relative à l'expédition ou au transport de la marchandise devra être faite par l'acheteur directement à l'expéditionnaire ou au transporteur. Les éventuels dommages, perte ou avarie des biens vendus dépendant de leur expédition ou du transport n'exonèrent pas l'acheteur du paiement du prix convenu.
8. La date de livraison est indicative et non péremptoire; elle pourra être retardée sans aucune obligation d'indemnisation ou de dédommagement d'éventuels dommages directs ou indirects subis par l'acheteur à cause de la livraison retardée et sans que cela puisse de toute manière comporter la résiliation du contrat de vente pour inexécution de la venderesse.
9. Sauf les cas de force majeure, en cas de grèves et dans tous les autres cas qui empêchent temporairement la venderesse de remplir normalement le contrat de vente, la venderesse a le droit de résilier le contrat, sans pour autant que ce fait légitime l'acheteur à d'éventuelles prétentions de dommage, sauf, dans l'hypothèse de résiliation, la restitution des sommes éventuellement versées à titre d'acompte.
10. Le paiement du prix de vente des produits devra se faire au siège de la venderesse. En cas de paiement en retard, l'acheteur sera automatiquement mis en demeure et sera tenu de payer des intérêts au taux et dans les délais établis par le décret de loi 231/2002 régissant les retards de paiement dans les transactions commerciales.
11. La venderesse n'est pas responsable des éventuels vices des produits connus ou que l'acheteur aurait pu connaître s'il n'a pas immédiatement refusé la marchandise. Les contestations ou les réclamations sur les quantités des produits doivent être signalées au moment de la livraison, au moyen d'une note écrite sur le document de transport. L'éventuel remplacement du produit ne signifie pas l'acceptation de la contestation ou de la réclamation. Le remboursement de l'acheteur sera fait uniquement après la restitution des produits défectueux et à condition qu'ait été reconnue ou autrement établie la responsabilité de la venderesse.
12. Les dessins, les modèles, les graphiques et les informations techniques sur les produits objet de la vente, ainsi que les échantillons, les catalogues, les photos et tout le matériel similaire demeurent toujours la propriété intellectuelle de la venderesse et ne peuvent par conséquent pas être copiés, ni transmis à des tiers, ni utilisés d'aucune autre manière.
13. Les sommes versées à titre d'arrhes de confirmation pourront être retenues par la venderesse en cas de révocation de la commande et/ou dans tout autre cas d'inexécution de l'acheteur justifiant la résiliation par la venderesse, sauf le droit de demander l'exécution du contrat et aussi sauf le droit de demander le dédommagement du dommage supérieur. Au contraire, dans le cas d'exécution par l'acheteur de ses propres obligations contractuelles, les sommes qu'il aura versées à titre d'arrhes de confirmation seront imputées au paiement du prix; celles-ci, ainsi que les éventuels acomptes, ne produiront pas d'intérêts.
14. L'éventuelle tolérance par une des parties des comportements de l'autre en violation des clauses qui régissent la vente ne constitue pas une renonciation aux droits découlant des clauses violées ni au droit d'exiger l'exécution exacte de tous les termes et conditions prévus par le contrat de vente.
15. La venderesse garde la propriété des produits livrés jusqu'au paiement total du prix indiqué dans la facture. Jusqu'à cette date, les produits livrés sont considérés comme seulement déposés chez l'acheteur. Ce dernier prend donc en charge le risque des dommages que les produits déposés pourraient subir qu'ils soient imputables à n'importe quelle cause.
16. L'acheteur est invité à faire particulièrement attention au fait que tous les produits indiqués dans le présent catalogue des prix ne sont pas nécessairement compatibles avec les marchés américain ou canadien. Par conséquent, si l'acheteur a l'intention d'utiliser ou d'exporter les dits produits aux États-Unis et, dans tous les cas, dans n'importe quel autre pays extra UE, il doit préalablement contacter le bureau commercial de la venderesse pour avoir la confirmation que le produit concerné remplit toutes les exigences techniques et est conforme aux standards légaux prévus pour la protection des consommateurs finaux du marché de destination. La venderesse décline toute responsabilité pour des initiatives prises par l'acheteur dont elle n'a pas été préalablement informée et indépendamment de l'éventuelle autorisation écrite de la venderesse pour l'exportation et ou l'emploi du produit dans un pays extra UE.
17. L'acheteur est tenu d'informer ses propres clients et/ou les utilisateurs finaux des caractéristiques du produit afin de réduire au minimum le risque d'emploi impropre qui pourrait exposer la venderesse à d'éventuelles demandes de dédommagement. À défaut de cette activité d'information préventive, l'acheteur exonère expressément la venderesse de toute hypothétique responsabilité.
18. Le vendeur garantit la conformité des produits avec les spécifications indiquées dans la confirmation de la commande, sous réserve des tolérances considérées acceptables pour la production industrielle.
19. Le vendeur ne garantit pas que les produits sont appropriés pour des occasions particulières et/ou des usages spéciaux, sous réserve de demande spécifique de l'acheteur expressément acceptée par écrit par le vendeur et indiquée dans la confirmation de la commande; l'acheteur doit s'assurer que les normes spécifiques éventuelles et/ou les conditions légales exigées soient spécifiées dans la confirmation de la commande de la part du vendeur.
20. Les informations du vendeur sur la pertinence spécifique des produits sont purement indicatives.
21. Toute activité d'assistance et/ou calcul effectuée par le vendeur sur les produits est à considérer comme purement indicative et non contraignante en s'agissant d'un simple conseil sur le positionnement des produits, chaque donnée doit être dument vérifiée par l'acheteur; il est évident qu'en s'agissant de simples suggestions non contraignantes, le vendeur n'assume aucune responsabilité quant aux résultats de ces activités.
22. Etant donné que les utilisations des produits faites par l'acheteur sont en dehors du contrôle du vendeur, ce dernier n'est pas responsable pour l'utilisation effective des produits; le vendeur n'est pas responsable pour d'éventuels dommages et/ou pertes dus à l'utilisation non correcte ou inhabituelle des produits.
23. Compte tenu de la spécificité des produits Snowsound-Fiber, même si le vendeur s'efforce à garder des niveaux de qualité élevé, ont considère comme acceptable trois défauts tous les 25 mètres pour des hauteurs du rouleau jusqu'à 150 cm et le double de défauts pour des rouleaux avec une hauteur supérieure à 280 cm; le vendeur se réserve toujours la faculté d'offrir pour chaque défaut constaté une quantité de matériel estimée apte à compenser les défauts constatés. Nous n'acceptons pas de reprise pour des produits et/ou des pièces coupés sur mesure.
24. L'annulation d'une commande de la part de l'acheteur n'est autorisée qu'en des cas exceptionnels et avec l'accord écrit préalable du vendeur.
25. En cas de commandes de produits et/ou couleurs hors norme l'acheteur est tenu à acheter toute la production effectuée expressément pour lui.
26. Sauf convention contraire et sauf en cas de fraude, la responsabilité du vendeur pour les produits vendus est limitée à un montant égal au triple de la valeur de la confirmation de la commande, même en cas de faute grave.
27. Toutes les controverses qui devraient surgir relatives à la vente, à ses actes de modification et d'exécution, y compris celles concernant la validité, l'efficacité, l'interprétation, l'exécution et la résiliation du contrat, seront du ressort exclusif du Tribunal de Milan.
28. De toute manière, avant de procéder à l'achat des produits, il faut consulter les conditions de vente, les caractéristiques techniques et les autres suivantes:

MISES EN GARDE

- avant de procéder à l'installation des produits, il faut vérifier la portée maximum des murs/ sol/surfaces sur lesquelles les produits seront placés en s'assurant qu'ils soient adaptés au type d'usage et/ou d'utilisation auquel ils sont destinés;
- les produits ne doivent pas être utilisés par les enfants;
- les produits ne doivent pas être utilisés à l'extérieur des bâtiments;
- les produits appliqués aux murs/ sol/surfaces comportent l'installation avec des dispositifs d'ancrage qui ne sont pas montrés dans les illustrations du catalogue;
- les produits doivent être montés et/ou installés exclusivement par du personnel technique compétent en utilisant des instruments et outils prévus à cet effet;
- avant de procéder au montage et à l'installation des produits, il faut lire attentivement les instructions jointes aux produits, en faisant particulièrement attention tant aux instructions qu'aux dessins explicatifs; si les instructions ne sont pas jointes, contacter le bureau technique de la venderesse;
- pour fixer les produits aux murs/sol/surfaces, il faut utiliser des dispositifs de fixation adéquats et en mesure de résister aux forces générées; dans tous les cas il est nécessaire d'utiliser des éléments de soutien adéquats à supporter chaque structure en particulier;
- en cas d'installation non correcte et/ou en cas de dépassement des charges maximales indiquées dans le présent catalogue des prix et/ou dans les instructions jointes à chaque produit, une situation de danger pourrait se créer, les produits pourraient s'effondrer, céder, tomber et causer des dommages aux choses et/ou aux personnes: jamais dépasser les charges indiquées;
- en cas de doutes sur les modes d'installation et/ou sur le maximum de portée des murs/ sol/surface sur lesquels sera placé le produit, ne pas procéder à l'installation;
- s'en tenir aux instructions et aux compositions indiquées dans le présent catalogue des prix; pour des compositions différentes et/ou pour toute information supplémentaire sur les produits ou sur les modes d'installation de ceux-ci, contacter le bureau technique de la venderesse;
- légères différences de couleur entre un lot et l'autre doivent être considérées comme étant normales si dans le limite des tolérances jugées acceptables pour la production industrielle;
- le texte de référence est seulement celui en italien, les traductions ont le seul but de simplifier la lecture.

208 CONDICIONES DE VENTA

1. Esta lista de precios anula y sustituye las anteriores y no es una oferta.
2. El vendedor puede cambiar los precios de los productos en cualquier momento sin previo aviso; ninguno de los precios incluye el montaje.
3. El vendedor se reserva el derecho de modificar, a su entera discreción y sin previo aviso, los materiales de construcción, las características técnicas y estéticas así como también las dimensiones de los productos.
4. Las imágenes de los productos son meramente ilustrativas.
5. La venta se rige no sólo por las condiciones especiales acordadas caso por caso, sino también por las presentes condiciones generales, que el comprador ha de conocer; posibles cláusulas de exención a lo dispuesto en las presentes condiciones generales de venta deben figurar por escrito.
6. Las propuestas de compra y/o pedidos del comprador dependen de la aceptación o del inicio del contrato por parte del vendedor, en los casos en que esto esté permitido. Cualquier modificación posterior al contrato de venta no será válida ni vinculante si no figura en un contrato escrito, firmado por la parte en relación a la cual se pide dicha modificación.
7. En conformidad con el artículo 1510 del Código Civil, la entrega de los bienes vendidos se considera a partir de la remisión de los mismos al transportista o al agente de transporte, es decir que los bienes viajan a riesgo y peligro del comprador; esto vale también en los casos en los cuales la mercancía haya sido vendida con el transporte pagado hasta la sede del comprador. Cualquier posible petición, queja y/o acción relacionada con el envío o transporte de mercancías deberá ser efectuada por el comprador directamente contra el transportista o agente de transportes. Cualquier posible daño, pérdida o rotura de los bienes vendidos debidos a la expedición o al transporte de los mismos no exime al comprador de pagar el precio convenido.
8. El plazo de entrega es indicativo y no perentorio; el mismo podrá retrasarse sin ninguna obligación de indemnización ni compensación de los daños directos o indirectos sufridos por el comprador por la entrega tardía y sin que esto pueda llevar a la terminación del contrato de venta por incumplimiento del vendedor.
9. Excepto en los casos de fuerza mayor, en caso de huelgas y en los demás casos que impidan temporalmente al vendedor cumplir normalmente con el contrato de venta, el vendedor tendrá el derecho de rescindir el contrato, sin que el comprador pueda presentar ninguna reclamación por daños y perjuicios, salvo en el caso de cancelación, la devolución de lo pagado por adelantado.
10. El pago del precio de venta de los productos debe llevarse a cabo en las instalaciones del vendedor. En caso de demora en el pago, el comprador estará automáticamente en mora y deberá pagar intereses en la medida y con la fecha establecida por el Decreto Legislativo. 231/2002 de la morosidad en las transacciones comerciales
11. El vendedor no se hace responsable por posibles defectos de los productos identificados o identificables por parte del comprador, que no haya rechazado inmediatamente. Cualquier disputa o queja sobre las cantidades de productos deben ser indicadas en el momento de la entrega, con la anotación en el documento de transporte correspondiente. La posible sustitución del producto no implica la aceptación de la objeción o queja. El pago al comprador se realizará sólo una vez efectuada la devolución de los productos defectuosos y siempre que se haya reconocido o comprobado la responsabilidad del vendedor.
12. Los dibujos, modelos, diagramas y otra información técnica de los productos vendidos, así como las muestras, catálogos, fotografías y otros materiales similares, siguen siendo de propiedad intelectual del vendedor y no pueden ser copiados ni transmitidos a otras personas ni utilizarse de otro modo.
13. Las sumas abonadas en concepto de señal confirmatoria podrán ser retenidas por el vendedor en caso de revocación del pedido y/o ante cualquier otro caso de incumplimiento por parte del comprador que justifique la retirada del vendedor, salvo el derecho a exigir el cumplimiento del contrato y también el derecho a reclamar indemnización por daños y perjuicios adicionales. Por el contrario, en el caso de cumplimiento por parte del comprador de sus obligaciones contractuales, las cantidades pagadas en concepto de señal confirmatoria serán consideradas con el pago del precio; las mismas, así como también los pagos iniciales, serán de todos modos sin intereses.
14. Cualquier tolerancia de una de las partes a conductas iniciadas en violación de las disposiciones que rigen la venta no constituirá una renuncia a derechos que se deriven de las disposiciones violadas o el derecho a exigir el estricto cumplimiento de todos los términos y condiciones establecidos en contrato de venta.
15. El vendedor conserva la propiedad de los bienes entregados hasta el pago total del precio indicado en la factura. Hasta esa fecha, los productos entregados han de considerarse sólo como bienes depositados en la sede del comprador. Por lo tanto, este último se asume el riesgo por los daños que los mismos puedan sufrir debidos a cualquier causa.
16. El comprador ha de prestar especial atención al hecho de que no todos los productos que figuran en este catálogo son compatibles con el mercado de los EE.UU. o de Canadá. Por lo tanto, si el comprador tiene la intención de utilizar o exportar dichos productos en los Estados Unidos de América y/o, de todos modos, en cualquier otro país fuera de la UE, debe antes y imperativamente ponerse en contacto con la oficina de ventas del vendedor para confirmar que el producto en cuestión cumpla con todos los requisitos técnicos y las normas establecidas en la legislación para proteger a los consumidores en el mercado de destino. El vendedor no se asume ninguna responsabilidad con respecto a las iniciativas adoptadas por el comprador, sin haber sido informado previamente y independientemente de la posible autorización por escrito por parte del vendedor a la exportación y/o uso del producto en un país fuera de la UE.
17. El comprador está obligado a informar a sus clientes y/o usuarios finales de las características del producto para reducir al mínimo el riesgo de mal uso que podría exponer al vendedor a posibles motivos de daño. En ausencia de dicha actividad de información preventiva, el comprador libera expresamente al vendedor de cualquier responsabilidad hipotética.
18. El vendedor garantiza la conformidad de los productos a las especificaciones mencionadas en la confirmación del pedido, excepto las tolerancias que se consideren aceptables para la producción industrial.
19. El vendedor no garantiza la idoneidad de los productos para fines especiales y/o usos específicos, a menos que el comprador no la haya pedido de forma específica y que el vendedor la haya aceptado expresamente por escrito constando en la correspondiente confirmación del pedido; el comprador debe comprobar que las posibles normas específicas y/o requisitos legales exigidos consten en la correspondiente confirmación del pedido del vendedor
20. La información que facilita el vendedor con respecto a la idoneidad específica de los productos es meramente indicativa.
21. De haber una actividad de asesoramiento y/o cálculo realizada por el vendedor sobre los productos, se la deberá considerar solamente indicativa y no vinculante siendo una mera sugerencia sobre el posicionamiento general de los productos, en cualquier caso le incumbirá al comprador controlar detalladamente cada uno de los datos propuestos; es evidente que el vendedor por tratarse de meras sugerencias no vinculantes, no asume responsabilidad alguna con respecto a los resultados de dicha actividad.
22. Puesto que el vendedor no puede controlar cómo el comprador emplea el producto, el vendedor no se hace responsable por el uso concreto de los productos; el vendedor no se hace responsable por los posibles daños y/o perjuicios debidos al uso incorrecto o extraño de los productos.
23. Habida cuenta de la especificidad de los productos Snowsound-Fiber, si bien el vendedor hace todo lo que está en su poder por mantener elevados niveles de calidad, considera aceptables tres defectos cada 25 metros de rollo alto hasta 150 cm y el doble de defectos por rollo alto más de 280 cm; sin embargo, el vendedor se reserva la facultad de descontar por cada defecto detectado una cantidad de material que considere adecuada a compensar los defectos comprobados. No se aceptan devoluciones de productos y/o tejidos cortados a medida.
24. El comprador podrá cancelar un pedido sólo en casos excepcionales y previo consentimiento expreso por escrito por parte del vendedor.
25. En el caso de pedidos de productos y/o colores no estándar, el comprador deberá comprar toda la producción realizada específicamente.
26. Salvo acuerdo contrario y salvo el caso de dolo, la responsabilidad del vendedor por los productos vendidos se limita a un importe igual a tres veces el valor de la confirmación del pedido, también si hubiera culpa grave.
27. Todas las controversias que pudiesen surgir en relación con la venta, documentos modificativos y ejecutivos, incluidas las relativas a la validez, eficacia, interpretación, ejecución y terminación del contrato, serán resueltas exclusivamente por el Tribunal competente de Milán.
28. De todos modos, antes de comprar los productos es necesario leer las condiciones de venta, las especificaciones técnicas y además las siguientes:

ADVERTENCIAS

- antes de instalar los productos es necesario controlar las características de la pared/piso/superficie en donde se colocarán dichos productos, asegurándose que sean adecuados al tipo de usuario y/o de uso final;
- los productos no son adecuados para ser utilizados por niños;
- los productos no son adecuados para ser utilizados al aire libre;
- los productos aplicados a la pared/piso/superficie prevén el uso de dispositivos de anclaje que no están ilustrados en el catálogo;
- los productos deben ser montados y/o instalados exclusivamente por personal técnico cualificado utilizando los instrumentos y las herramientas específicas para dicho fin;
- antes de montar y instalar los productos es necesario leer atentamente las instrucciones adjuntas a los productos, prestando especial atención tanto a las advertencias como a los diseños de explicación; si faltan las instrucciones, póngase en contacto con la oficina técnica del vendedor;
- para fijar los productos a la pared/piso/superficies es necesario utilizar los dispositivos de sujeción adecuados capaces de resistir a las fuerzas generadas; se debe de todas formas utilizar elementos de soporte capaces de sostener cada una de las estructuras;
- en caso de montaje incorrecto y/o en caso de un exceso de las cargas máximas especificadas en la presente lista y/o en las instrucciones adjuntas a cada producto, se podría crear una situación de peligro, los productos podrían colapsar, ceder, caer y causar daños a cosas y/o personas; no exceder nunca las cargas indicadas;
- en caso de dudas acerca de cómo efectuar la instalación y/o de las características de la pared /piso/superficie sobre el cual será montado el producto, no lleve a cabo la instalación;
- siga las instrucciones y elija las combinaciones que figuran en esta lista; para combinaciones diferentes y/o otras informaciones sobre los productos o sobre el modo de instalación de los mismos, póngase en contacto con la oficina técnica del vendedor.
- - Ligeras diferencias de color entre un lote y otro deben considerarse normales de cumplirse las tolerancias que se consideren aceptables para la producción industrial;
- El texto auténtico es exclusivamente lo en idioma italiano, las traducciones tienen el único propósito de simplificar la lectura.

ALLGEMEINE VERKAUFSBEDINGUNGEN

1. Die vorliegende Preisliste hebt alle vorausgegangenen Listen auf, ersetzt sie und stellt kein Angebot dar.
2. Die Preise der Produkte können vom Verkäufer jederzeit ohne entsprechende Benachrichtigung geändert werden; keiner der Preise enthält die Montagekosten.
3. Der Verkäufer behält sich das Recht vor, nach seinem eigenen, unanfechtbaren Urteil und ohne entsprechende Benachrichtigung, Materialbeschaffenheit, technische Eigenschaften und Aussehen sowie die jeweiligen Abmessungen der Produkte zu ändern.
4. Die Produktbilder haben reinen Beispielcharakter.
5. Abgesehen von fallweise ausgehandelten Sonderkonditionen wird der Verkauf von den vorliegenden allgemeinen Bedingungen geregelt, von denen vorausgesetzt wird, dass der Käufer sie kennt; eventuell von den in den vorliegenden allgemeinen Verkaufsbedingungen abweichende Klauseln bedürfen jeweils der schriftlichen Form.
6. Die Kaufanbote und/oder Aufträge des Käufers bedürfen zuvor der ausdrücklichen Annahme bzw. in Fällen, in denen dies gestattet ist, des Beginns der Vertragserfüllung seitens des Verkäufers. Jegliche nachträgliche Änderung des Kaufvertrages ist nicht gültig und bindend, sofern nicht entsprechende schriftliche und jeweils von der Partei, die diese Änderung annehmen soll, unterzeichnete Unterlagen vorliegen.
7. Gemäß Art. 1510 Italienisches Bürgerliches Gesetzbuch (Codice Civile) findet die Lieferung der verkauften Waren bei deren Abgabe an den Transportunternehmer bzw. den Spediteur statt, so dass die Waren auf Risiko und Gefahr des Empfängers reisen; dies gilt auch in den Fällen, in denen die Ware frei Haus verkauft wird. Jeglicher Anspruch, Reklamation und/oder Klage betreffend die Lieferung oder den Transport der Waren muss vom Kunden direkt an den Transportunternehmer oder Spediteur gerichtet werden. Jeder eventuelle Schaden, Verlust oder Defekt der verkauften Waren, der durch den Versand bzw. Transport verursacht wurde, befreit den Käufer nicht von der Pflicht, den vereinbarten Kaufpreis zu zahlen.
8. Der Liefertermin gilt als ungefähre Angabe und ist nicht bindend; er kann sich verzögern, ohne dass eine Ersatz- oder Entschädigungspflicht für eventuelle direkte oder indirekte, vom Käufer infolge der verspäteten Lieferung erlittenen Schäden besteht und ohne dass dies zur Auflösung des Verkaufsvertrags aufgrund von Nichterfüllung des Verkäufers berechtigt.
9. Mit Ausnahme von Fällen höherer Gewalt, bei Streiks oder in allen anderen Fällen, durch die der Verkäufer vorübergehend außerstande ist, den Verkaufsvertrag ordnungsgemäß zu erfüllen, hat der Verkäufer das Recht, vom Vertrag zurückzutreten, ohne dass der Käufer berechtigt ist, eventuelle Schadensersatzansprüche zu stellen, mit Ausnahme der Rückzahlung einer allfälligen Anzahlung im Falle eines Rücktritts.
10. Die Zahlung des Verkaufspreises der Produkte hat direkt an den Sitz des Verkäufers zu erfolgen. Bei verspäteter Zahlung befindet sich der Käufer automatisch in Verzug und ist verpflichtet, Zinsen in dem von der Gesetzesverordnung 231/2002 über Zahlungsverzögerungen bei Handelsgeschäften festgelegten Umfang sowie mit den entsprechenden Fristen zu zahlen.
11. Der Verkäufer haftet nicht für eventuelle dem Käufer bekannte oder erkennbare Mängel, wenn dieser die Ware nicht umgehend zurückgewiesen hat. Beanstandungen oder Reklamationen in Bezug auf Produktmengen müssen jeweils bei Auslieferung gemeldet und auf den entsprechenden Transportunterlagen vermerkt werden. Der eventuelle Ersatz des Produkts ist dabei nicht gleichbedeutend mit einer Akzeptanz der Beanstandung oder Reklamation. Die entsprechende Gutschrift für den Verkäufer erfolgt erst nach Rückgabe der mangelhaften Produkte und unter der Voraussetzung, dass die Verantwortung des Käufers anerkannt oder anderweitig festgestellt wurde.
12. Die Zeichnungen, Modelle, Darstellungen und anderen technischen Informationen über die Produkte, die den Gegenstand des Verkaufs bilden, ebenso wie die Muster, Kataloge, Photos und ähnlichen Materialien bleiben immer geistiges Eigentum des Verkäufers und dürfen daher weder kopiert, noch anderen überlassen oder in irgendeiner anderen Form genutzt werden.
13. Die als Anzahlung zur Bestätigung entrichteten Beträge können vom Verkäufer bei Annullierung des Auftrags und/oder in jedem anderen Fall einer Nichterfüllung seitens des Käufers einbehalten werden, die den Rücktritt des Verkäufers rechtfertigt, vorbehaltlich des Rechts, die Erfüllung des Vertrags zu verlangen und ebenso vorbehaltlich des Rechts, die Entschädigung eines darüber hinausgehenden Schadens zu verlangen. Umgekehrt werden im Fall der Erfüllung der Vertragsverpflichtungen seitens des Käufers die von diesem als Anzahlung zur Bestätigung entrichteten Beträge auf den Kaufpreis angerechnet; diese Beträge gelten auf jeden Fall, ebenso wie alle anderen Vorauszahlungen, als unverzinslich.
14. Die eventuelle Hinnahme einer der Parteien von Verhaltensweisen der anderen Vertragspartei, durch die die Verkaufsbedingungen verletzt werden, stellt keinen Verzicht auf sich aus verletzten Klauseln ergebende Rechte dar, noch auf das Recht, die korrekte Erfüllung aller Fristen und Bedingungen zu verlangen, die vom Kaufvertrag vorgesehen sind.
15. Der Verkäufer behält das Eigentumsrecht an den gelieferten Produkten bis zur vollständigen Zahlung des jeweils in der Rechnung angegebenen Preises. Bis zu diesem Datum gelten die gelieferten Produkte nur als beim Verkäufer hinterlegt. Dieser letztere übernimmt daher auch das Risiko für Schäden, die an den hinterlegten Produkten aus irgendeinem Grund entstehen könnten.
16. Der Käufer wird aufgefordert, besondere Aufmerksamkeit darauf zu verwenden, dass nicht alle in dieser Preisliste angegebenen Produkte mit dem amerikanischen oder kanadischen Markt vereinbar sind. Daher ist der Käufer, falls er vorhat die genannten Produkte in die USA und/oder in irgendein Nicht-EU-Land zu exportieren, verpflichtet, sich jeweils vorher an die Handelsabteilung des Verkäufers zu wenden, um die Bestätigung zu erhalten, dass das betreffende Produkt allen technischen Erfordernissen und den gesetzlichen Vorschriften entspricht, die zum Schutz des Endverbrauchers in dem jeweiligen Bestimmungsmarkt vorgesehen sind. Der Verkäufer übernimmt dabei keine Verantwortung für vom Käufer ergriffene Initiativen, wenn er nicht vorher darüber in Kenntnis gesetzt worden ist und unabhängig von der eventuellen schriftlichen Genehmigung des Verkäufers zum Export und/oder zur Verwendung des Produkts in einem Nicht-EU-Land.
17. Der Käufer ist verpflichtet, seine Kunden und/oder Endverbraucher über die Eigenschaften des Produkts in Kenntnis zu setzen, um die Gefahr von deren missbräuchlichen Verwendung, die den Verkäufer möglichen Schadensansprüchen aussetzen könnte, auf ein Mindestmaß zu reduzieren. In Ermangelung dieser vorherigen Informationstätigkeit befreit der Käufer den Verkäufer ausdrücklich von jeder möglichen Verantwortung.
18. Die verkaufende Gesellschaft garantiert, dass die Produkte die in der Bestellbestätigung enthaltenen technischen Spezifikationen einhalten, unbeschadet der von der industriellen Fertigung als akzeptabel angesehenen Abweichungen.
19. Die verkaufende Gesellschaft garantiert nicht die Eignung der Produkte zu spezifischen oder Sonderzwecken oder besonderen Verwendungen, außer in dem Fall, wo eine entsprechende Anfrage seitens des Käufers ausdrücklich schriftlich vom der verkaufenden Gesellschaft bestätigt wurde, und dies auf der Bestellbestätigung erwähnt wird. Der Käufer muss sicherstellen, dass eventuell erforderliche spezifische Standards und/oder rechtliche Anforderungen in der entsprechenden Bestellbestätigung seitens der verkaufenden Gesellschaft ausdrücklich enthalten sind.
20. Die von der verkaufenden Gesellschaft gelieferten Informationen zur spezifischen Eignung von Produkten haben reinen Beispielwert.
21. Eventuell von der verkaufenden Gesellschaft geleistete Hilfs- und/oder Berechnungsdienste müssen als reine Orientierungshilfe und als unverbindlich bewertet werden, denn sie liefern eine bloße allgemeine Empfehlung zur Positionierung der Produkte und müssen jedenfalls vom Käufer vollständig geprüft werden; selbstverständlich übernimmt die verkaufende Gesellschaft, da es sich um bloße unverbindliche Empfehlungen handelt, keine Haftung für eventuell aus der inkorrekten oder ungewohnten Anwendung der Produkte entstehende Schäden und/oder Verluste.
22. Da die Anwendung der Produkte seitens des Käufers nicht im Kontrollbereich der verkaufenden Gesellschaft liegen, ist letztere für die tatsächliche Anwendung der Produkte nicht verantwortlich; die verkaufende Gesellschaft übernimmt keine Haftung für eventuell aus der inkorrekten oder ungewohnten Anwendung der Produkte entstehende Schäden und/oder Verluste.
23. Angesichts der Besonderheit von Snowsound-Fiber-Produkten, und obwohl die verkaufende Gesellschaft um die Einhaltung von hohen Qualitätsstandards bestrebt ist, sind bei einer Rollenhöhe von 150cm 3 Fehler alle 25 Meter und bei einer Rollenhöhe über 280 cm das Doppelte als annehmbar anzusehen. Die verkaufende Gesellschaft behält sich jedenfalls das Recht vor, für jeden festgestellten Fehler eine zur Kompensation der festgestellten Fehlerhaftigkeit geeignete Quantität an Material herabzusetzen. Die Rückgabe von zugeschnittenen Produkten und/oder Produktteilen wird nicht akzeptiert.
24. Der Widerruf einer Bestellung seitens des Käufers ist nur in Ausnahmefällen und nach schriftlicher Zustimmung der verkaufenden Gesellschaft zulässig.
25. Im Falle der Bestellung von vom Standard abweichenden Produkten und/oder Farben ist der Käufer dazu angehalten, die gesamte eigens dazu hergestellte Produktmenge anzukaufen.
26. Wenn nicht anders abgemacht und unbeschadet des Falls der vorsätzlichen Täuschung, beschränkt sich die Haftung der verkaufenden Gesellschaft für die verkauften Produkte auf einen sich auf das Dreifache des Bestellbestätigungswerts belaufenden Betrag, selbst im Falle der schweren Schuld.
27. Sämtliche Streitfragen, die sich im Zusammenhang mit dem Verkauf, sowie sämtlichen Änderungen, einschließlich derer in Bezug auf die Gültigkeit, Wirksamkeit, Auslegung, Durchführung und Auflösung des Vertrags ergeben können, unterliegen der ausschließlichen Zuständigkeit des Gerichtsstands von Mailand (Italien).
28. Auf jeden Fall müssen vor Kauf der Produkte jeweils die Verkaufsbedingungen, die technischen Eigenschaften sowie folgende weitere:

HINWEISE

berücksichtigt werden:

- Vor der Installation der Produkte muss die Tragfähigkeit der Wand/des Bodens/der Fläche überprüft werden, an der/auf dem die Produkte angebracht werden sollen, wobei kontrolliert werden muss, ob sie der Art der Benutzer/Verwendung entsprechen, für die sie vorgesehen sind.
- Die Produkte sind nicht für Kinder geeignet.
- Die Produkte sind nicht für die Verwendung im Außenbereich geeignet.
- Die an der Wand/am Boden/ der Fläche montierten Produkte sehen eine Installation mit Verankerungsvorrichtungen vor, die nicht in den Abbildungen des Katalogs gezeigt werden.
- Die Produkte dürfen ausschließlich durch technisches Fachpersonal montiert und/oder installiert werden, wobei jeweils entsprechend geeignete Geräte und Ausrüstung verwendet werden müssen.
- Vor der Montage und Installation der Produkte muss die den Produkten beiliegende Gebrauchsanweisung aufmerksam durchgelesen werden, wobei besonders die Hinweise und die entsprechenden erklärenden Zeichnungen beachtet werden müssen; sollte die Gebrauchsanweisung nicht beiliegen, wenden Sie sich bitte an die technische Abteilung des Verkäufers.
- Um die Produkte an Wand/Boden/Oberflächen zu befestigen, müssen geeignete Beschläge verwendet werden, die in der Lage sind, die auf diese Weise erzeugten Kräfte auszuhalten; auf jeden Fall müssen passende Halterungen verwendet werden, die jedes einzelne Element tragen können.
- Bei nicht vorschriftsmäßiger Installation und/oder im Fall der Überschreitung der in der vorliegenden Preisliste und/oder den jedem einzelnen Produkt beiliegenden Gebrauchsanweisungen angegebenen Höchstlasten könnten sich Gefahrensituationen ergeben, die Produkte könnten kollabieren, nachgeben, herunterfallen und Sach- und/oder Personenschäden verursachen: die angegebenen Lasten daher nie überschreiten.
- Bei Zweifeln in Bezug auf die Art der Installation und/oder die jeweilige Tragfähigkeit der Wand/des Bodens/der Fläche, an der/auf dem das Produkt angebracht werden soll ist, nicht mit der Installation beginnen.
- Halten Sie sich an die in der vorliegenden Preisliste enthaltenen Anweisungen und Zusammenstellungen halten; bei anderweitigen Zusammenstellungen und/oder für nähere Informationen über die Produkte und die Art ihrer Installation wenden Sie sich bitte an die technische Abteilung des Verkäufers.
- Leichte Farbunterschiede zwischen zwei Partien sind unter Wahrung der für Industrieproduktion als zulässig betrachteten Abweichungen als normal zu anzusehen.- Es ist ausschließlich der italienische Text verbindlich, die Übersetzungen dienen lediglich der vereinfachten Lesbarkeit.

Caimi Brevetti S.p.A. si riserva, a proprio insindacabile giudizio, la facoltà di modificare senza preavviso i materiali costruttivi, le caratteristiche tecniche ed estetiche, nonché le dimensioni degli elementi illustrati nel presente listino le cui immagini e colori sono puramente indicativi.

Caimi Brevetti S.p.A. reserves, by its unappealable judgment, the right to modify without prior notice the building materials, the technical and aesthetic specifications, as well as the dimensions of the products in this price list, where pictures and Colors are purely as an indication.

Caimi Brevetti S.p.A. se réserve, à son jugement sans appel, la faculté de modifier sans aucun préavis les matériaux de construction, les caractéristiques techniques et esthétiques ainsi que les dimensions des éléments illustrés dans ce tarif, dont les images et couleurs sont seulement indicatifs.

Caimi Brevetti S.p.A. se reserva, a su indiscutible juicio, el derecho a modificar sin previo aviso los materiales de construcción, las características técnicas y estéticas, así como las medidas de los productos del presente lista de precios, donde las imágenes y los colores son meramente indicativos.

Caimi Brevetti S.p.A. behält sich das Recht vor, ihrer unkontrollierbaren Meinung nach, verwendete Materialien, technische und ästhetische Änderungen sowie die Abmessungen der in diesem Preisliste abgebildeten Produkte ohne vorherige Ankündigung zu ändern. Die gezeigten Fotos und deren Farben dienen ausschliesslich zur ungefähren Information.



www.caimi.com